



Instruction Manual OH-200



UL325
compliant

UL991
compliant

Copyright © 2005 all-o-matic inc.

WWW.ALLOMATIC.NET

TABLE OF CONTENTS

Important safety instructions.....	2
Different UL 325 class types.....	3&4
Overhead dimensions.....	5
Operator installation.....	6
Mounting instructions.....	7
Gate travel adjustment.....	8
Opening wiring directions.....	9
Electrical power connection.....	10
Typical loop layout.....	11&12
Accessory connections.....	13
Multiple safety device connection.....	14
Leading edge installation.....	15
Three button station system installation.....	16
Radio receiver hookup.....	17
Open and close electronic reversing sensor(ERDs) adjustment....	18
Timer adjustment.....	19
Dip switch functions.....	20
Emergency release.....	21

IMPORTANT SAFETY INSTRUCTIONS

WARNING

To reduce the risk of **injury**:

READ THE FOLLOWING DIRECTIONS. DO NOT EVEN THINK OF STARTING UNTIL YOU HAVE READ AND UNDERSTAND THESE DIRECTIONS. IF THERE IS SOMETHING YOU DO NOT UNDERSTAND CALL US.

Never let children operate or play with gate controls. Keep the remote control away from children.

Always keep people and objects away from the gate. No one should cross the path of the moving gate.

This operator must be tested monthly. The gate must reverse on contact with a ridged object or stop when an object activates the non-contact sensors. After adjusting the force or the limit travel, retest the gate operator. Failure to adjust and retest the gate operator properly can increase the risk of injury.

Keep gates properly maintained. Have a qualified service person make repairs to gate hardware. It takes many years of experience to make proper adjustments to gate hardware or operators.

There is nothing on a gate operator that is easily repaired without a great deal of experience. Save yourself some time and call a qualified Gate Service Contractor who knows your type of gate operator.

INSTALL THE GATE OPERATOR ONLY WHEN YOU HAVE READ THE FOLLOWING:

- *Confirm that the gate operator being installed is appropriate for the application.
- *Confirm that the gate is designed and built according to current published industry standards.
- *Confirm that all appropriate safety features and safety accessory devices are being incorporated, including both primary and secondary entrapment protection devices.
- *Make sure that the gate works freely before installing the operator.
- *Repair or service worn or damaged gate hardware before installation of the operator.
- *Eliminate all gaps in a sliding gate below a 4 foot height that permits a 2 ¼ inch sphere to pass through any location, including the area of the adjacent fence covered when the gate is in the open position.
- *Eliminate all gaps in a swinging gate below a 4 foot height that permit a 4 inch sphere to pass through any location, including the hinge area of the gate.
- *Operator must be disconnected from the power source before attempting any installation of accessories.
- *Install this gate operator according to our installation instructions.
- *Adjust the operator clutch or load sensing device to the minimum force setting that will still allow for reliable gate operation.
- *Install the operator inside the fence line(do not install the operator on the public side of fence line).
- *Install a proper electrical ground to a gate operator.
- *Install controls where users cannot touch or reach through the gate to operate the controls.
- *Install all warning signs and take pictures of the installation.
- *Test all safety features for proper function before placing the automatic vehicular gate into service.
- *Train owner/users about basic functions and safety features of the gate system, including how to turn off the power and how to operate the manual disconnect feature.
- *Leave safety instructions, product literature, installation manual and maintenance manual with end user.
- *Explain to the owner/user the importance of routine service and retesting on a monthly basis.

DIFFERENT UL 325 CLASS TYPES

Class one: Residential

A vehicle gate operator intended for use at a home of one to four single family dwellings, garages or parking area.

Class Two: Commercial or General Public Access

A vehicular gate operator intended for use at a commercial location or building such as a multi-family housing unit (five or more single family units), hotel, garages, retail stores, other buildings servicing the general public.

Class three: Industrial or limited Access

A vehicular gate operator intended for use at an industrial location or building such as a factory, loading dock area, or other locations not intended to service the general public.

Class Four: Restricted Access

A vehicular gate operator intended for use at a guarded industrial location or building such as airport security areas or other restricted access locations not servicing the general public where unauthorized access is prevented via supervision by security personnel.

Other components required to satisfy UL 325

Each class must have a primary and secondary means to sense and react to obstructions within two seconds.

The six types of obstruction sensing systems are:

Type A:

Inherent obstruction sensing system. This system must sense and initiate the reverse of the gate within two seconds of contact with a solid object.

Type B 1:

Provision for connection of a non-contact device can be used, such as a secondary protection.

Type B2:

Provision for connection of a contact sensor. Examples include an edge device or equivalent. This can be used for secondary protection.

Type C:

Inherent adjustable clutch or pressure relief valve.

Type D:

Provision for connection of or provided with and actuation device requiring continuous pressure.

Type E:

Inherent audio alarm.

All of All-O-Matic Inc's Gate operators conform to the most ridged Class One.

OVERHEAD DIMENSIONS

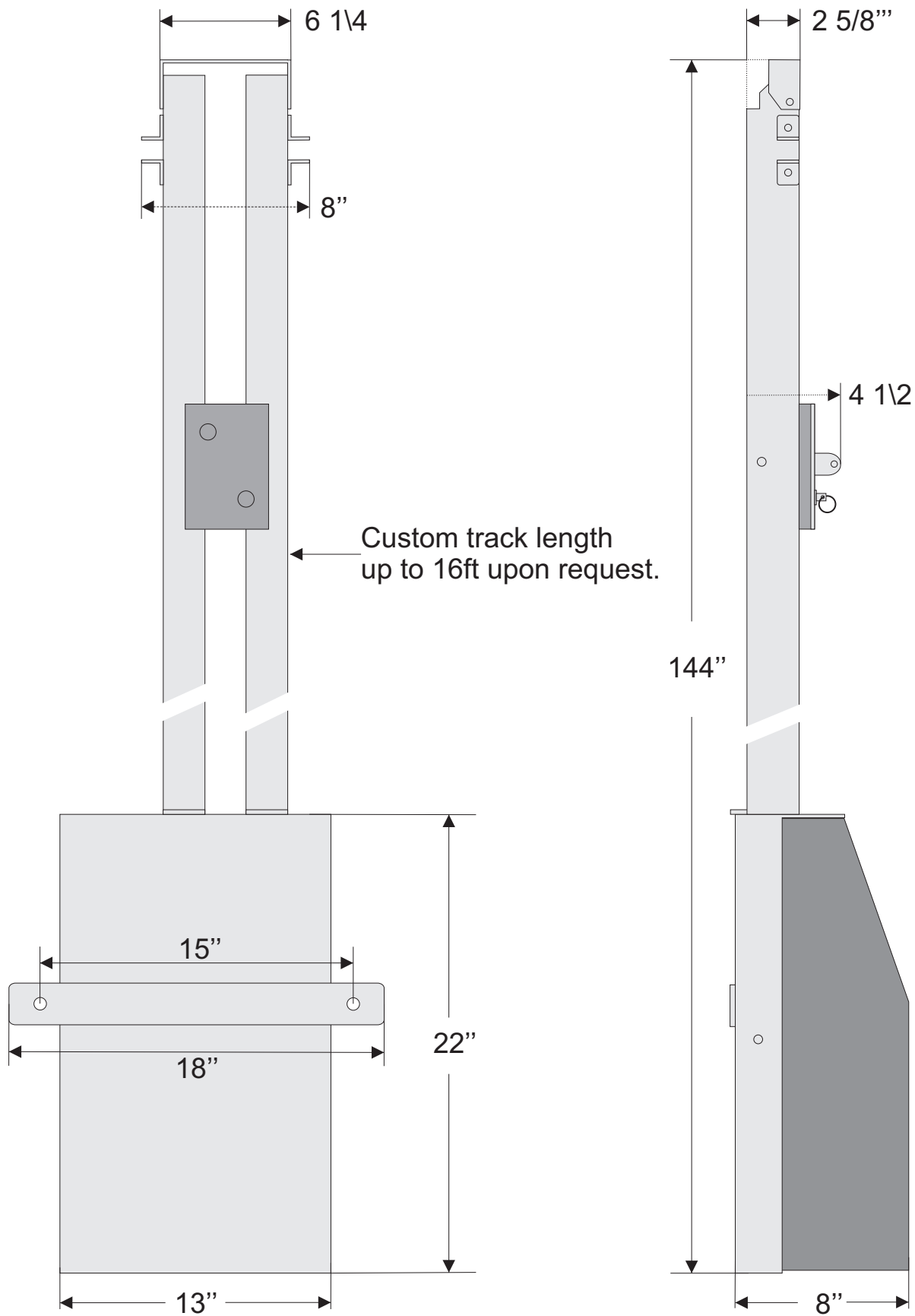

OPERATOR INSTALLATION

Note: Make sure the gate hardware is well balanced and the gate opens and closes smoothly.

With gate closed, mark the center of the gate.

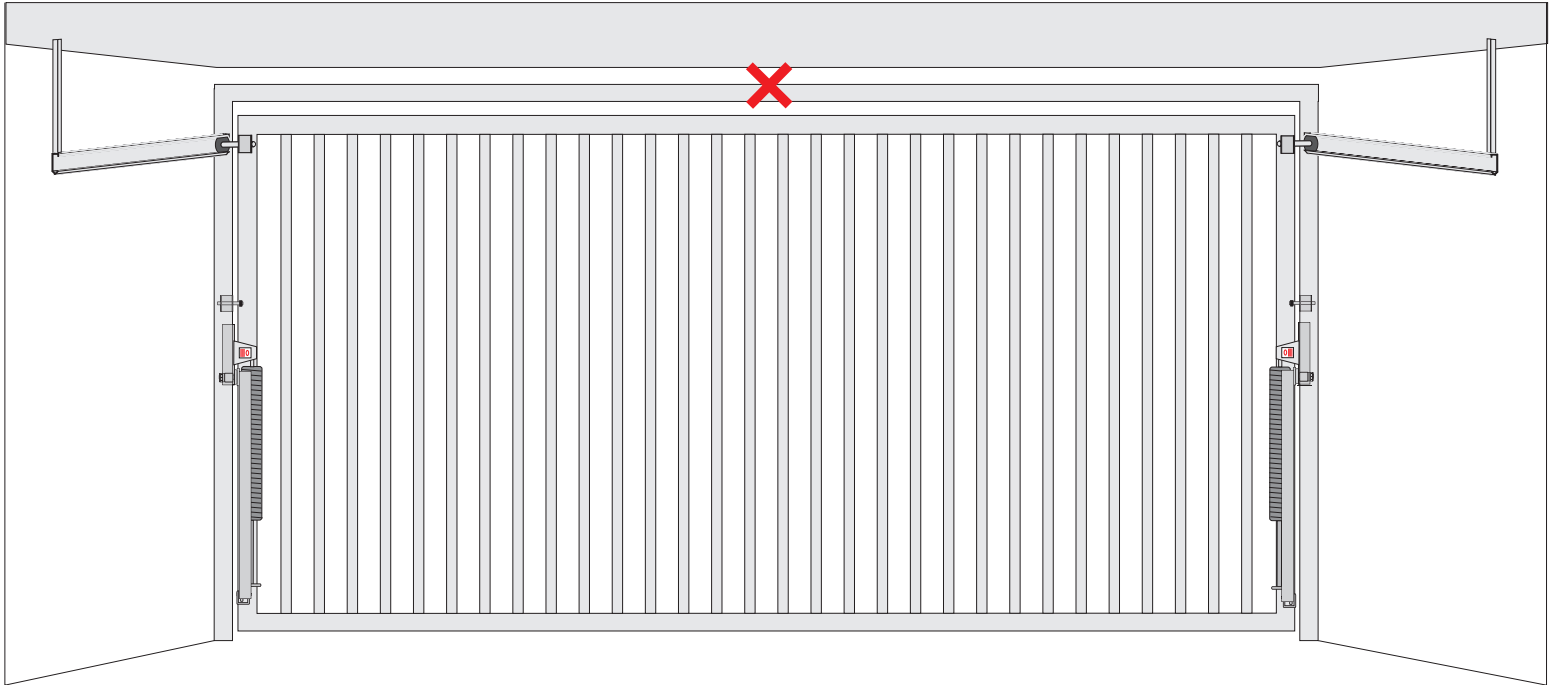

Lift gate to open position and mark the center point of the gate for the operator on the ceiling.

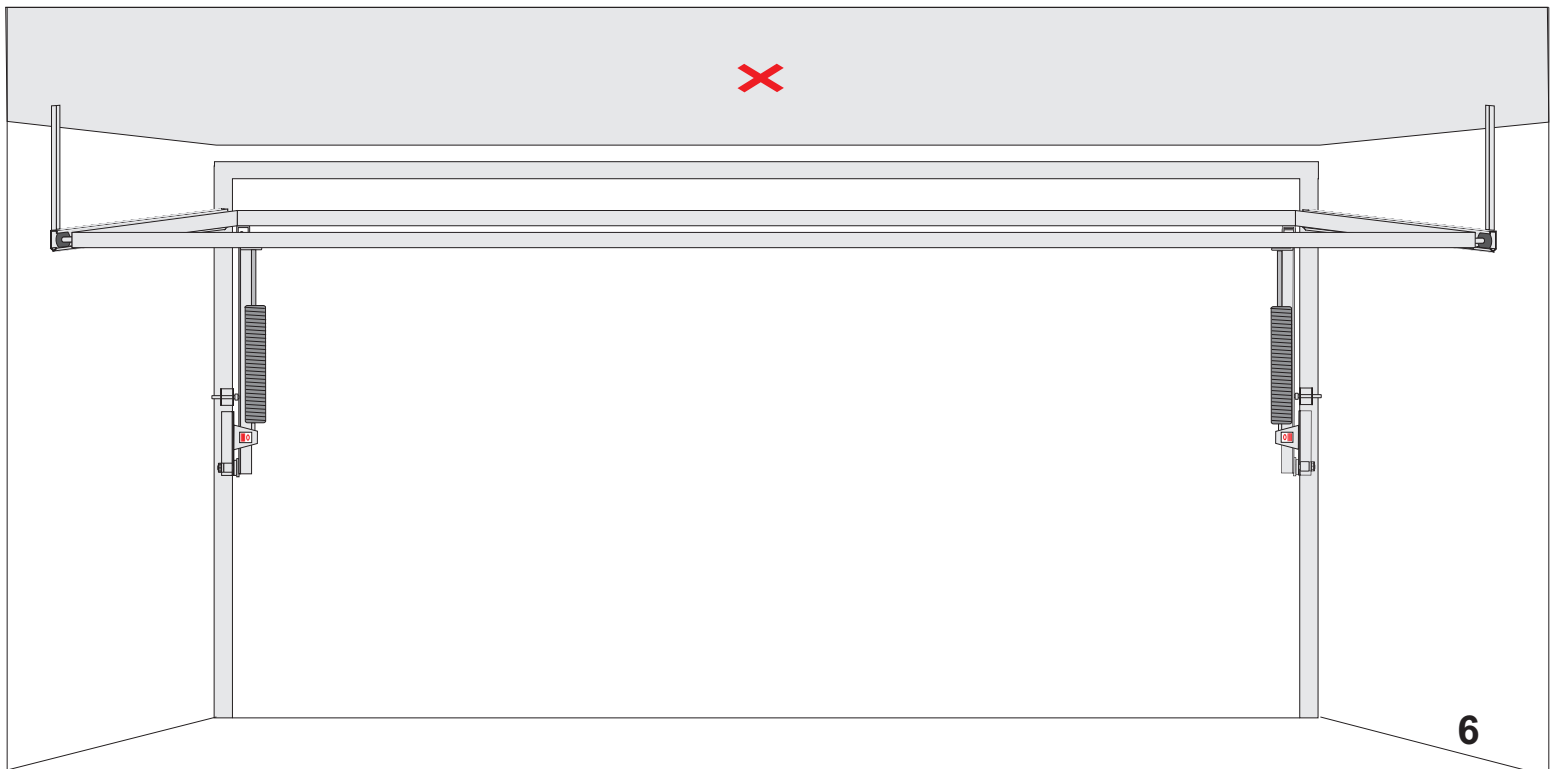

MOUNTING THE OPERATOR

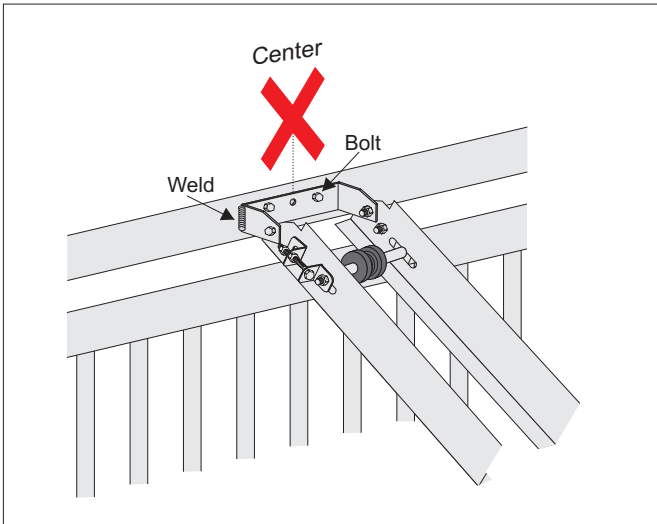

Make sure end bracket is in the center of the opening. Bolt or weld the end bracket to wall. The operator bracket must be at least 2.5" above the gate.

Level and align gate operator tracks before mounting it to the ceiling. Manufacture ceiling brackets to weld or bolt the operator in place.

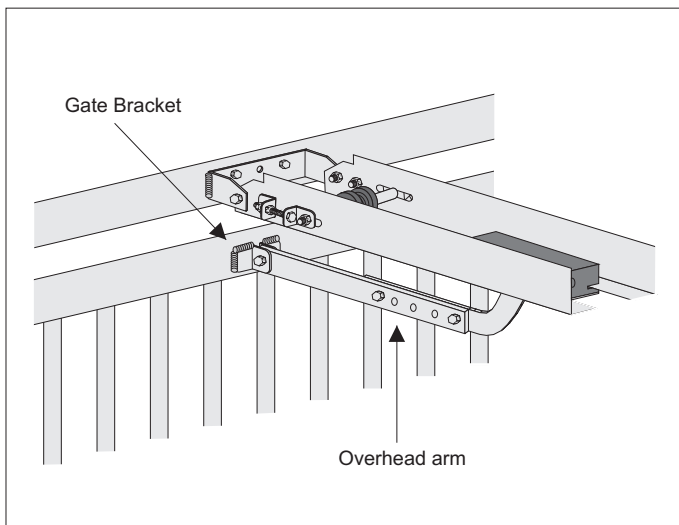
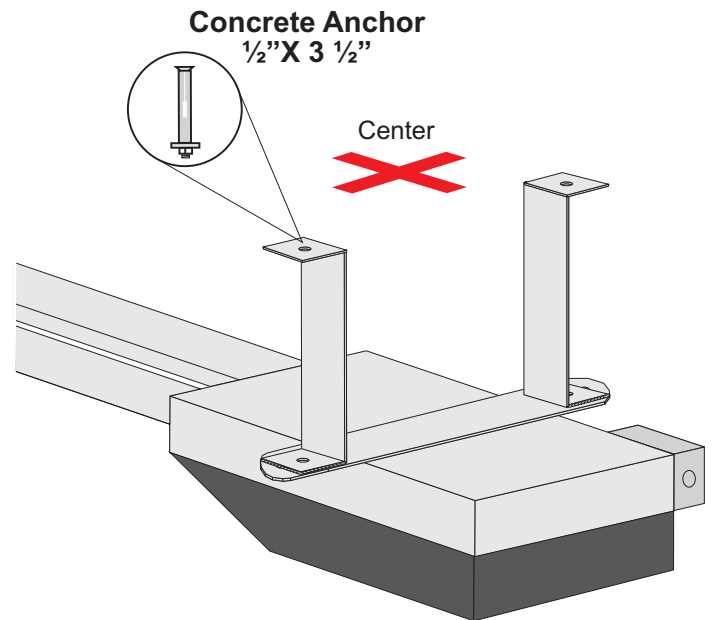

Weld gate bracket into place with overhead arm connected to insure alignment.

GATE TRAVEL ADJUSTMENT

Locate limit switches

- Step 1: Stop the gate operator using the three button station on the board.
- Step 2: Push limit lock plate down. Turn limit nut in the desired direction.
- Step 3: Place limit plate to its locked position.
- Step 4: Run gate operator.
- Step 5: If more adjusting is needed, repeat steps 1-4.

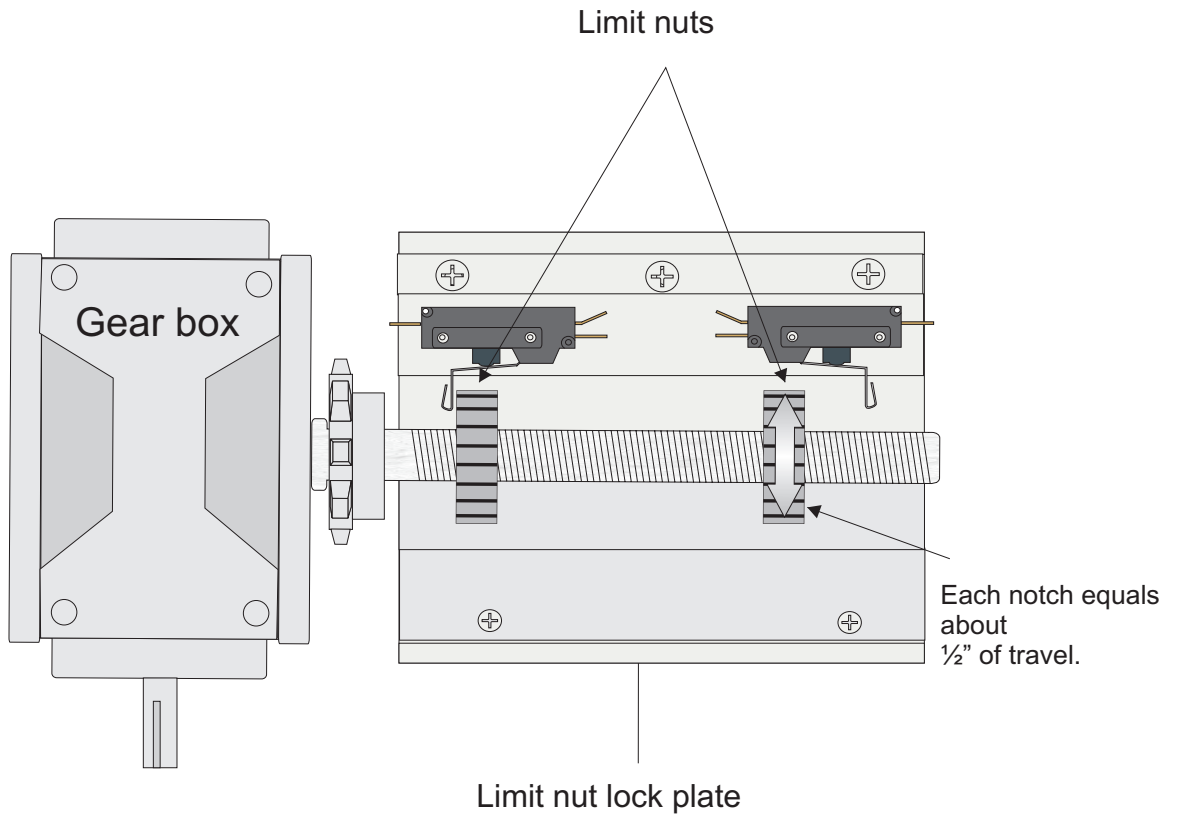

OPENING DIRECTION WIREING

Do not change wiring directions on overhead operator there already set.

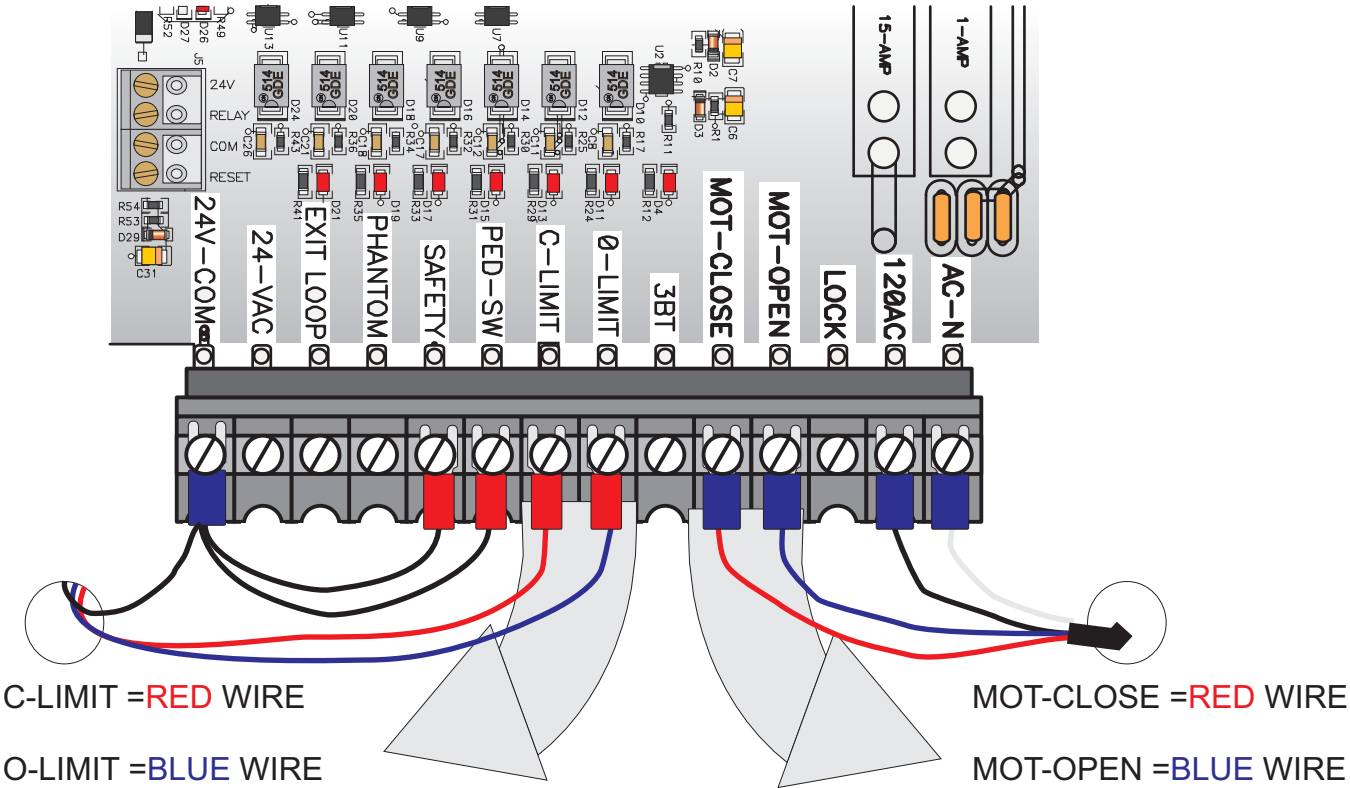

ELECTRICAL CONNECTION

OPERATORS MUST BE PROPERLY GROUNDED!

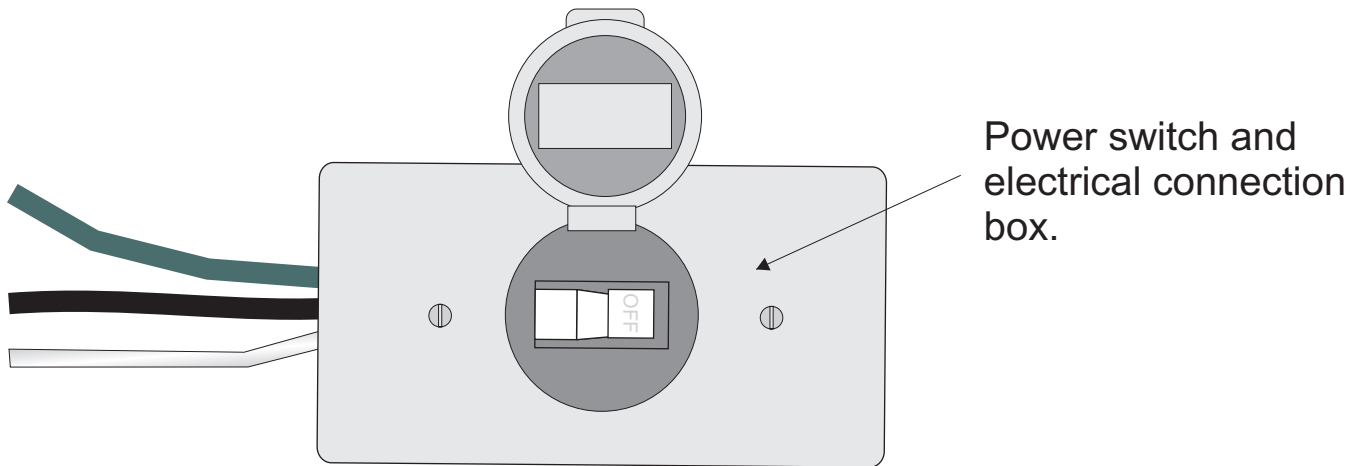

For power wires enclosure use UL listed conduits.

For power, a minimum of a 20-Amp dedicated circuit breaker is needed.

Connect black wire to 115 volts AC = Hot.

Connect white wire to AC = Neutral.

Connect ground wire to operator metal frame. Use a proper **ground rod** for a ground reference.

Use the shortest and thickest wire possible for ground.

All gate operators **MUST** be properly grounded.

A proper ground in a gate operator installation minimizes or prevents damage from an electrical charge, such as a near lightning strike or an electrical static discharge.

Use a single wire for the ground. **DO NOT** splice two wires for the ground. If the wire breaks or is cut, replace it with a single length. **NEVER** use two wires for the ground.

Check with your City code for proper earth ground rod type and proper grounding procedures.

TYPICAL LOOP LAYOUT

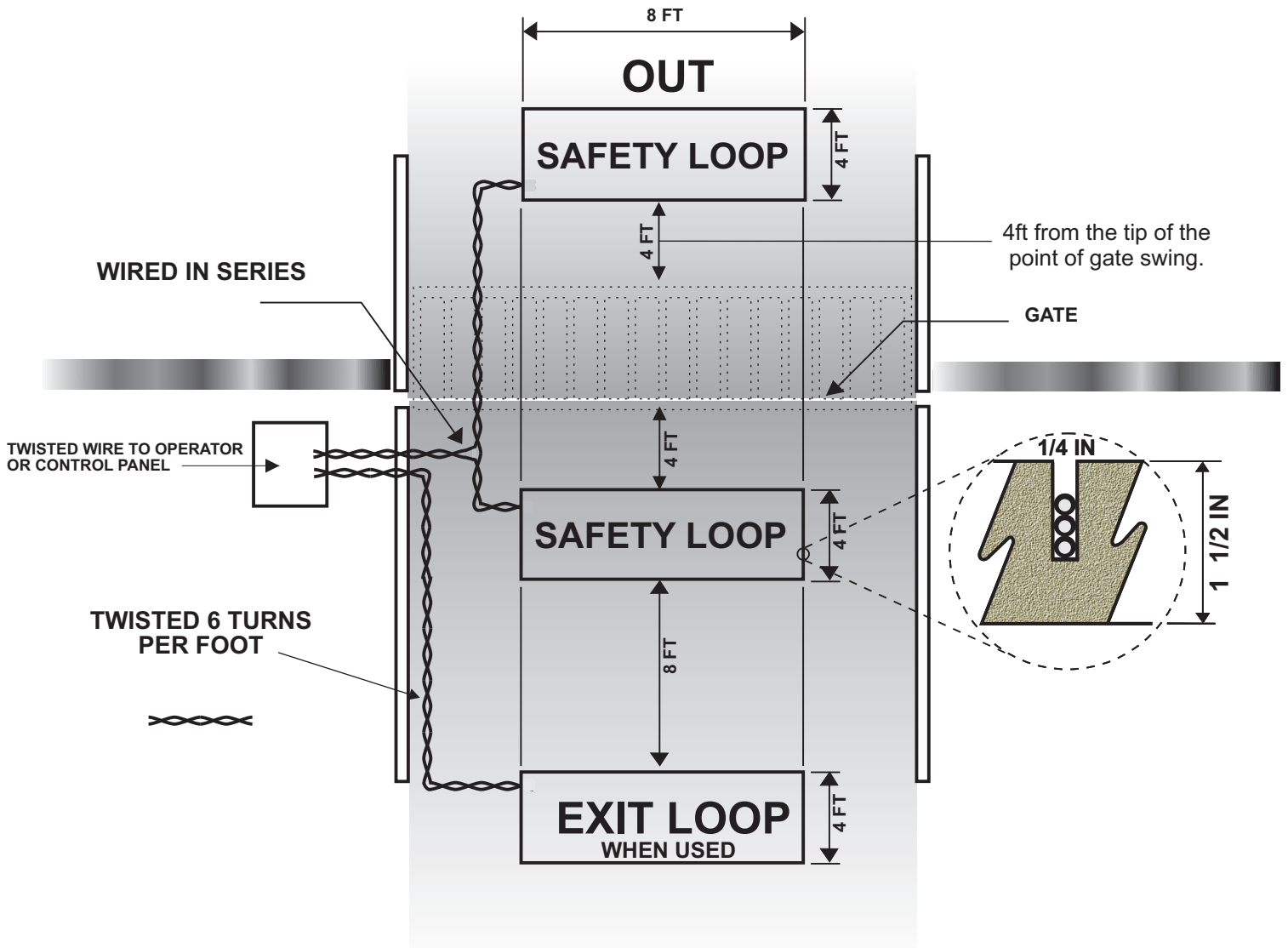

This is a normal loop layout. Remember when connecting to an All-O-Matic circuit board you use the **normally closed contacts** for your safety loop detector and **normally open contacts** from the exit loop. You must twist your wires from your exit point of the saw cut all the way to the circuit board, no exceptions.

GENERAL LOOP INSTALLATION GUIDELINES

The following loop installation guidelines are for installing typical driveway loops for access control applications (i.e. parking gates, sliding gates, swing gates etc...) Always consult with loop detector manufacturers for specific equipment guidelines. This will confirm that the proper configuration and installation techniques are properly applied for your application.

Useful information about inductive loops:

- A. The typical sensing height is 2/3 of the shortest leg of loop (in feet)
Therefore a 4' x 8' loop typically has a detection height of 2.6'.
- B. The inductance of a conventional four-side loop can be estimated using the formula:

$$L = P \times (T^2 + T) / 4$$

Where L = Loop Inductance in microHenries
P = Loop Perimeter in feet
T = Number of turns of wire in saw slot

Therefore a 4' x 8' loop with 3 turns would be:

$$L = (4 + 8 + 4 + 8) \times (3^2 + 3) / 4$$

$$L = 24 \times (9 + 3) / 4$$

$$L = 24 \times 12 / 4$$

$$L = 24 \times 3$$

$$L = 72 \text{ microHenries}$$

Suggested guidelines for loop installation:

Loop wires should be twisted 6 turns per foot, and twisted from saw slot to the detector. If possible start twisting the wires from the edge of the loop.

All 90 degree corners should be chamfered so that the course of the wire does not change direction sharply but rather at shallower angles of 45 degrees or less. Core drilling of the corners achieves the same effect but can still lead to failure due to sharp edges remaining in the corner area.

Loop Perimeter	# of Turns
6' - 12'	6
13' - 20'	5
21' - 60'	4
61' - 240"	3
241' & Up	2

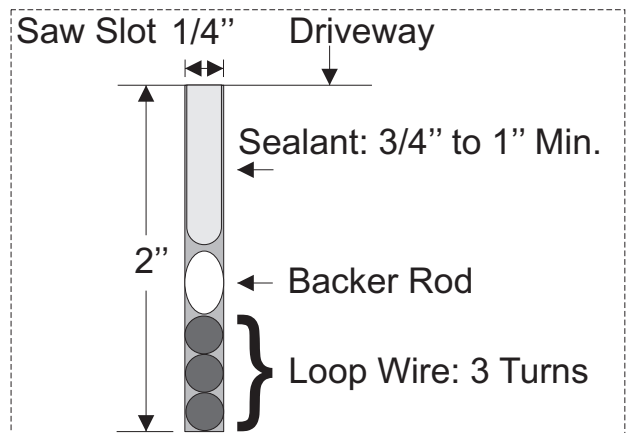
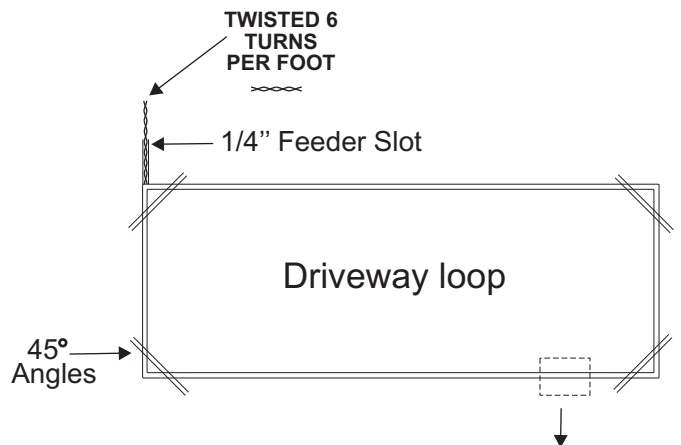

ACCESSORY CONNECTIONS

The circuit board **24-VAC** output provides up to 700 mAmps of power for accessories. More than two or three accessories will require a separate power supply.

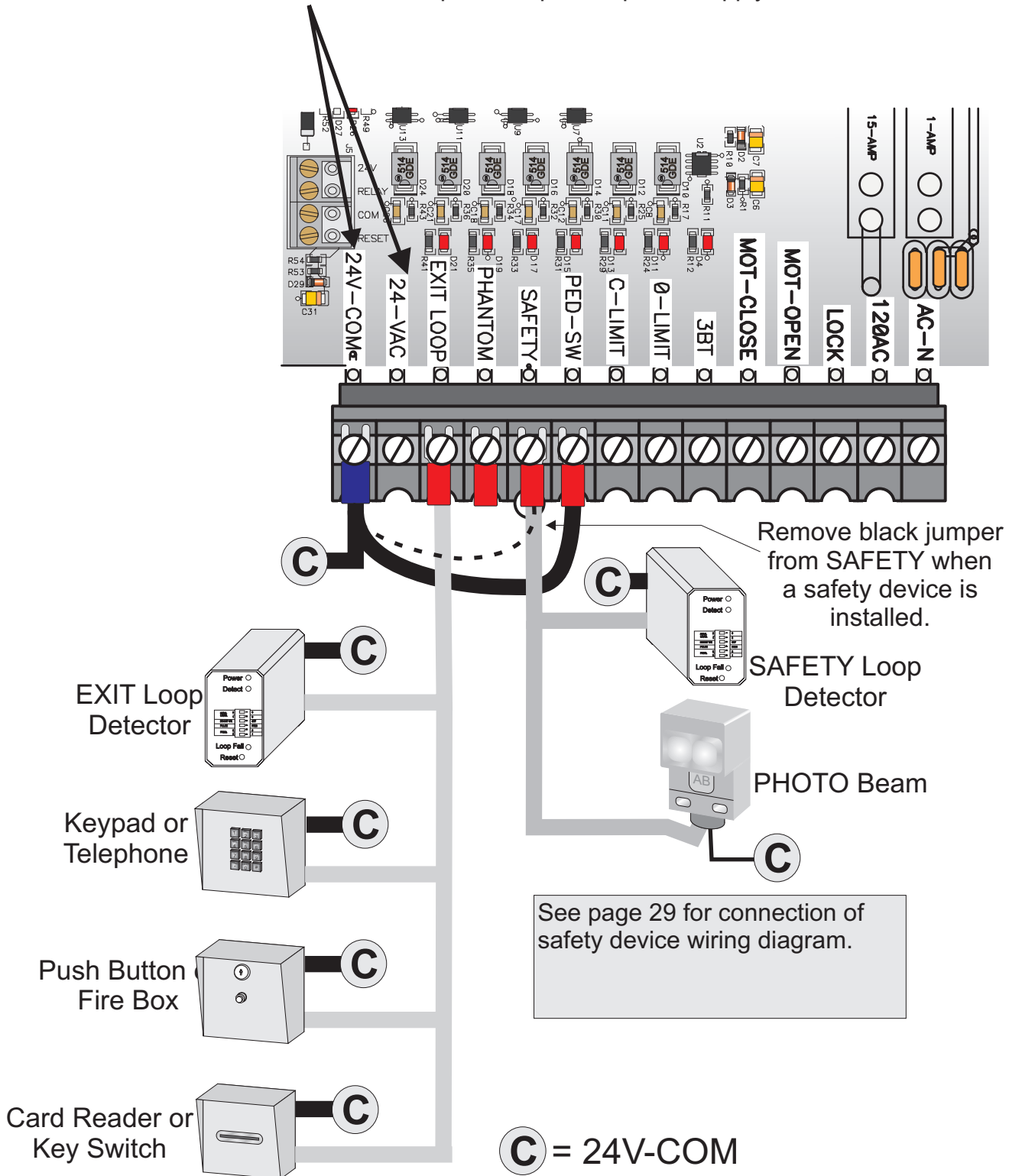

MULTIPLE SAFETY DEVICES CONNECTIONS

Multiple **SAFETY** devices installed together must be connected “in series”. Locate the normally closed (N.C.) dry contact from each accessory relay. Also, before installing the accessory devices, remove the black wire jumper from the **SAFETY** terminal position on the terminal strip of the control board.

Safety wire connections

From Accessory #1 to Terminal Strip	From Accessory #2 to Terminal Strip
Relay Com to 24V-COM	Relay N.C. to SAFETY

From Accessory #1 to Accessory #2
Relay N.C. To Relay Com

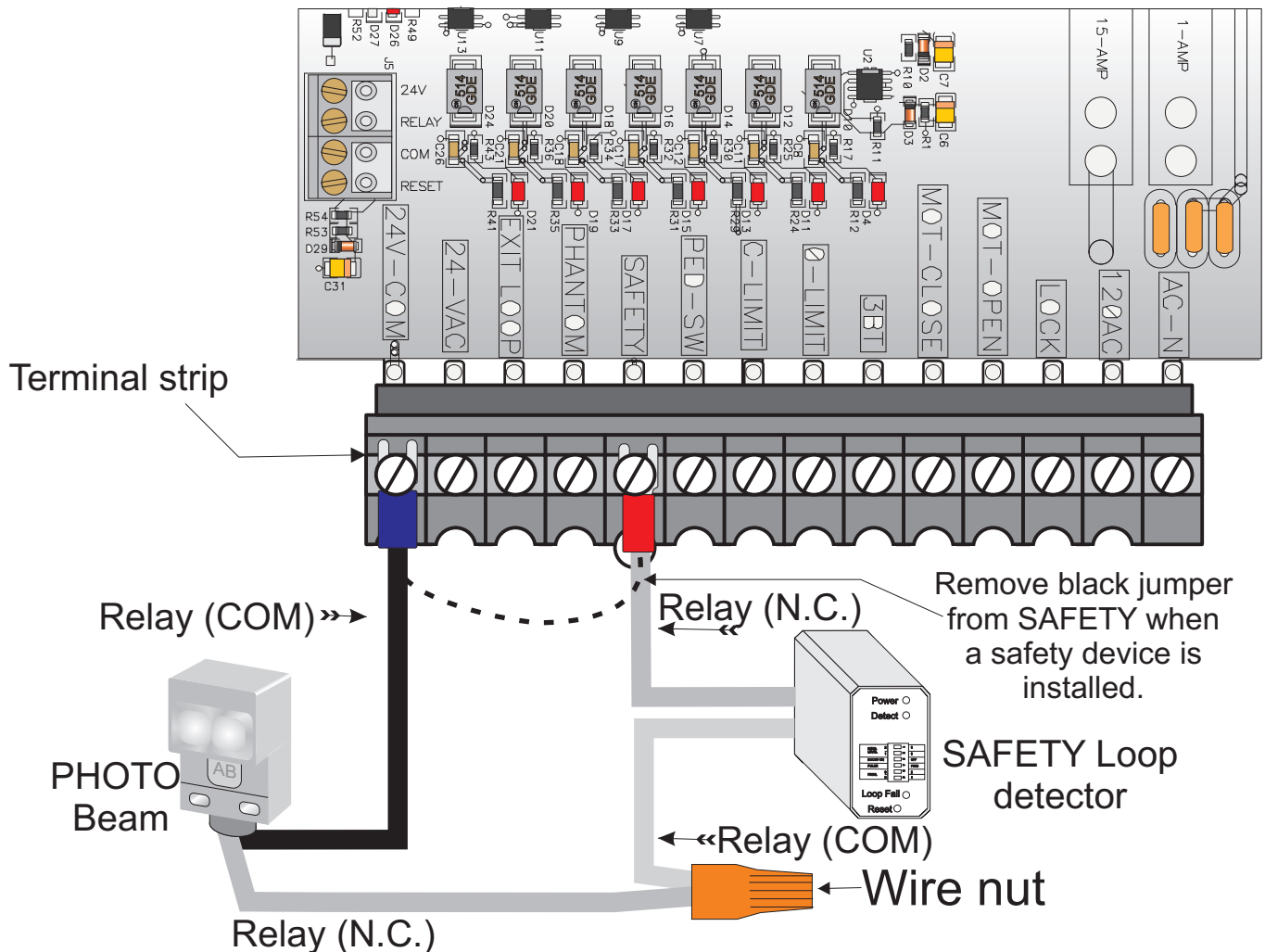

This diagram is for the relay wires of the safety devices, two wires to the terminal strip (one from each device) and two wires to the orange wire nut.

LEADING EDGE CONNECTION

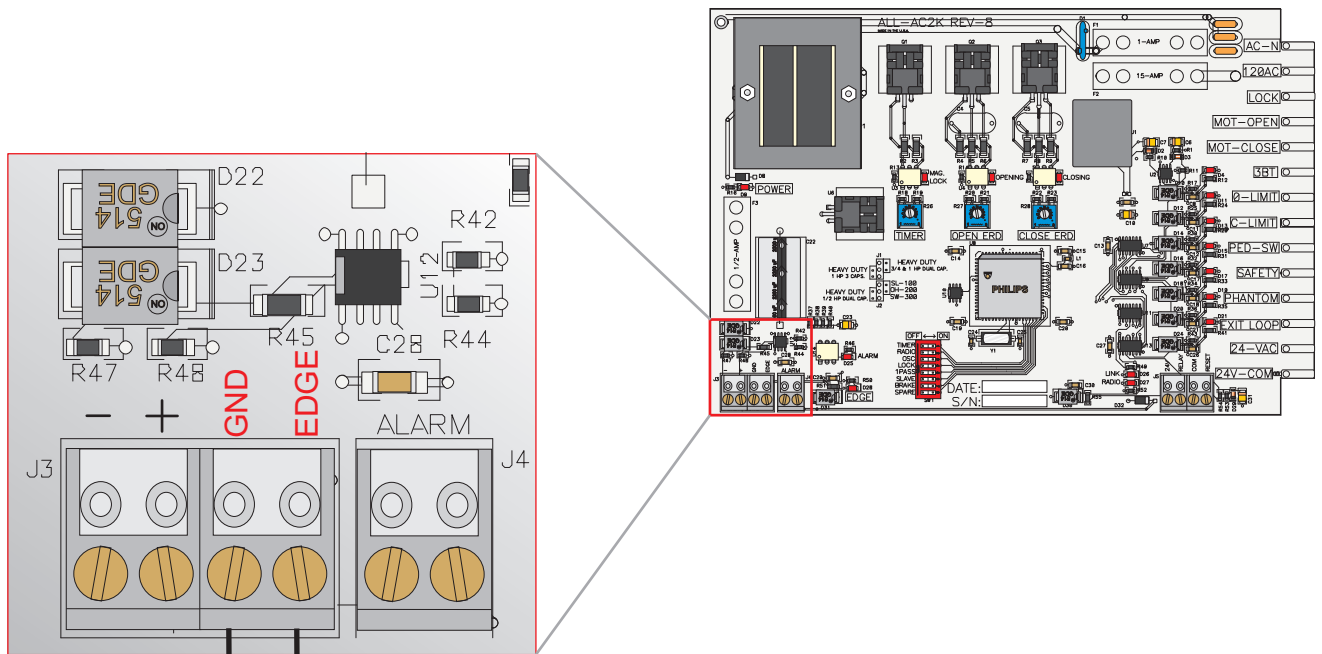

Connect one of the wires from leading edge to **GND** connector on control board.

Connect the other wire from leading edge to **EDGE** connector on control board.

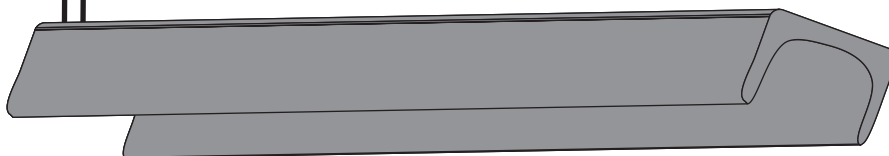

LEADING EDGE SENSOR

THREE BUTTON STATION SYSTEM

See push button connections below.

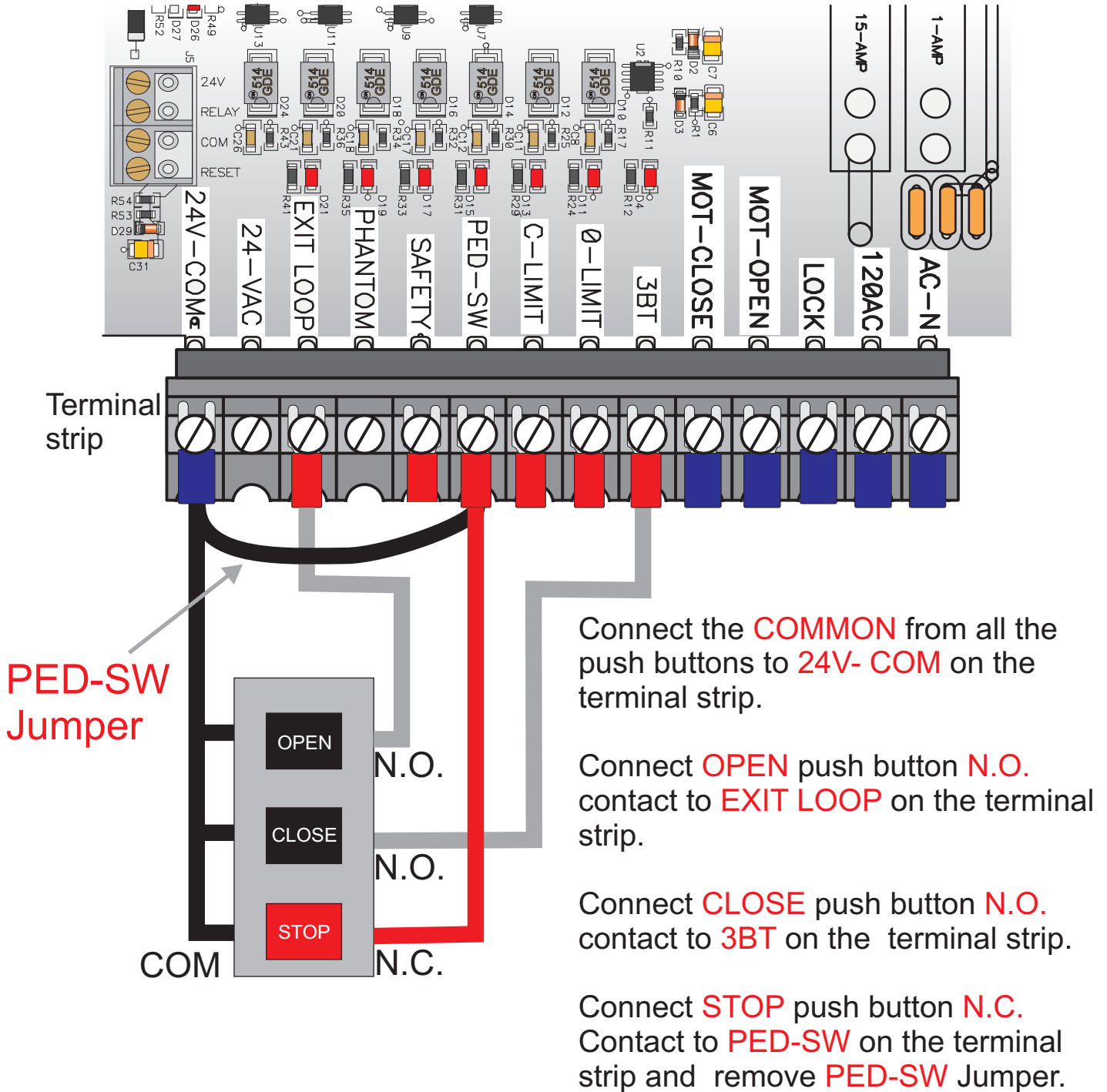

Connect the **COMMON** from all the push buttons to **24V- COM** on the terminal strip.

Connect **OPEN** push button **N.O.** contact to **EXIT LOOP** on the terminal strip.

Connect **CLOSE** push button **N.O.** contact to **3BT** on the terminal strip.

Connect **STOP** push button **N.C.** Contact to **PED-SW** on the terminal strip and remove **PED-SW Jumper**.

RADIO RECEIVER CONNECTIONS

3 wire receiver mounts on receiver strip outside control box as shown below.

4 wire receiver :connect the two grey wires to 1 & 2 terminals on receiver strip outside control box. Connect black wire to 24 V-COM and red wire to 24VAC on main control board terminal strip as shown below.

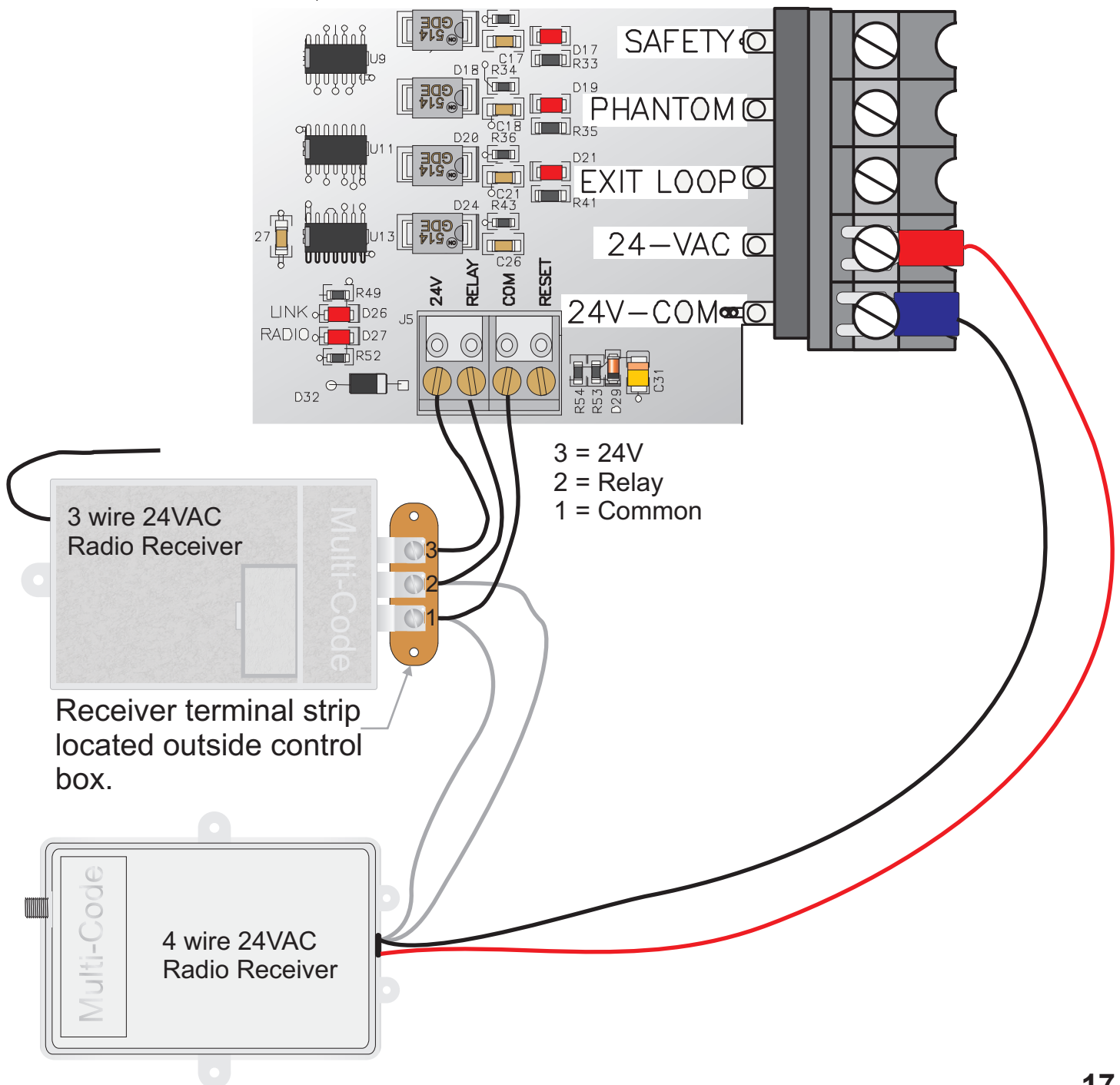

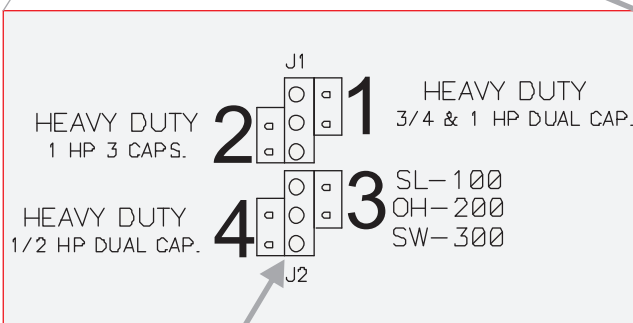
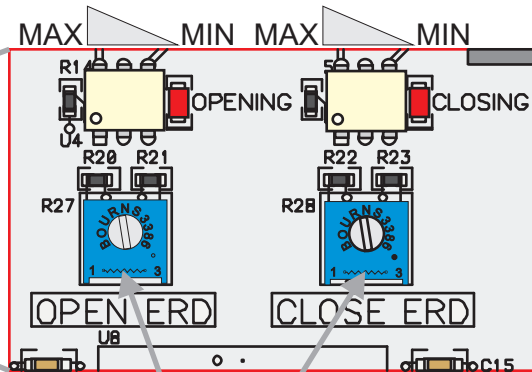
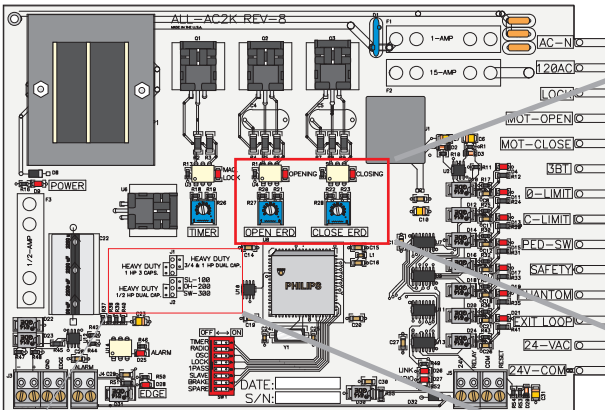

OPEN AND CLOSE ELECTRONIC REVERSING SENSOR(ERDs) ADJUSTMENT

Open and Close ERD SENSITIVITY



Set these pins for different motors using the chart below

 Counter clockwise maximum sensitivity
 Clockwise minimum sensitivity

When gate stops and reverses by itself, the ERD is **too sensitive**.

The gate must stop and reverse when it hits an obstruction or the ERD is **not sensitive enough**.

Motor Rating chart			
Model	HP Rating	# of Caps	Pin #
SL-100	1/2	1	3
SW-300	1/2	1	3
OH-200	1/2	1	3
SL-150	1/2	2	4
SL-150	3/4 & 1	2	1
SL-150	1	3	2
SW-350	1/2	1	3
SW-350	3/4 & 1	2	1

ERD'S must be adjusted by qualified technician.

The gate operator ERDs must be adjusted so that the gate provides regular, reliable and safe cycles.

ERD must be checked every six months.

TIMER ADJUSTMENT

TIMER ON: Timer to close, can be set from 1 to 60 seconds.

TIMER OFF: Gate operation is push button to open, push button to close.

TO OVERRIDE THE TIMER: Turn the RADIO switch to the "ON" position. This will allow the radio receiver to close the gate before the timer.

TIMER adjustment

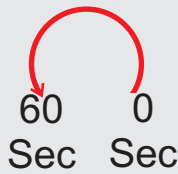

Turn potentiometer counter clockwise for more time.



Turn potentiometer counter clockwise for less time.

TIMER "ON" to activate the timer

RADIO "ON" = Allows the transmitter to close the gate before the timer.

Timer Pot
60 Sec. 1 Sec.

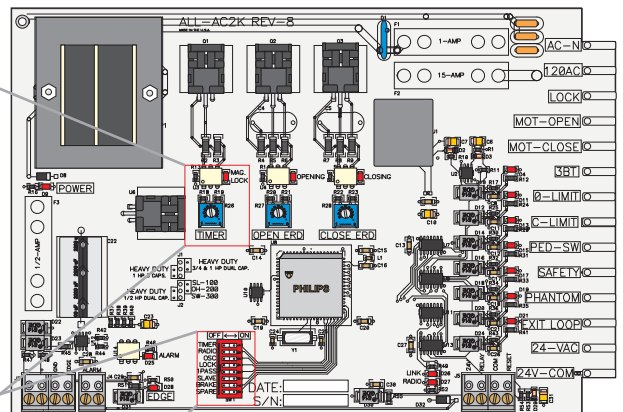
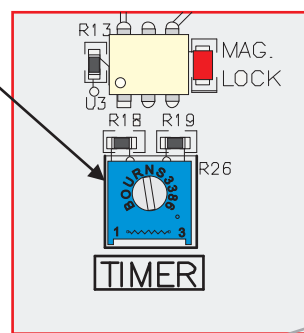

OFF ← → ON

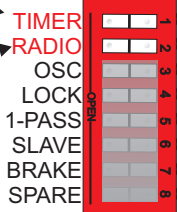

DIP SWITCH FUNCTIONS

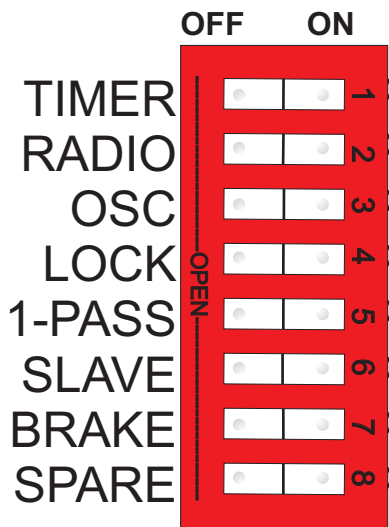

TIMER

TIMER switch “ON” activates the TIMER. See page 47 for details.

RADIO

RADIO switch “ON” allows the radio receiver to override the timer. See page 47 for details.

OSC

OSC switch “ON” allows the radio receiver to stop and reverse the gate in any direction. During a cycle the first signal stops gate, a second signal reverses gate.

LOCK

This function is to change from solenoid position in the “OFF” position, to magnetic lock in the “ON” position. The terminal position marked “LOCK” on the circuit board provides 115 volts for the each type of locks. Use appropriate step down transformer for specific locks. Refer to page 41 for lock connections and settings.

1-PASS

This is a true one pass, anti-tailgating feature. This feature may only be used with safety loops. With this switch in the “ON” position, the gate will open until one car passes the safety loops then it will stop and close. If a second car pulls on the loop the gate will stop the car must then back off the loop before the gate will close.

SLAVE

This feature is used on master/slave setups. Set slave switch “ON” on slave machine, all other switches “OFF”. Set slave switch to the “OFF” position on master machine. Set other function switches on master machine as desired. See page 20 for more details on master/slave connections and settings.

BRAKE

The BRAKE helps the gate to stop at the precise moment of contact of the limit nuts with the limit switches. This function should only be used when an uphill or downhill installation is required. Replace the 15 Amps fuse with a 20 Amps fuse when this function is used.

SPARE NOT USED

EMERGENCY RELEASE

To manually release pull locking latch to the side and pull release ring downward with a slit pull backward to disengage from lock pin.

Make sure gate is in full open position to avoid gate from coming down if not well balanced .

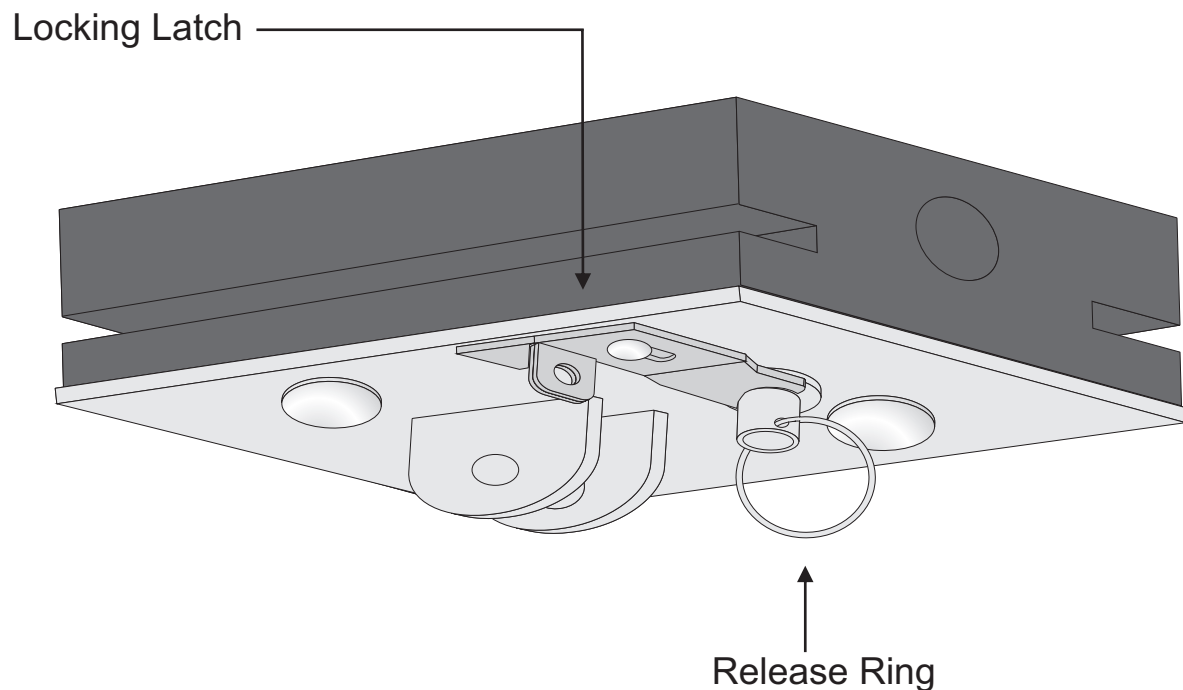

NOTE: To avoid serious injury disengage gate only when in the close position or gate is clear of persons and obstructions.

ALL-O-MATIC'S good service and high quality by years of, proven reliability place the ALL-O-MATIC slide gate operators ahead of the competition. The SL-150 is our highest duty rated operator and the most powerful continuous duty operator available in the market today. The SL-150 has a foot pedal release in the event of a power failure.

The SL-100 is our most popular gate operator. It is continuous duty for commercial and residential use. In the event of power failure, the gate can be pushed open. A battery back up is also available on the SL-100.

El buen servicio, la alta calidad y los años de la confiabilidad probada de ALL-O-MATIC, colocan a los operadores corredizos, delante de la competencia. El SL-150 es nuestro operador con la capacidad más alta y el operador más potente de uso continuo disponible en el mercado hoy. El SL-150 cuenta con un pedal de pie para liberación del portón en el acontecimiento de un apagón. El SL-100 es nuestro operador más popular. Está clasificado para uso continuo comercial y residencial. En el evento de un apagón, puede abrir el portón empujandolo. Un respaldo de batería esta tambien disponible en el SL-100.

ALL-O-MATIC INC
Northridge, CA 91324

WWW.ALLOMATIC.NET