

# ALL-O-MATIC®



Intertek

UL-325 **6th edition**,  
UL-991 & CSA C22.2  
#247 Compliant

## SW-300DC, SW-325DC & SW-350DC Installation Manual



# TABLE OF CONTENTS

Important safety instructions.....	2&3
Different UL 325 class types.....	4
Concrete pad Specs.....	5, 6, 7 & 8
Operator & Arm Layout.....	9, 10 & 11
Compact Installation.....	12
Torque limiter & Arm adjustment for SW-300DC & SW-350DC.....	13
Torque limiter & Emergency release for SW-325DC.....	14
Gate travel adjustment.....	15
Directional settings.....	16
Electrical power connections.....	17
Typical loop layout.....	18
General loop installation guidelines.....	19
Accessory connections.....	20
Plug-in detector inatallation.....	21
Entrapment protection installation.....	22
Entrapment protection device connection.....	23
Three button station.....	24
Magnetic/Solenoid lock installation.....	25
Master/Slave connections.....	26
Radio receiver hookup.....	27
Inherent entrapment protection system (ERD) adjustment.....	28
Timer adjustment.....	29
Programable relay & leaf delay.....	30
Variable speed adjustment.....	31
Dip switch functions.....	32
Emergency release for SW-350DC.....	33
Solar panel installation.....	34 & 35
Led Diagnostics.....	36
Arm blowout drawing for SW-300 & SW-350.....	37
Arm blowout drawing for SW-325.....	38

# IMPORTANT SAFETY INSTRUCTIONS

## **WARNING**

### **To reduce the risk of injury:**

READ AND FOLLOW ALL INSTALLATION INSTRUCTIONS. DO NOT THINK OF STARTING UNTIL YOU HAVE READ AND UNDERSTAND THESE DIRECTIONS. IF THERE IS SOMETHING YOU DO NOT UNDERSTAND CALL US.

**Never** let children operate or play with gate controls. Keep the remote control away from children.

Locate the control station: (a) within sight of the gate, and (b) at a minimum height of 5 feet so small children cannot reach it.

Install the Entrapment Warning Placard next to the control station in a prominent location.

For products having a manual release, instruct the end user on the operation of the manual release. Use the manual release only when the gate is not moving.

Always keep people and objects away from the gate. No one should cross the path of the moving gate.

This operator must be tested monthly. The gate must reverse on contact with a ridged object or stop when an object activates the non-contact sensors. After adjusting the force or the limit travel, re-test the gate operator. Failure to adjust and retest the gate operator properly may cause severe injury or death.

Keep gates properly maintained. Have a qualified service person make repairs to gate hardware. It takes many years of experience to make proper adjustments to gate hardware and operators.

This entrance is for vehicles only. Pedestrian must use separate entrance.

There is nothing on a gate operator that is easily repaired without a great deal of experience. Save yourself some time and call a qualified Gate Service Contractor who knows your type of gate operator.

## **SAVE THESE INSTRUCTIONS**



## **INSTALL THE GATE OPERATOR ONLY WHEN YOU HAVE READ THE FOLLOWING:**

- \*Confirm that the gate operator being installed is appropriate for the application.
  - \*Confirm that the gate is designed and built according to current published industry standards.
  - \*Confirm that all appropriate safety features and safety accessory devices are being incorporated, including all entrapment protection devices.
  - \*Make sure that the gate works freely before installing the operator.
  - \*Repair or service worn or damaged gate hardware before installation of the operator.
  - \*Eliminate all gaps in a sliding gate below a 6 foot height that permits a 2 ¼ inch sphere to pass through any location, including the area of the adjacent fence covered when the gate is in the open position.
  - \*Eliminate all gaps in a swinging gate below a 4 foot height that permit a 4 inch sphere to pass through any location, including the hinge area of the gate.
  - \*Operator must be disconnected from the power source before attempting any installation of accessories.
  - \*Install this gate operator according to our installation instructions.
  - \*Adjust the operator clutch or load sensing device to the minimum force setting that will still allow for reliable gate operation.
  - \*Install the operator inside the fence line(do not install the operator on the public side of fence line).
  - \*Install a proper electrical ground to a gate operator.
  - \*Controls intended for user activation must be located at least six feet (6') away from any moving part of the gate and where the user is prevented from reaching over, under, around or through the gate to operate the controls. Outdoor or easily accessible controls shall have a security feature to prevent unauthorized use.
- The Stop and/or Reset button must be located in the line-of-sight of the gate. Activation of the reset control shall not cause the operator to start.
- \*Install a minimum of two(2) WARNING SIGNS, one on each side of the gate where easily visible and take pictures of the installation.
  - \*Test all safety features for proper function before placing the automatic vehicular gate into service.
  - \*Train owner/users about basic functions and safety features of the gate system, including how to turn off the power and how to operate the manual disconnect feature.
  - \*Leave safety instructions, product literature, installation manual and maintenance manual with end user.
  - \*Explain to the owner/user the importance of routine service and retesting on a monthly basis.

# DIFFERENT UL 325 CLASS TYPES

## **Class one: Residential**

A vehicular gate operator intended for use in garages or parking areas associated with a residence of one to four single families.

## **Class Two: Commercial or General Public Access**

A vehicular gate operator intended for use at a commercial location or building such as a multi-family housing unit (five or more single family units), hotel, garages, retail stores, or other buildings accessible by or servicing the general public.

## **Class three: Industrial or limited Access**

A vehicular gate operator intended for use at an industrial location or building such as a factory, loading dock area or other locations not accessible by or intended to service the general public.

## **Class Four: Restricted Access**

A vehicular gate operator intended for use at a guarded industrial location or building such as airport security areas or other restricted access locations not servicing the general public where unauthorized access is prevented via supervision by security personnel.

## **Other components required to satisfy UL 325**

Each class must have two monitored entrapment protection devices in each entrapment zone to sense and react to obstructions within two seconds.

## **The six types of obstruction sensing systems are:**

### **Type A:**

Inherent entrapment protection system. This system must sense and initiate the reverse of the gate within two seconds of contact with a solid object.

### **Type B 1:**

Non-contact sensor (photoelectric sensor or equivalent). This system shall upon sensing an obstruction in the direction of travel of the gate, reverse the gate within a maximum of 2 s.

### **Type B2:**

Contact sensor (edge device or equivalent). This system shall, upon sensing an obstruction in the direction of travel of the gate: Initiate the reversal of the gate with a maximum of 2 s.

### **Type C:**

Inherent force limiting, inherent adjustable clutch or pressure relief valve.

### **Type D:**

Actuating device requiring continuous pressure to maintain opening or closing motion of the gate.

**All of All-O-Matic Inc's Gate operators conform to the most ridged Class One.**

# CONCRETE PAD FOR SW-325DC

**SW-325 Dimentions Chart**

Gate length	A	B	C	D	Minimum Distance
Less than 12'	36"	26"	13"	46"	34"
13'-15'	42"	32"	13"	52"	37"
16'-22'	48"	38"	13"	58"	40"



Use red head Bolts  $\frac{1}{2}$ " X  $3\frac{1}{2}$ "

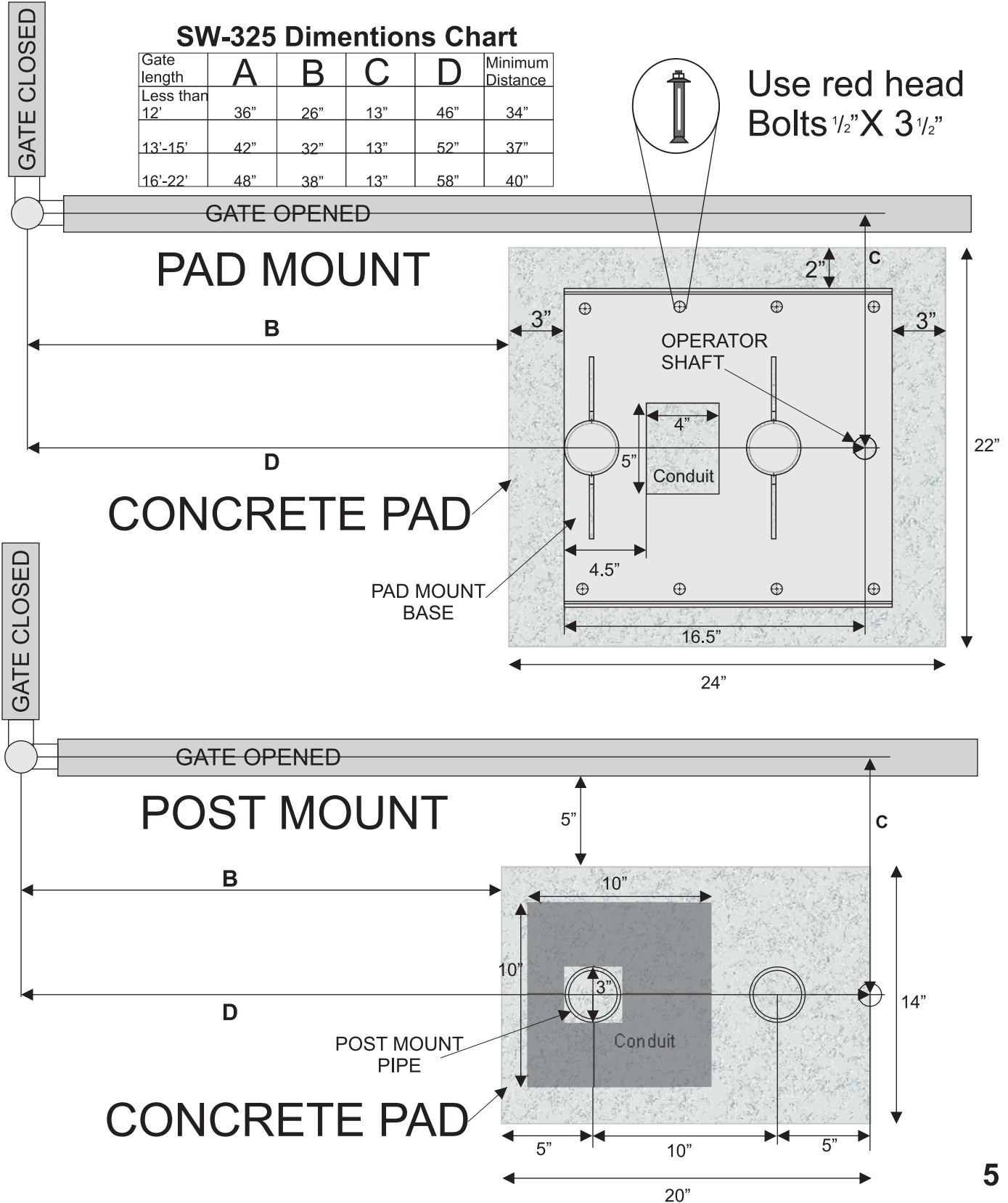

# SW-325DC

## ARM AND OPERATOR DIMENSIONS

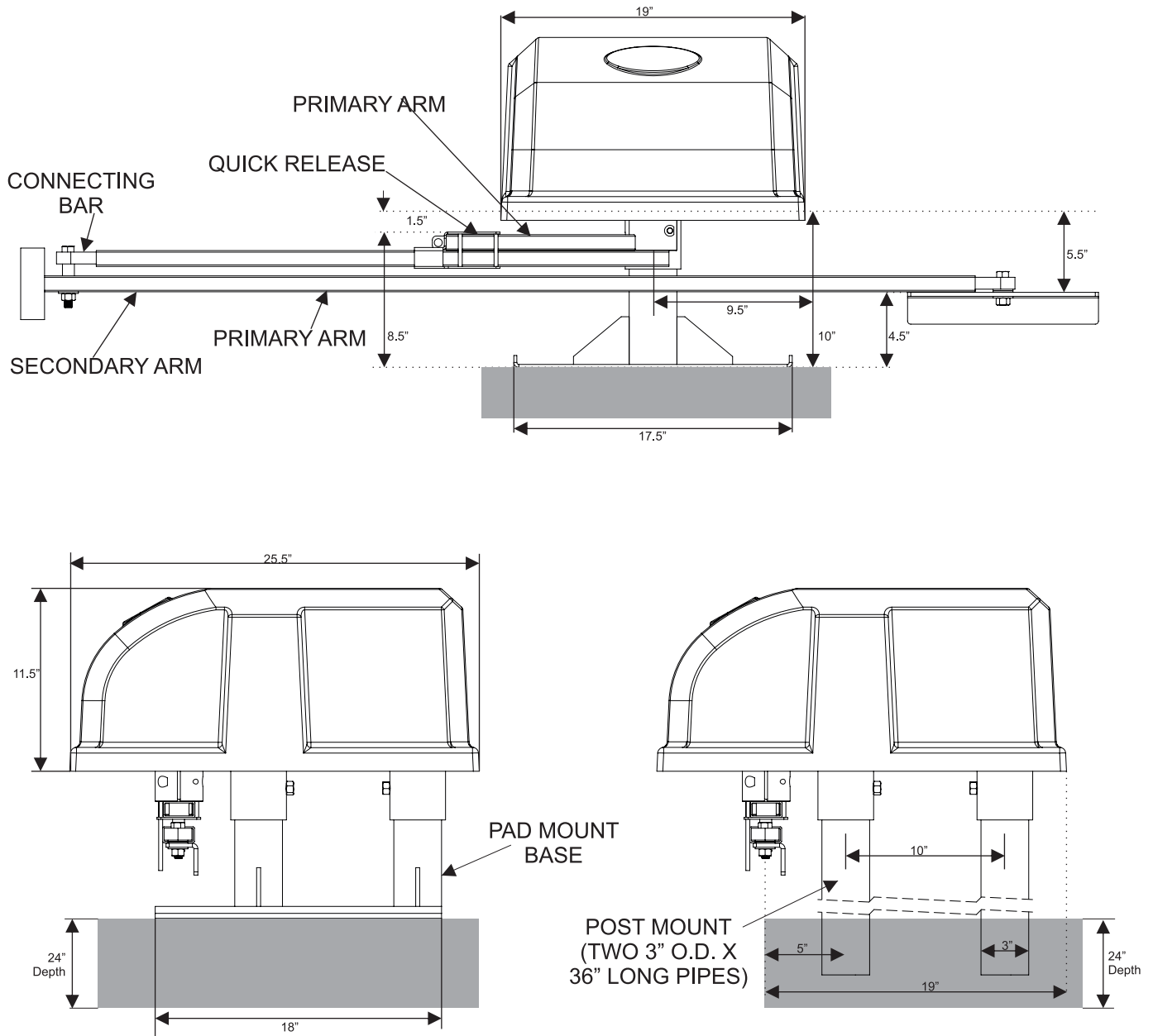

Concrete pad recommended depth is 24". But local building codes and soil conditions should be taken into consideration. Reinforced concrete is recommended.

# CONCRETE PAD FOR SW-300DC

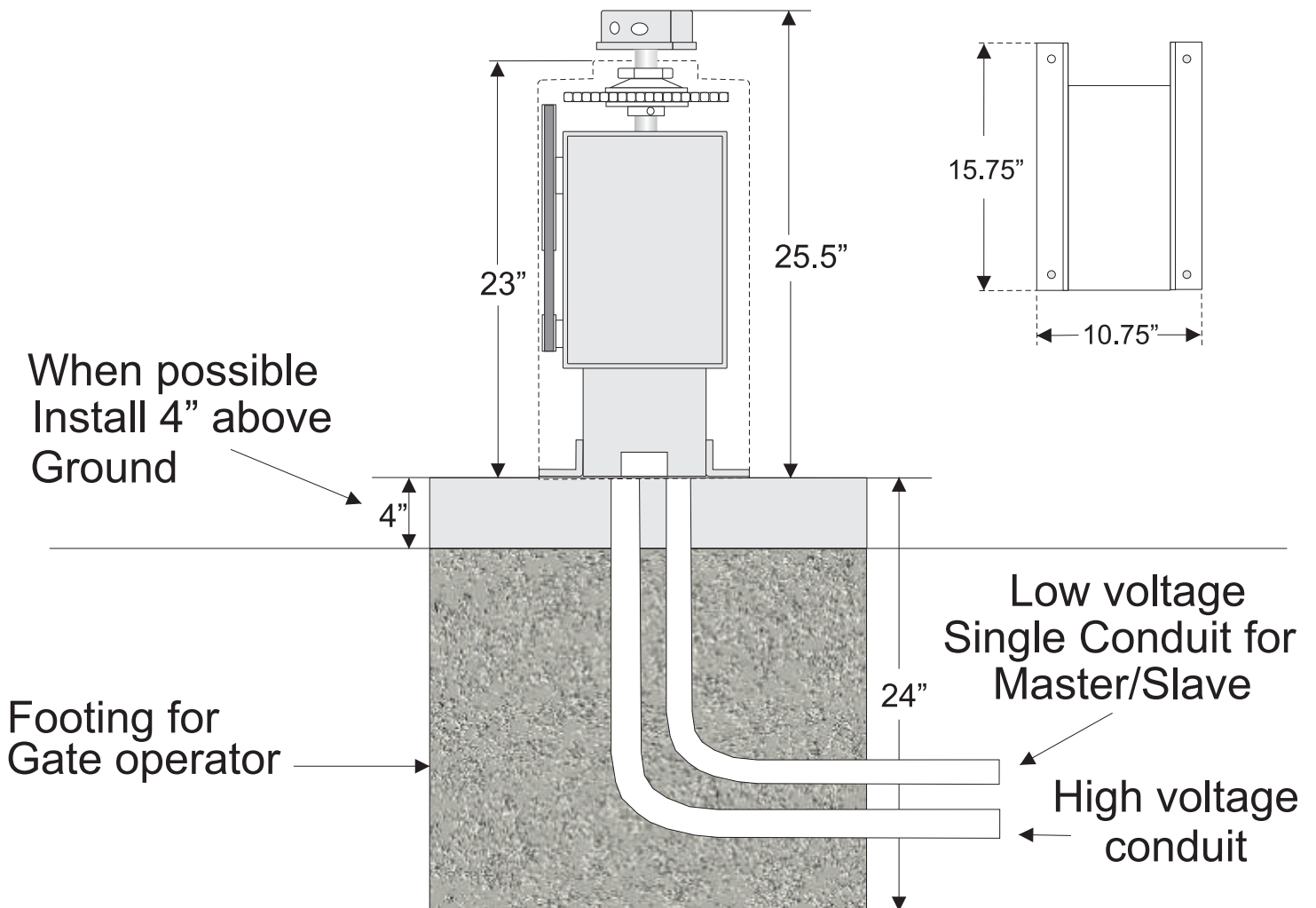
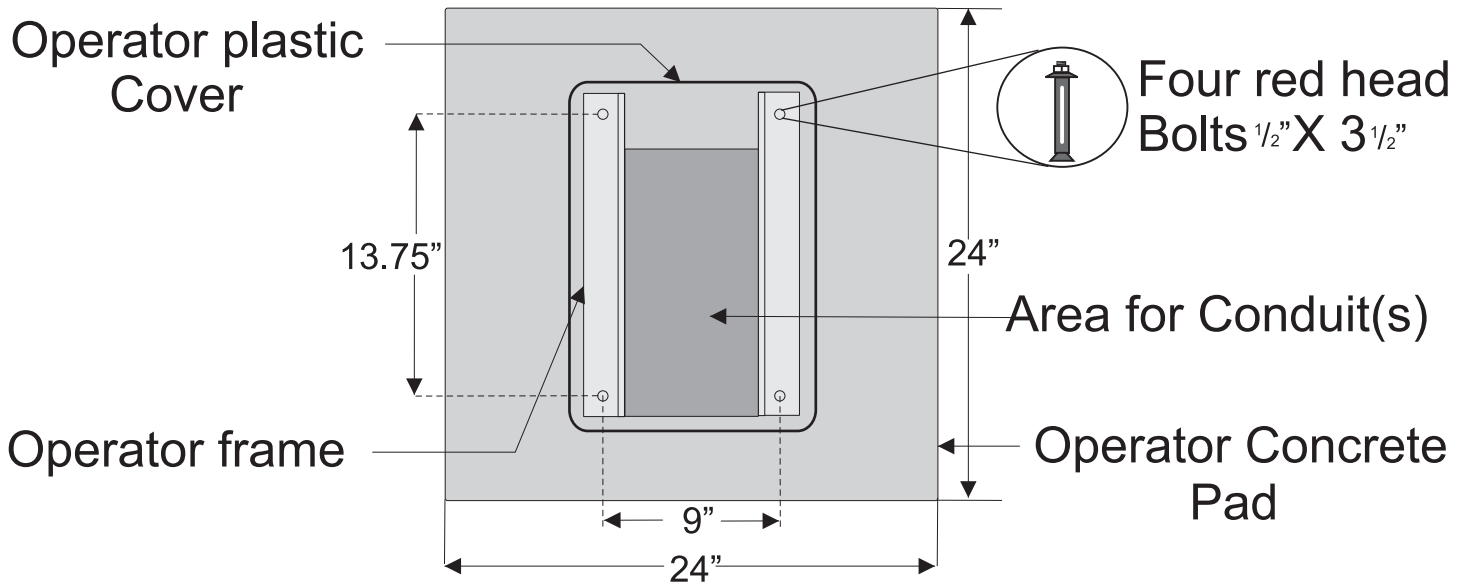

# CONCRETE PAD FOR SW-350DC

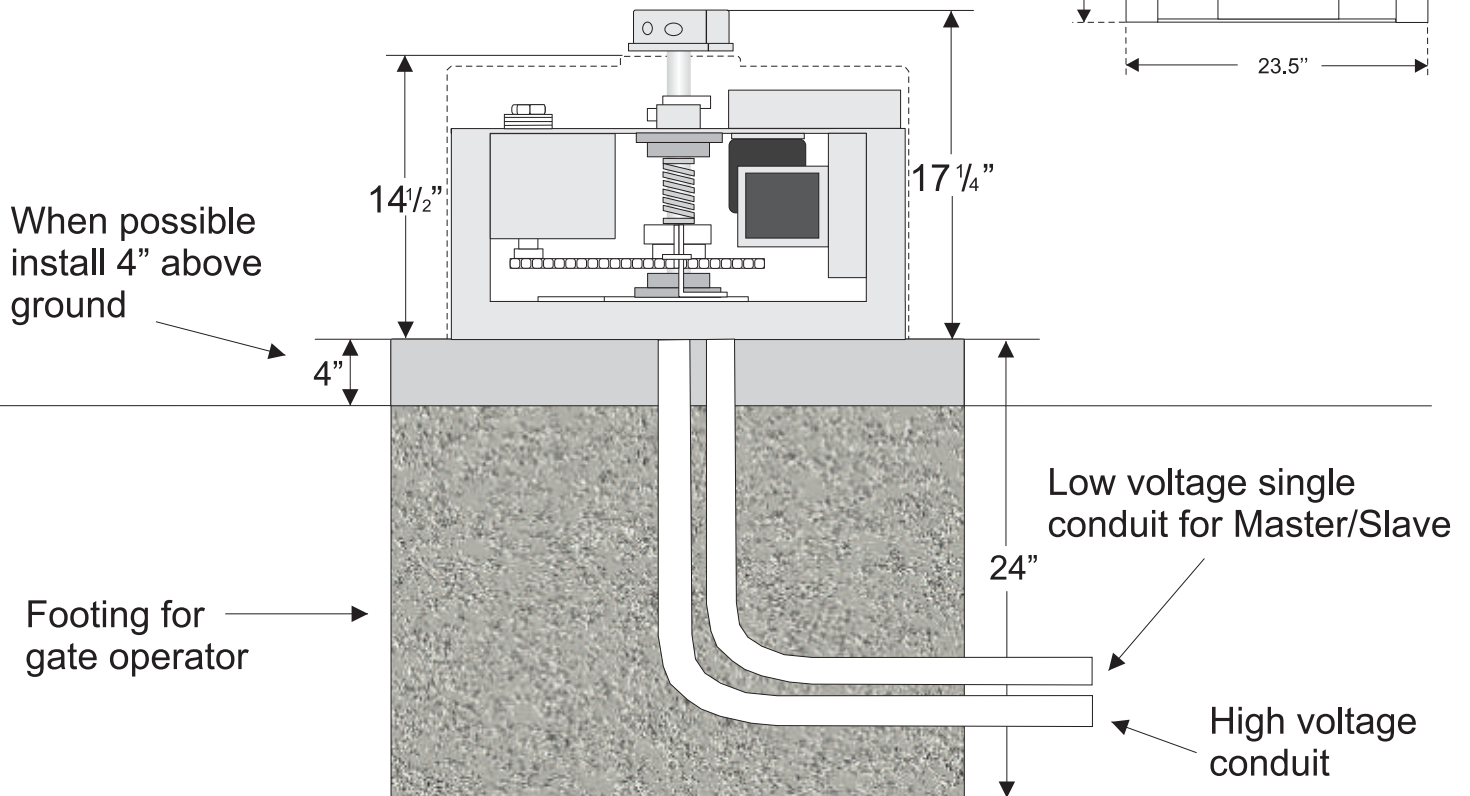
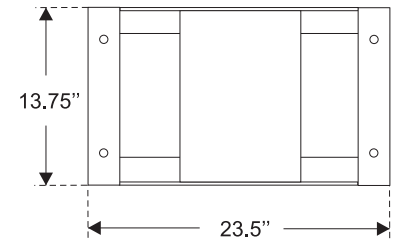
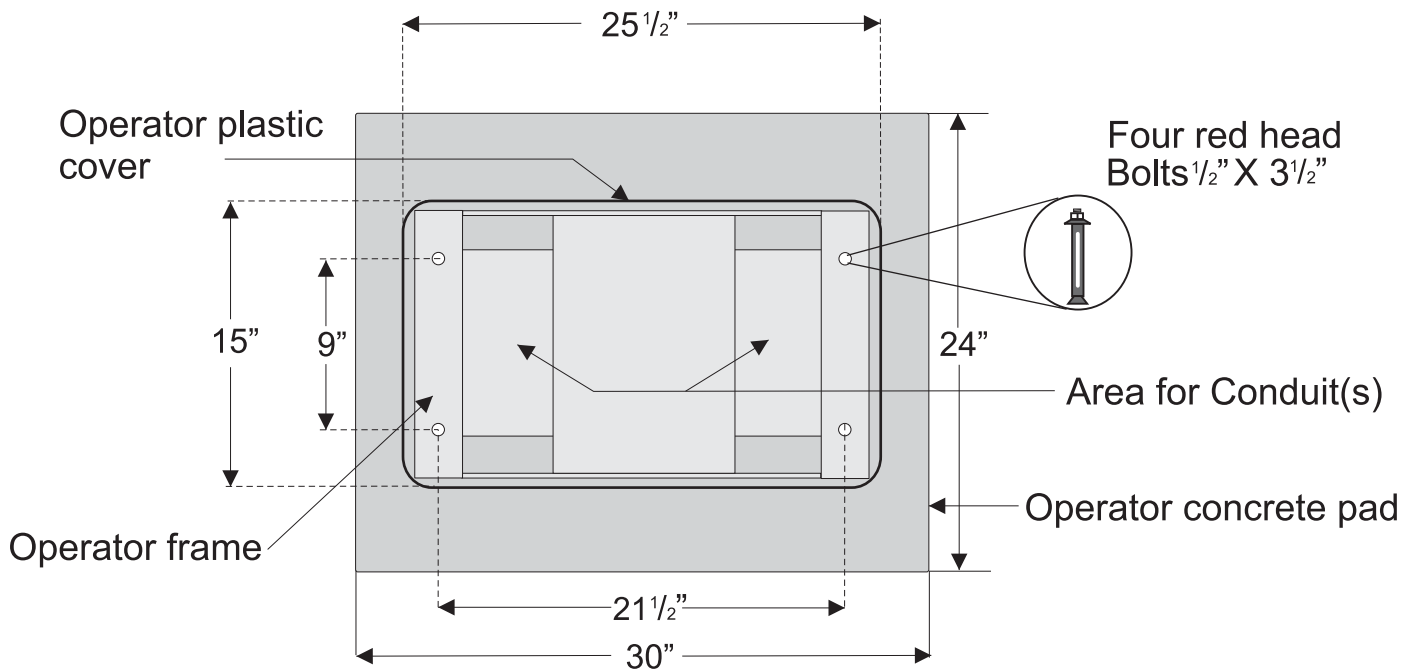



# OPERATOR AND ARM DIMENTIONS

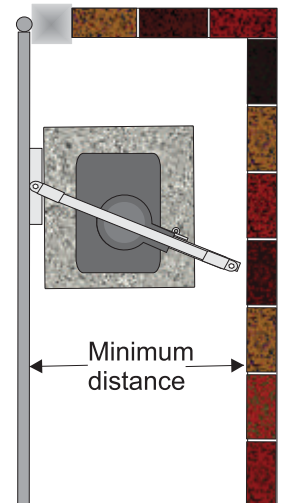
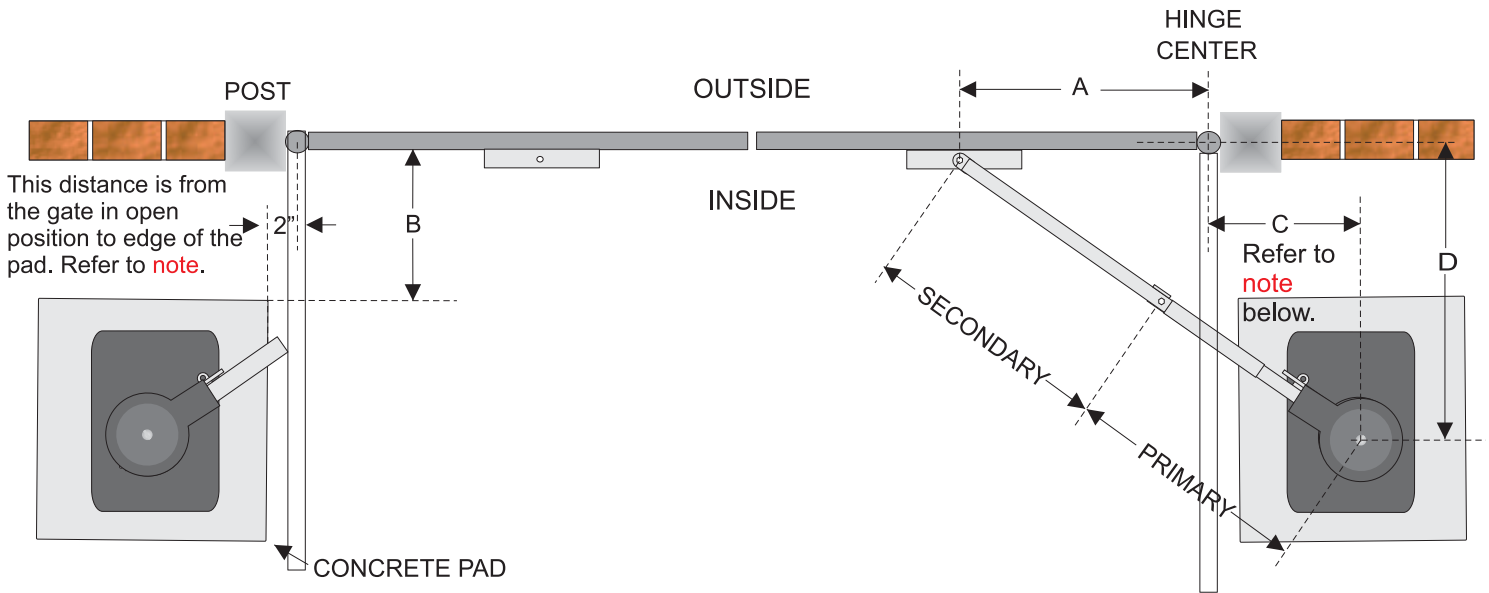

**SW-300/350 Dimentions Chart**

Gate length	A	B	C	D	Minimum Distance
Less than 12'	36"	32"	13"	46"	34"
13'-15'	42"	38"	13"	52"	37"
16'-22'	48"	44"	13"	58"	40"

**SW-325 Dimentions Chart**

Gate length	A	B	C	D	Minimum Distance
Less than 12'	36"	26"	13"	46"	34"
13'-15'	42"	32"	13"	52"	37"
16'-22'	48"	38"	13"	58"	40"

- A:** Distance between the gate bracket and the gate hinge point.
- B:** Distance between the gate hinge point and the edge of the concrete pad.
- C:** Distance from the gate in the open position to the center shaft of the operator.
- D:** Distance from the gate hinge center back to the operator center shaft.
- Minimum distance:** Is the minimum distance required behind the open gate. If the distance between the open gate and the back wall is between 20" and 33" refer to compact installation.

**Note:** The 2" distance shown above is from the gate in the open position to the edge of the pad. If the gate must open more than 90 degrees, the pad needs to move back accordingly. The distance between the open gate and the pad needs to remain 2". The distance "C" also needs to move back accordingly if the opening is more than 90 degrees.



# OPERATOR AND ARM LAYOUT

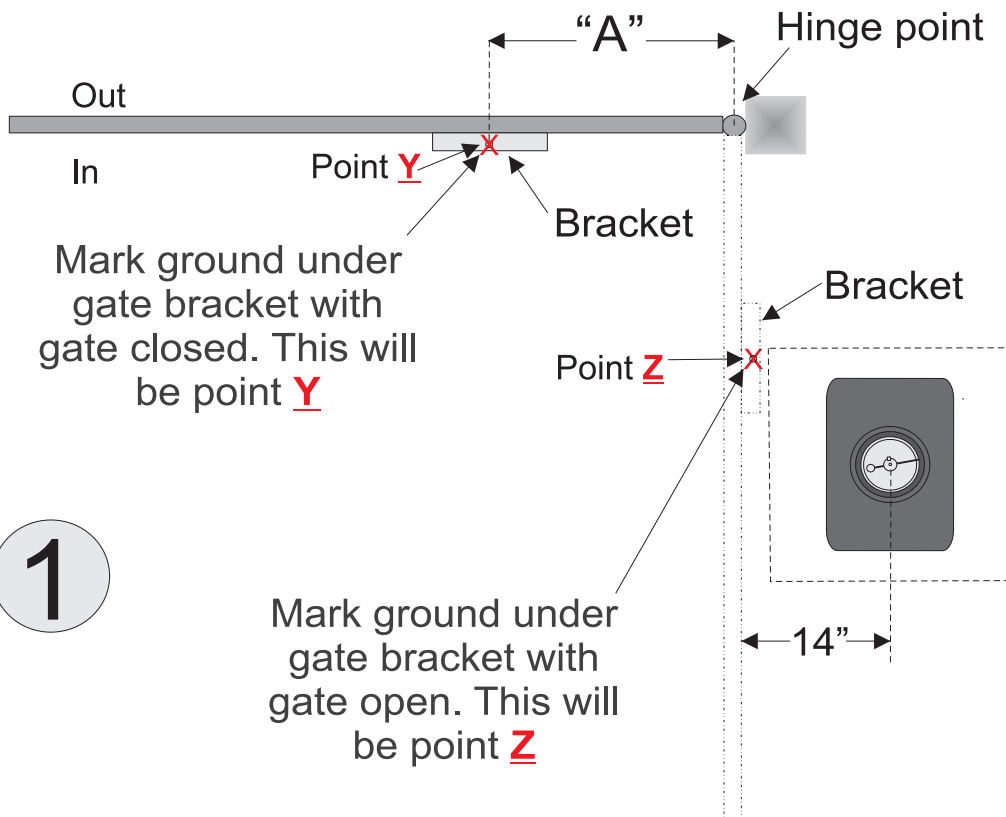

1

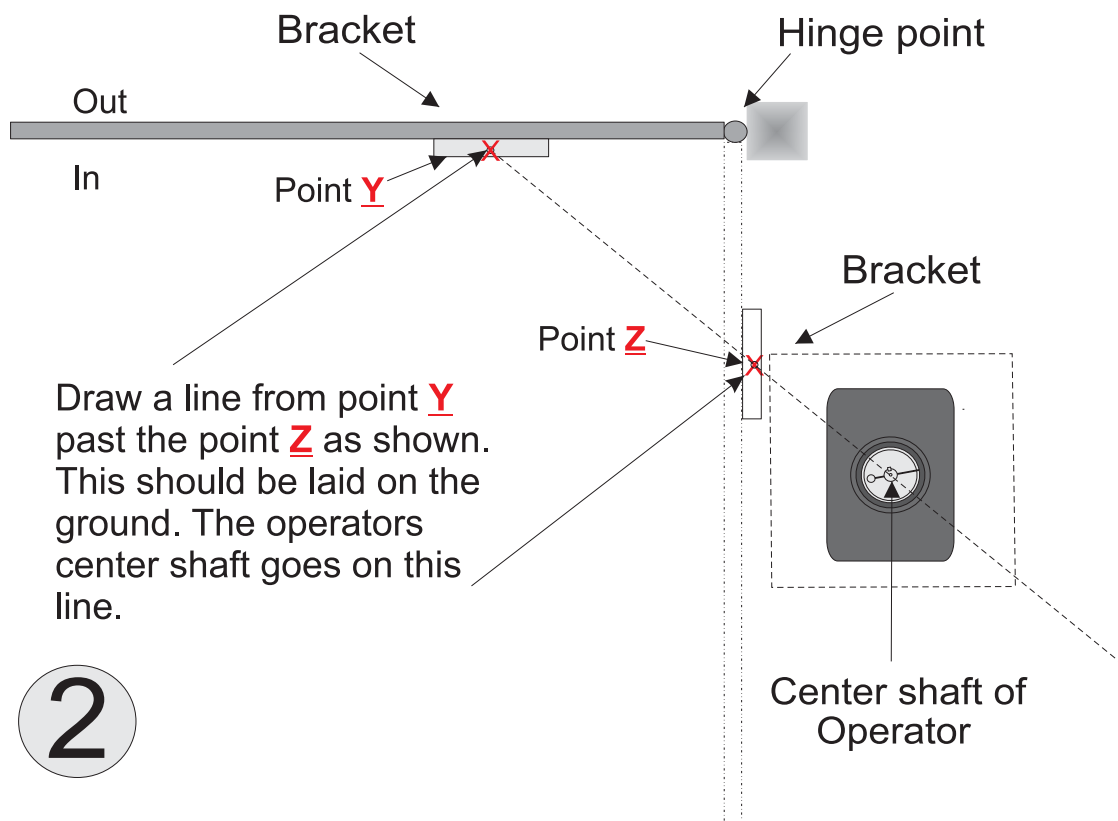

2

# ARM LAYOUT & OPERATOR PLACEMENT CONTINUED

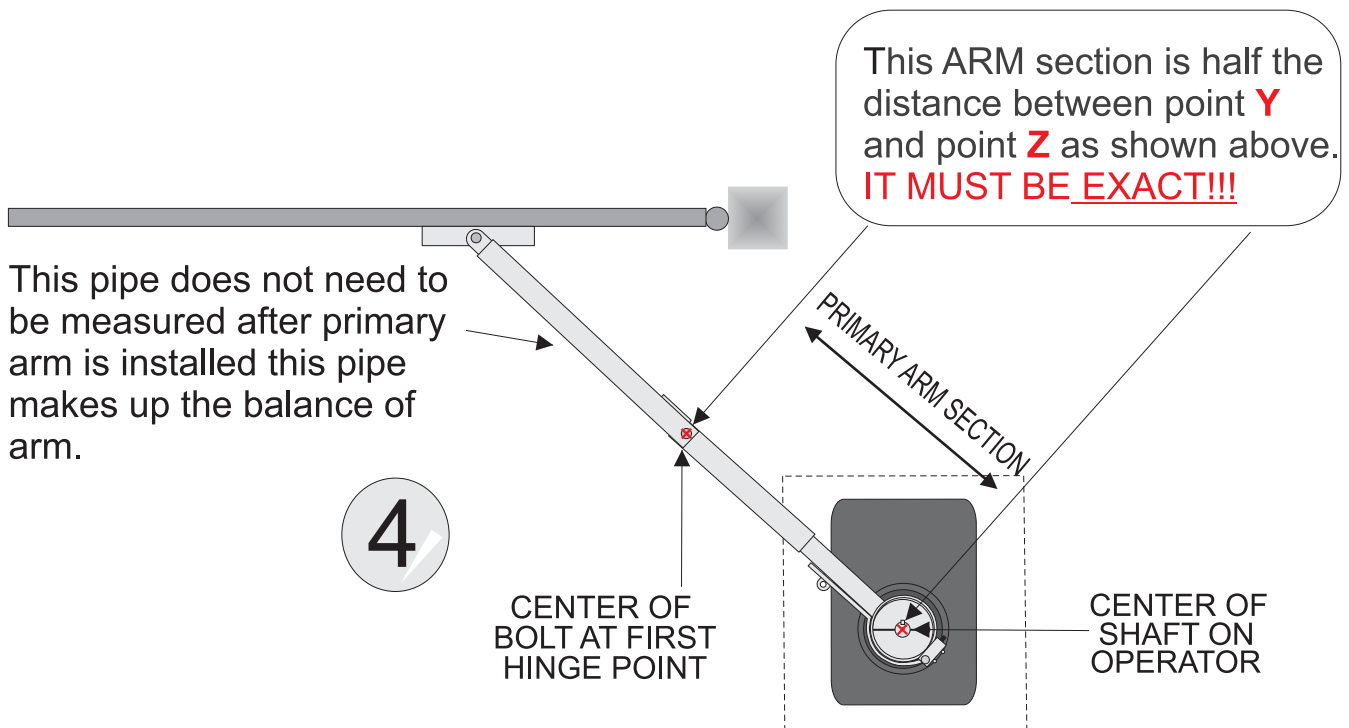
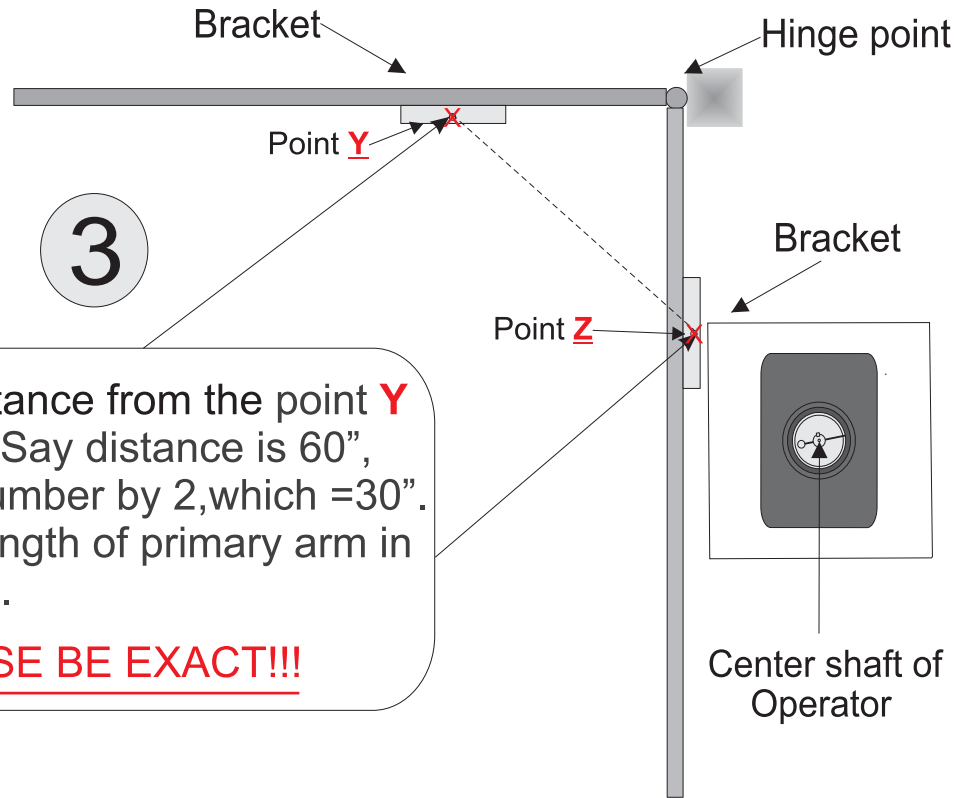

# SWINGER COMPACT INSTALLATION

To use this installation the gate must be 12' or less.

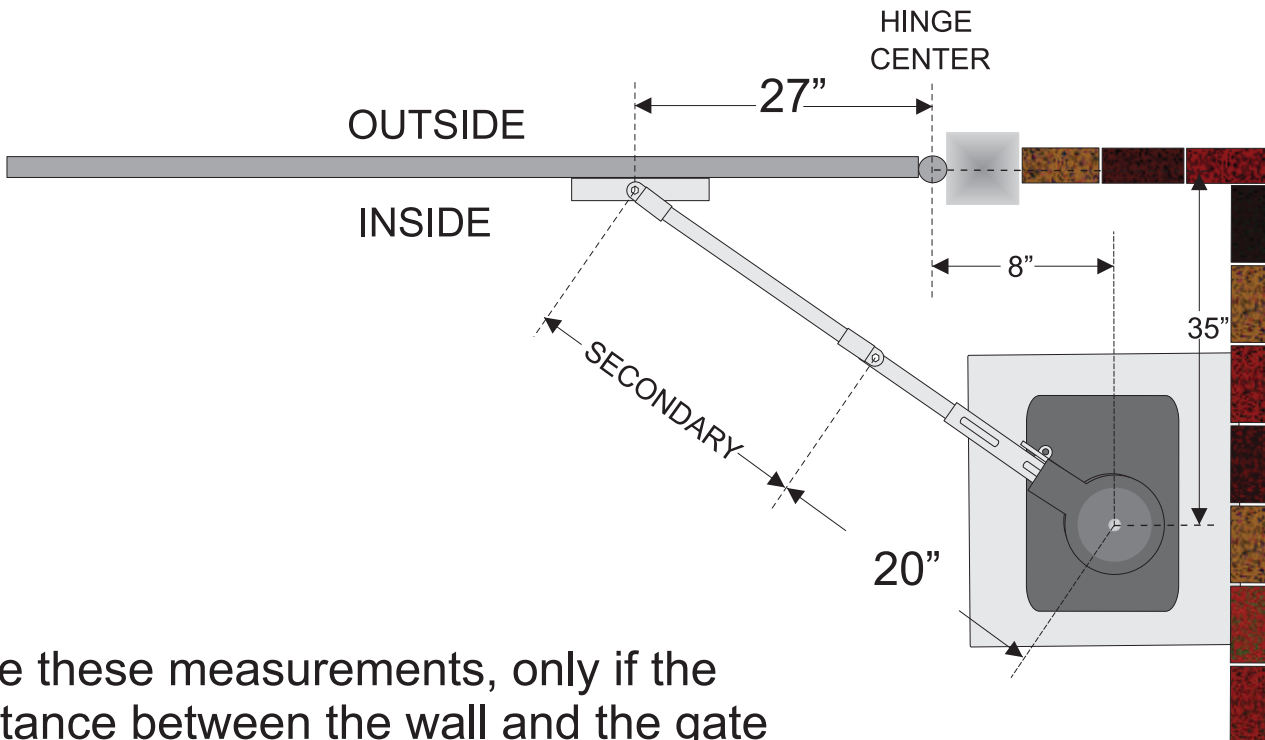

Use these measurements, only if the distance between the wall and the gate in the open position is 20" to 34". If you have more than 34" refer to standard installation.

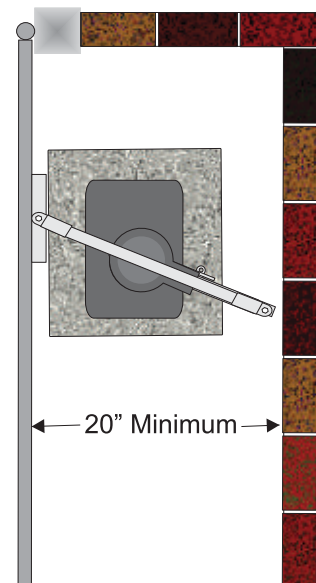

# SW-300 & SW-350 TORQUE LIMITER AND ARM ADJUSTMENT

The torque limiter is shipped loose (not adjusted). You must use a 20" pipe wrench to adjust the large torque limiter nut on the operator as shown in the images below.

Tighten torque limiter nut until arm does not slip when the operator is running.

Also run gate and grab gate at mid cycle to make sure torque limiter will slip. This is an important adjustment, so please take your time and do it right.

Torque limiter adjusting nut.

20" Pipe wrench

Torque limiter adjusting nut.

Top view

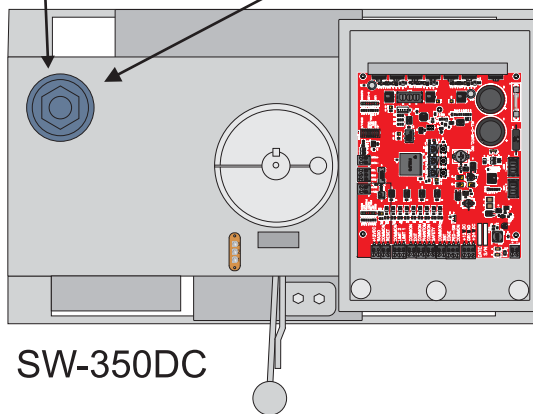

Side view

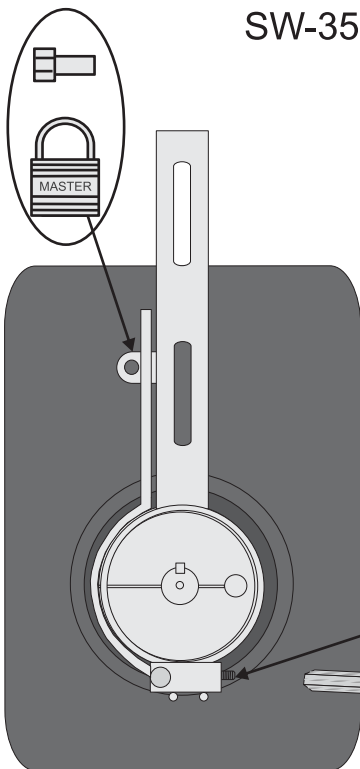
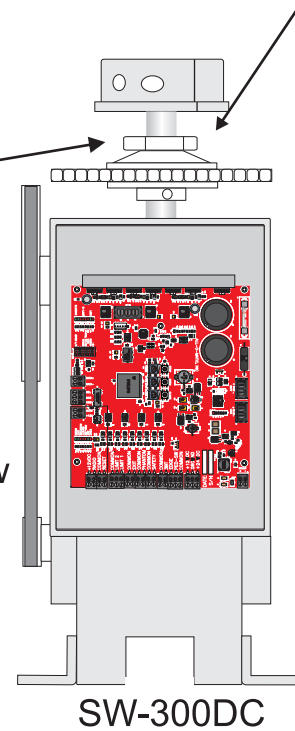

**ARM ADJUSTMENT:** Use a pad lock or a bolt to hold the arm lever in closed position. With the arm lever closed tighten the arm adjusting screw as tight as possible.

**ARM QUICK RELEASE:** To release the arm with the quick release, simply remove the bolt or padlock from the arm lever and open it. Opening the arm lever will allow you to manually open the gate.

Arm adjusting screw

Allen wrench

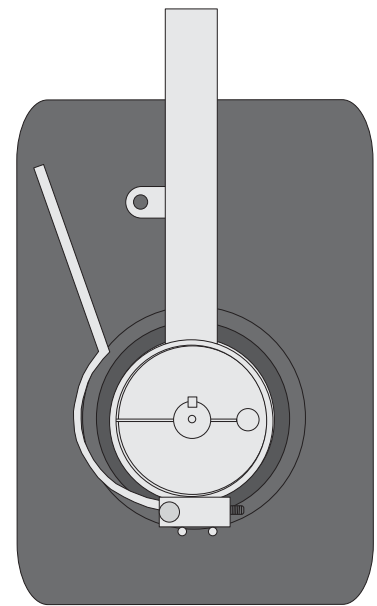

# SW-325 TORQUE LIMITER ADJUSTMENT and EMERGENCY RELEASE

- The torque limiter is shipped loose (not adjusted). You must use a wrench to adjust the large torque limiter nut shown in the images below.
- Tighten torque limiter nut until clutch does not slip when the operator is running.
- Also run gate and grab gate at mid cycle to make sure torque limiter will slip. This is an important adjustment, so please take your time and do it right.

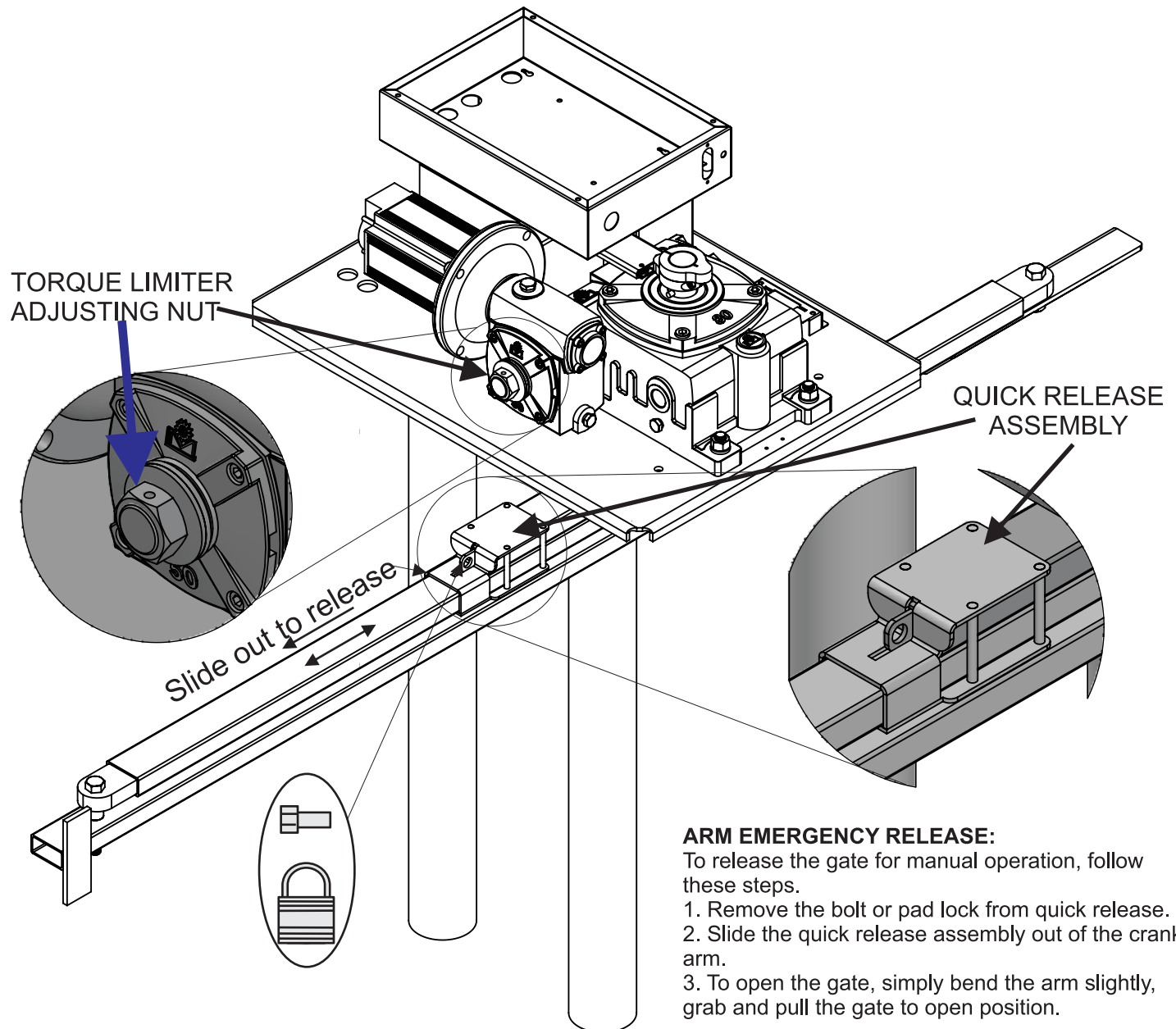

## ARM EMERGENCY RELEASE:

To release the gate for manual operation, follow these steps.

1. Remove the bolt or pad lock from quick release.
2. Slide the quick release assembly out of the crank arm.
3. To open the gate, simply bend the arm slightly, grab and pull the gate to open position.

To put it back in automatic operation, align the primary arm with the crank arm and slide the quick release assembly back into the crank arm and lock it with a bolt or pad lock.

# GATE TRAVEL ADJUSTMENT

Locate limit switch.

Step 1: Turn the **power off** on operator.

Step 2: Use an allen wrench to loosen up the limit cams. Turn the limit Cams to desired direction.

Step 3: tighten the allen screw.

Step 4: Turn the operator back on.

Step 5: Run gate operator. If more adjustment is needed, repeat the steps.

**NOTE:** Operator will run slow the fist cycle of operation. It's part of the initial learning process.

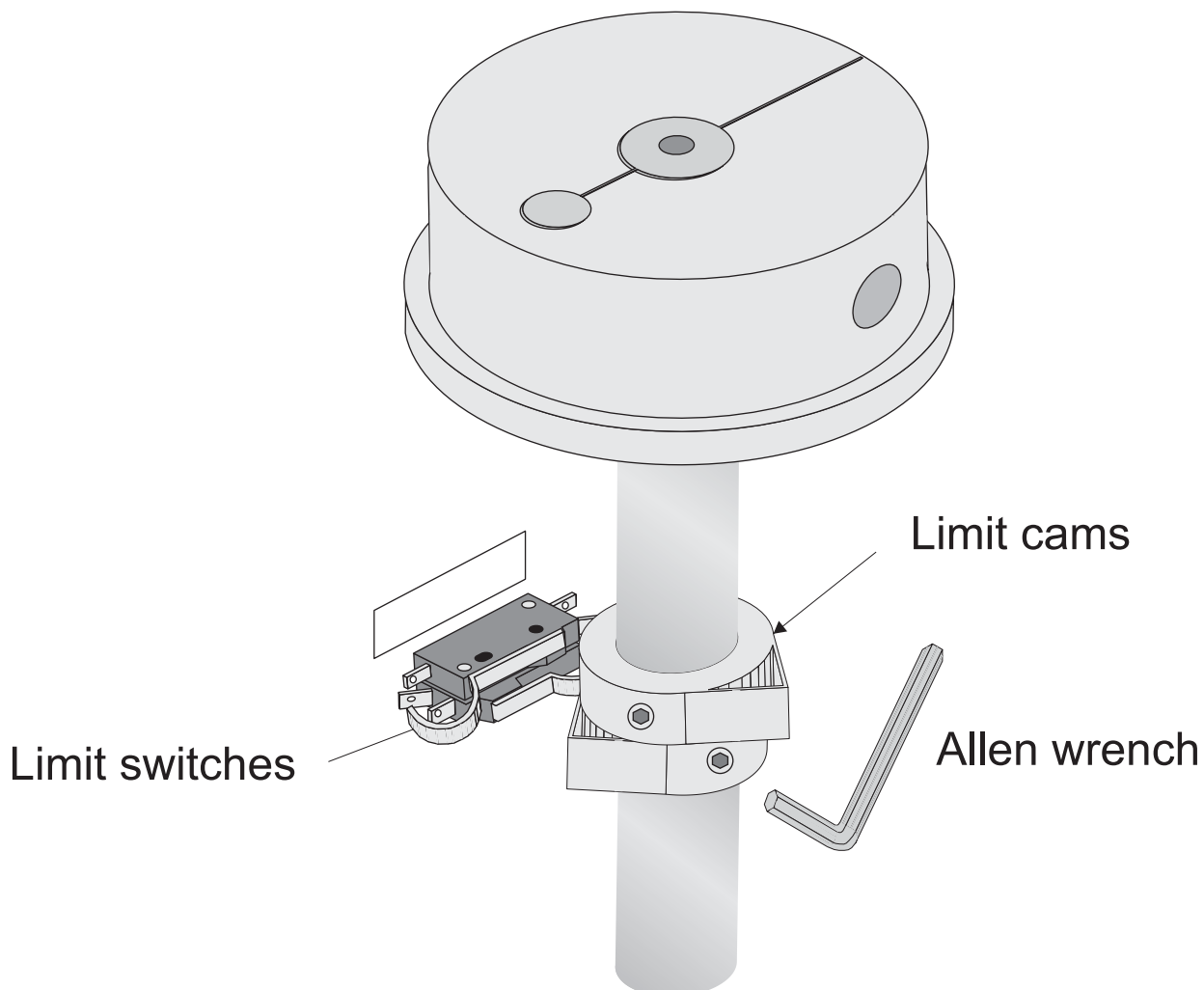

# OPENING DIRECTION SETTINGS

Use **OPEN L/R** dipswitch to change the opening direction on the operator. **OFF** for Right hand opening, **ON** for Left hand opening.

LED's will show opening or closing directions when gate is running.

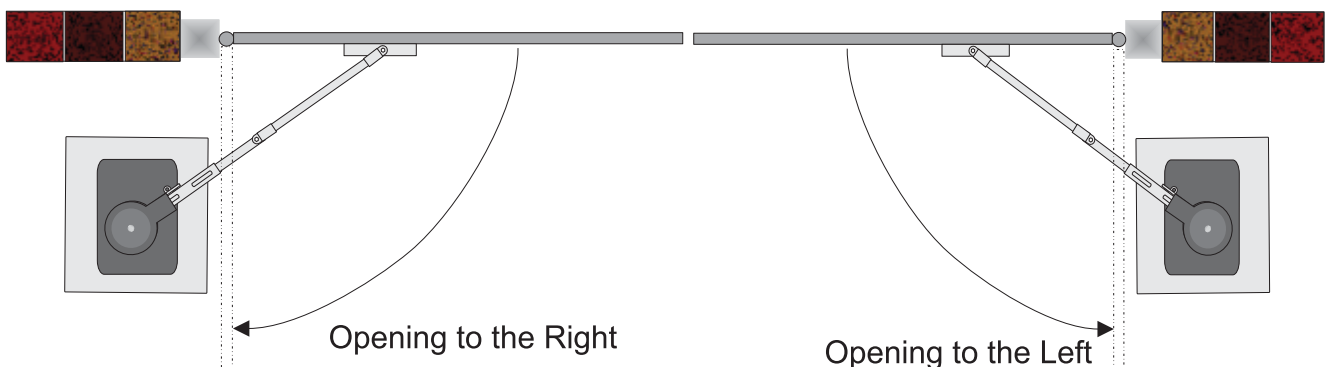
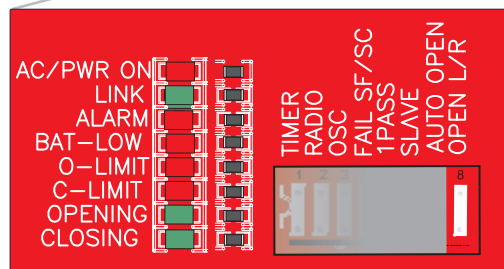
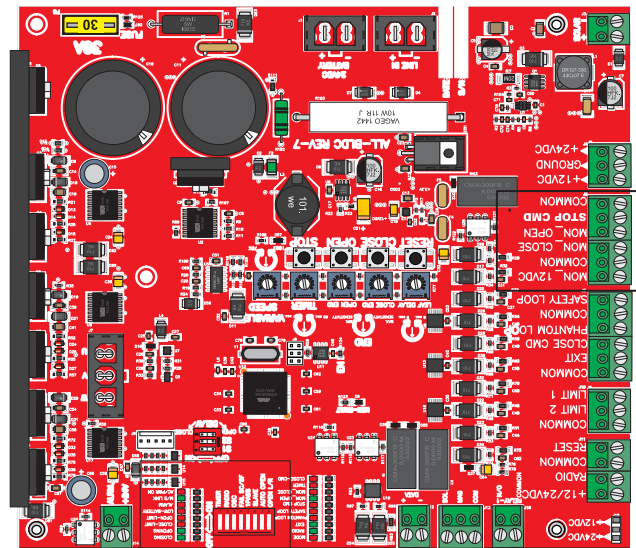



# ELECTRICAL CONNECTION

**OPERATORS MUST BE PROPERLY GROUNDED!**

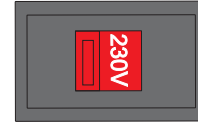
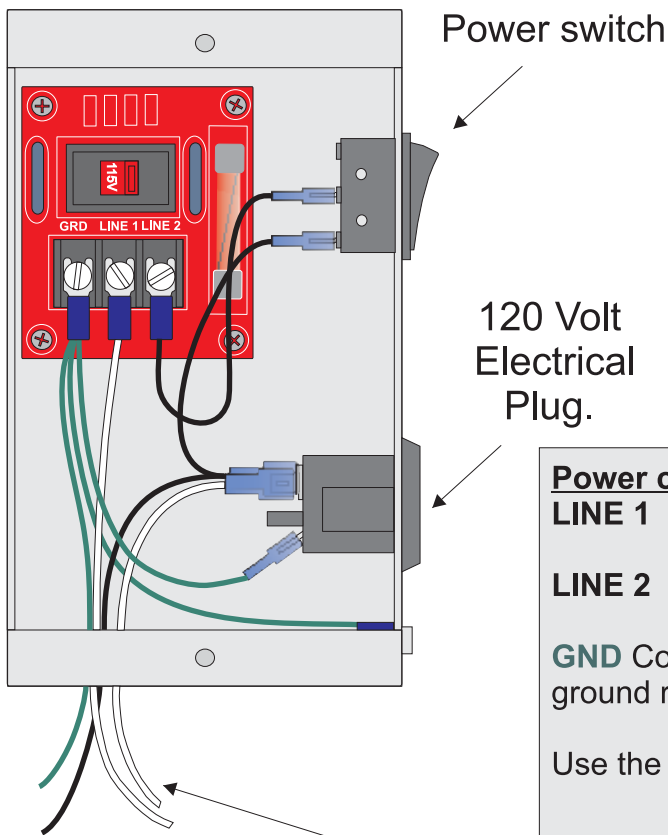

**NOTE:** When applying 230V to operator make sure voltage switch is flipped to 230V position.

Power connection	115VAC	220VAC Single Phase
LINE 1 =	115V N	220V LINE 1
LINE 2 =	115V HOT	220V LINE 2

**GND** Connect to ground. Use a proper **ground rod** for a ground reference.

Use the shortest and thickest wire possible for ground.

For power, a minimum of a **15-Amp** dedicated circuit breaker is needed.

**NOTE:** To use the 120VAC accessory outlet, connect white wire from the outlet to neutral. Only when using 120VAC as the power source.

**For power wire enclosure use UL listed conduits.**

All gate operators **MUST** be properly grounded.

A proper ground in a gate operator installation minimizes or prevents damage from an electrical charge, such as a near lightning strike or an electrical static discharge.

Use a single wire for the ground. **DO NOT** splice two wires for the ground. If the wire breaks or is cut, replace it with a single length. **NEVER** use two wires for the ground.

Check with your City code for proper earth ground rod type and proper grounding procedures.

# SWINGER LOOP LAYOUT

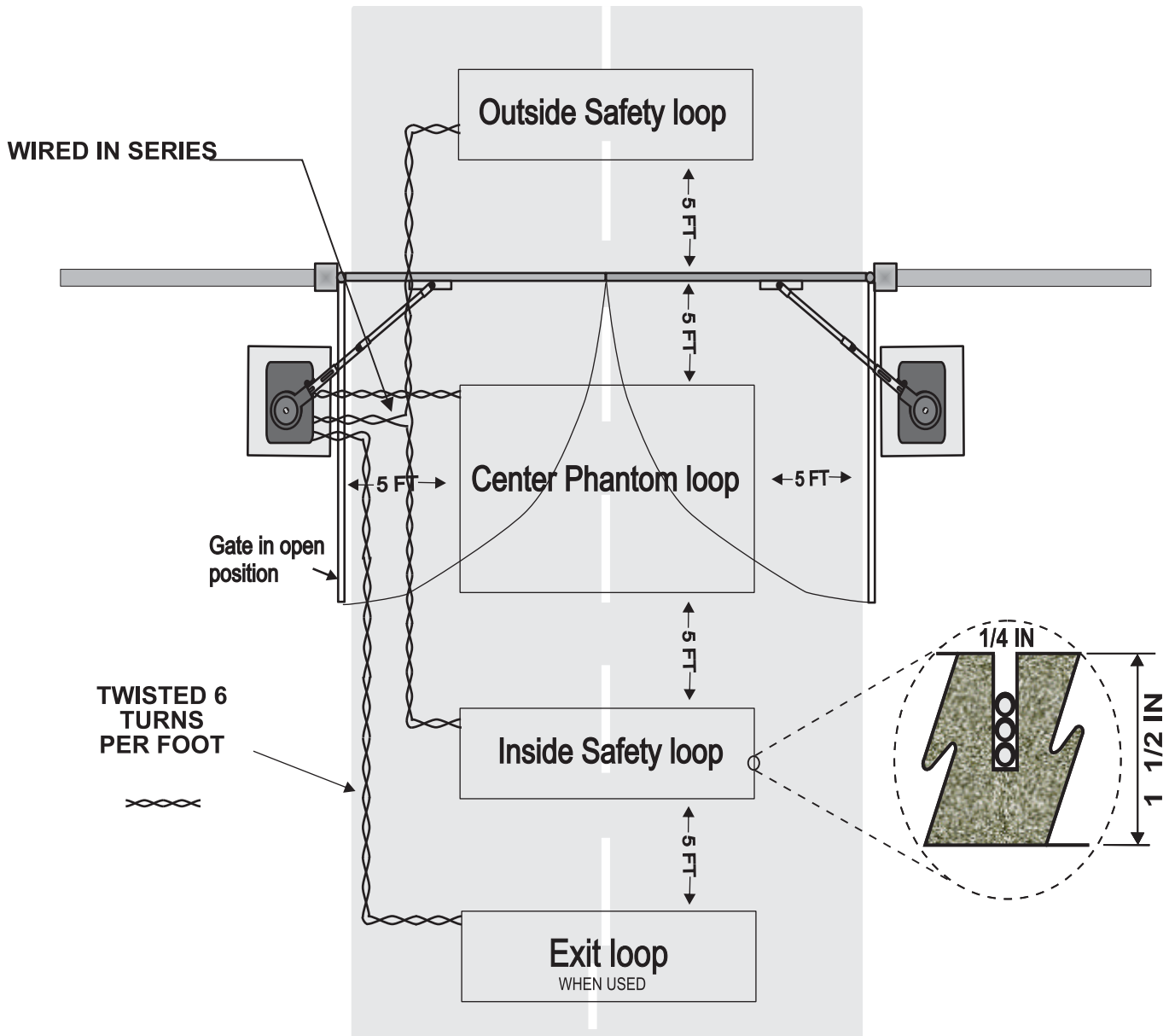

This is a normal loop layout. Remember when connecting to an All-O-Matic circuit board you use the **normally closed contacts** from your safety loop detector and **normally open contacts** from the exit loop. You must twist your wires from your exit point of the saw cut all the way to the circuit board, no exceptions.

# GENERAL LOOP INSTALLATION GUIDELINES

The following loop installation guidelines are for installing typical driveway loops for access control applications (i.e. parking gates, sliding gates, swing gates etc...) Always consult with loop detector manufacturers for specific equipment guidelines. This will confirm that the proper configuration and installation techniques are applied for your application.

Useful information about inductive loops:

- A. The typical sensing height is 2/3 of the shortest leg of loop (in feet)  
Therefore a 4' x 8' loop typically has a detection height of 2.6'.
- B. The inductance of a conventional four-side loop can be estimated using the formula:

$$L = P \times (T^2 + T) / 4$$

Where L = Loop Inductance in microHenries

P = Loop Perimeter in feet

T = Number of turns of wire in saw slot

Therefore a 4' x 8' loop with 3 turns would be:

$$L = (4 + 8 + 4 + 8) \times (3^2 + 3) / 4$$

$$L = 24 \times (9 + 3) / 4$$

$$L = 24 \times 12 / 4$$

$$L = 24 \times 3$$

$$L = 72 \text{ microHenries}$$

Suggested guidelines for loop installation:

Loop wires should be twisted 6 turns per foot, and twisted from saw slot to the detector. If possible start twisting the wires from the edge of the loop.

All 90 degree corners should be chamfered so that the course of the wire does not change direction sharply but rather at shallower angles of 45 degrees or less. Core drilling of the corners achieves the same effect but can still lead to failure due to sharp edges remaining in the corner area.

Loop Perimeter	# of Turns
6' - 12'	6
13' - 20'	5
21' - 60'	4
61' - 240"	3
241 & Up	2

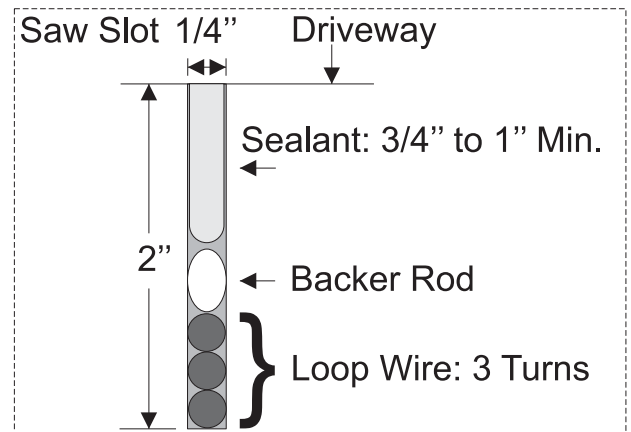
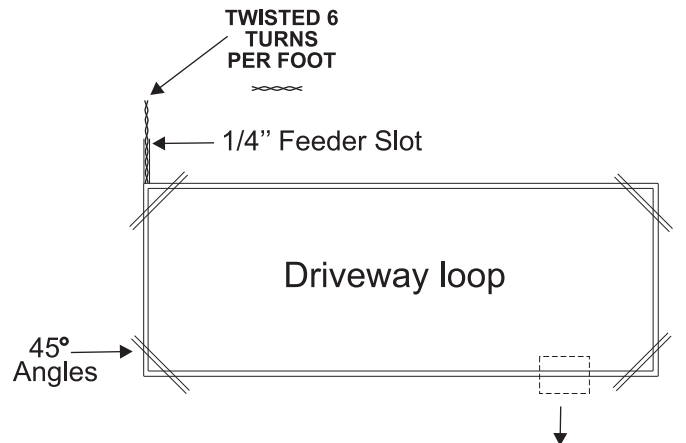

# ACCESSORY CONNECTIONS

The circuit board **12 & 24VDC** outputs provide up to **500mAmps** each input of power for accessories. More than two or three accessories will require a separate power supply.

**NOTE:** 12 & 24VDC Accessories only.

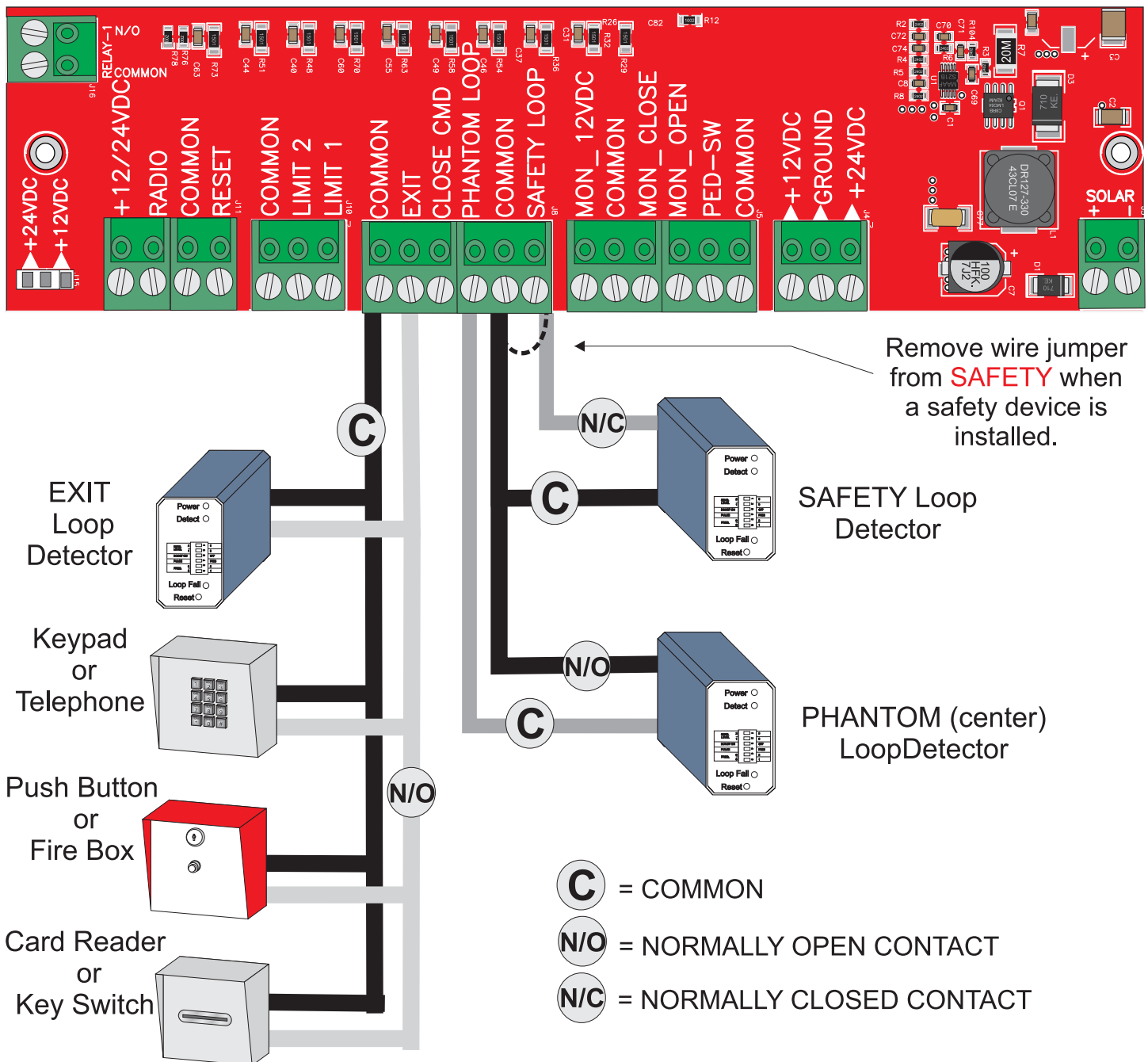



# LPR-1 LOOP RACK IN ATALLATION

This is a **typical** loop configuration for a gated driveway. Remember when connecting to an All-O-Matic circuit board the safety (reverse) uses **normally closed contacts** from the loop detector, the wire jumper from the safety connector needs to be removed when a safety loop is installed.

You must twist your wires from your exit point of the saw cut all the way to the loop detectors, no exceptions.

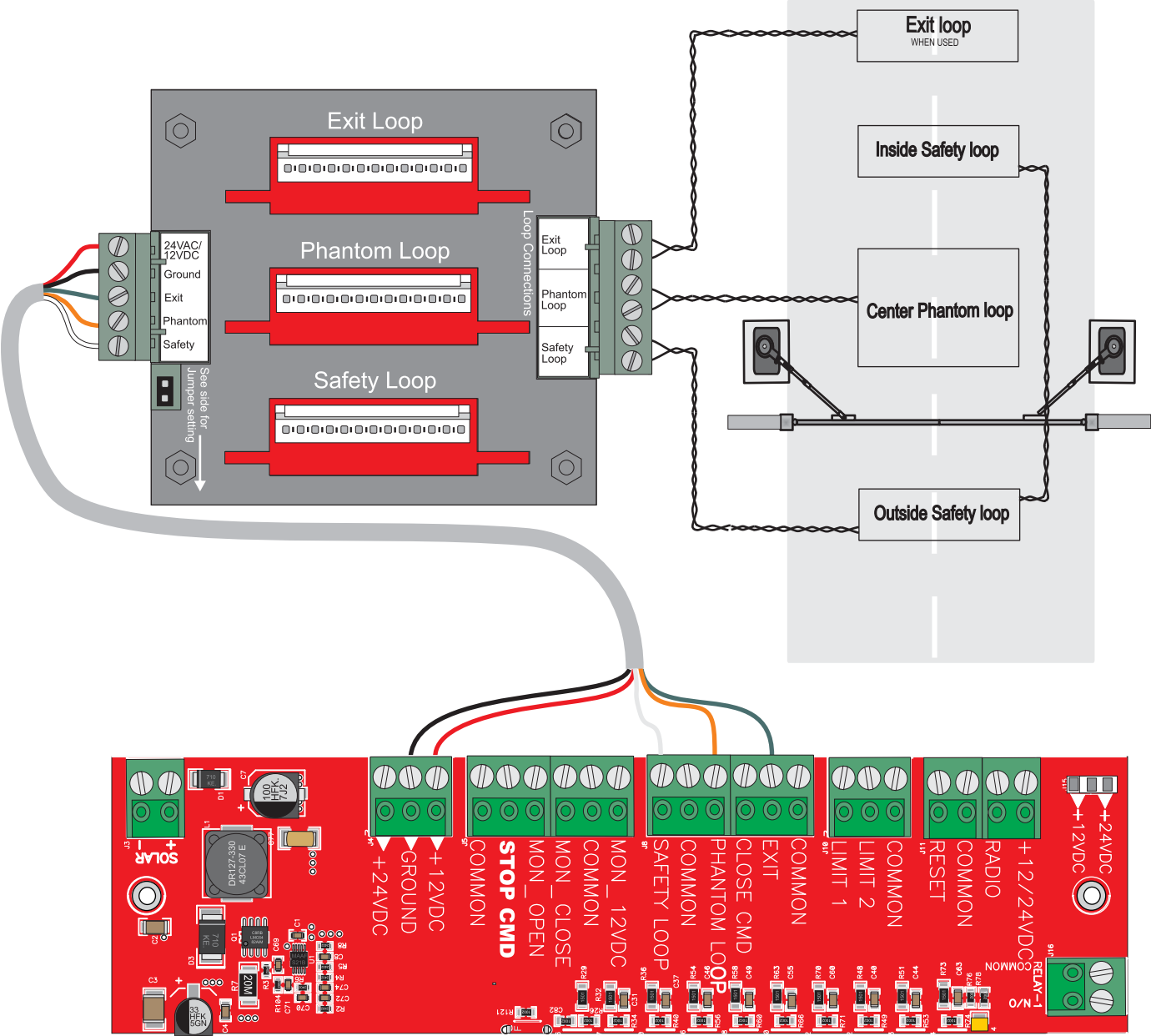

### Compatible Detectors

Brand	Model No.	Jumper setting
Reno A&E	H2	<input type="checkbox"/> OFF
EDI	LMA-1500-LP	<input type="checkbox"/> OFF
Diablo Controls	DSP-40S	<input checked="" type="checkbox"/> ON

# ENTRAPMENT PROTECTION INSTALLATION FOR SWINGING GATES

A minimum of two monitored entrapment protection devices are **required** for each entrapment zone. All locations or point of contact where a person can become entrapped between a moving gate and a rigid object is considered an entrapment zone. The operator has an inherent entrapment protection (ERD) system. It requires an external monitored entrapment protection device (contact edge sensor or non-contact photoelectric sensor) for each entrapment zone prior to gate operation. The operator cycles power to the external entrapment protection device and checks for device signals. If the operator does not receive the correct feedback from the device, the gate will not operate.

Below are some samples of entrapment zones and where the entrapment protection devices should be installed.

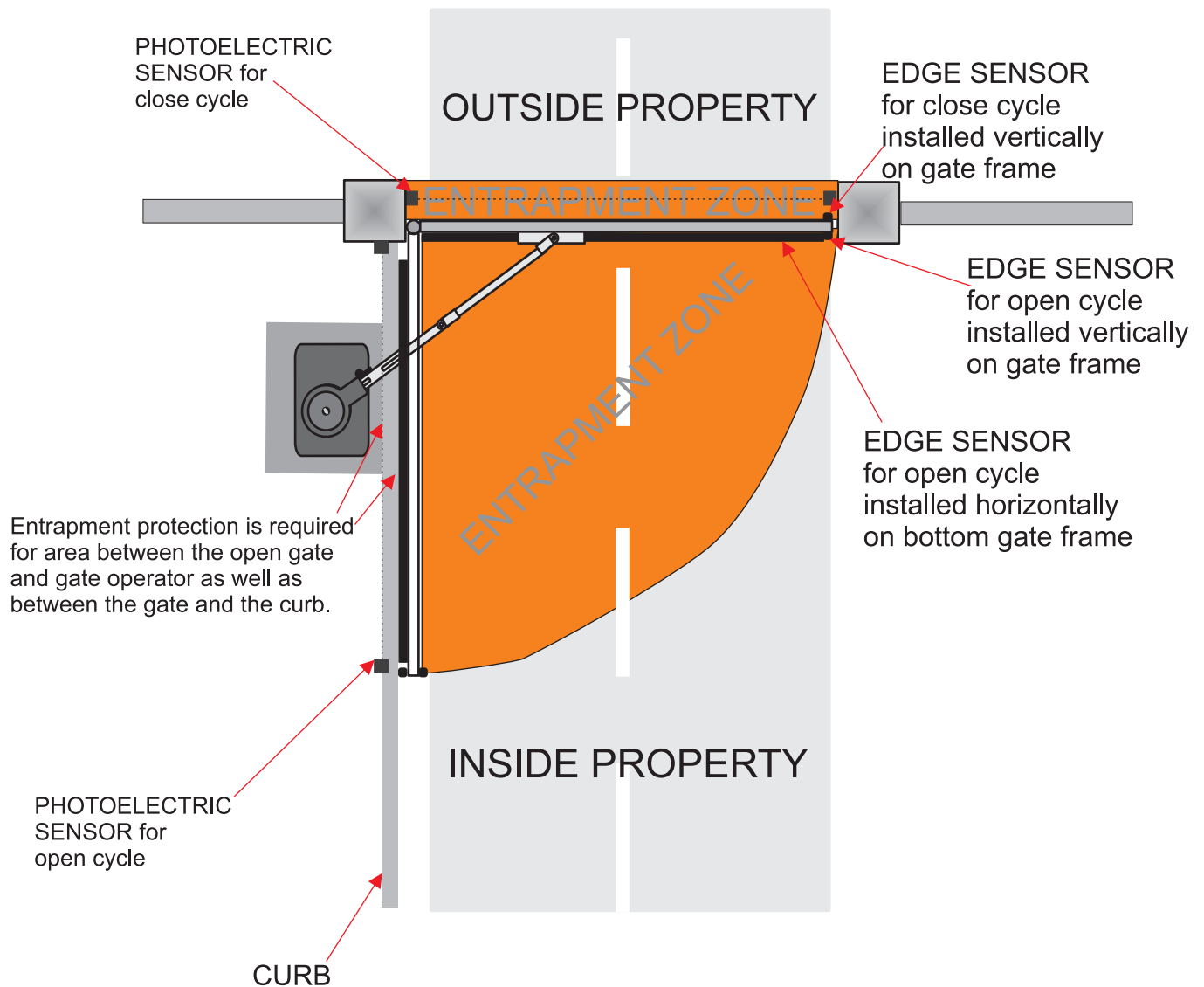

# ENTRAPMENT PROTECTION DEVICE CONNECTIONS

There are two type of entrapment protection devices that can be connected to the operator, NON-CONTACT SENSOR (PHOTO EYE) and CONTACT SENSOR (EDGE SENSORS). These inputs are for monitored ENTRAPMENT PROTECTION devices.

Wiring for brushless DC gate operators.

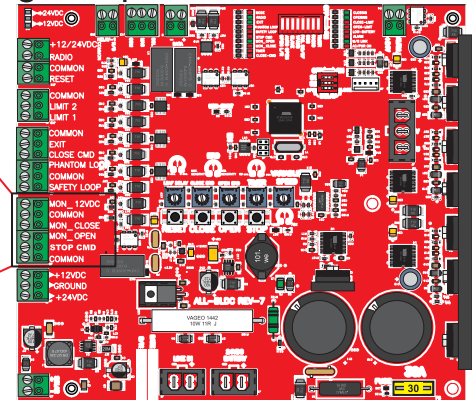
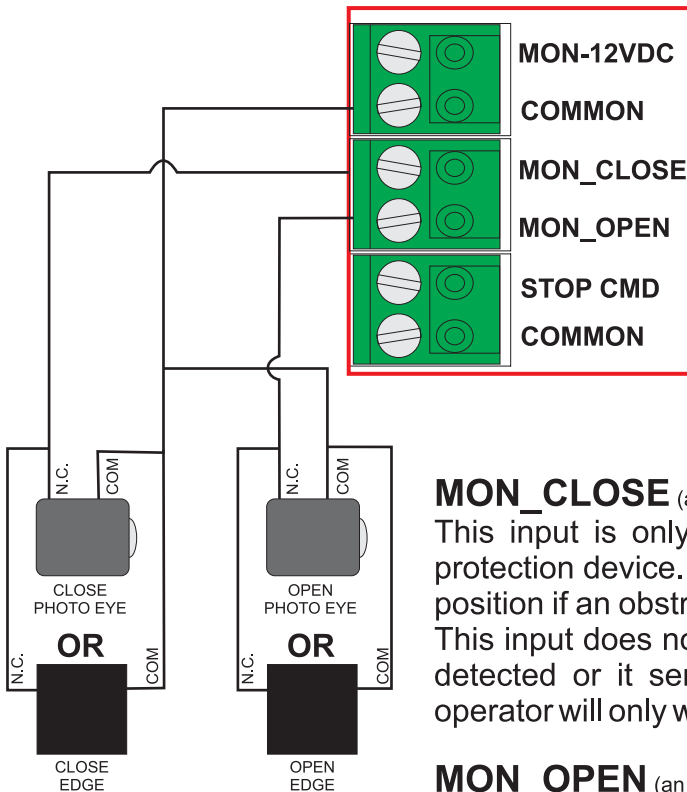

PCB model: ALL-BLDC

**MON\_CLOSE** (an LED will indicate when an obstruction is detected or device not present)  
This input is only for the close direction monitored entrapment protection device. When gate is closing it will open to the full open position if an obstruction is sensed and resets the auto close timer. This input does nothing in the opening direction. If a device is not detected or it senses a fault (**MON\_FAULT** LED will turn ON), the operator will only work on constant pressure actuated switch.

**MON\_OPEN** (an LED will indicate when an obstruction is detected or device not present)  
This input is only for the open direction monitored entrapment protection device. When gate is opening it will reverse 2 seconds and stop if an obstruction is sensed. This input does nothing in the closing direction. On power up, if a device presence is not detected the operator will assume one is not required for opening direction. If a device is connected and board detects a fault (**MON\_FAULT** LED will turn ON), the operator will only work on constant pressure actuated switch.

Monitored entrapment protection devices use four wires to connect to the board. From the device, connect **relay common** to board **COMMON** and **N.C.** relay contact to assigned **MON\_OPEN** or **MON\_CLOSE** input. Connect the power wires to the **COMMON** and **MON-12VDC**. **VERY IMPORTANT:** The **MON-12VDC** supply must be used (not the normal 12VDC terminal) to properly monitor entrapment protection devices.

Refer to the device manufacturer wiring instructions for details. Be sure to follow the N.C. directions. Some devices may work on different monitoring interfaces as well as the N.C..

Should there be a need for more than one entrapment protection device for each direction, a multi-input module from Miller Edge Model: MIM-62 (not included) may be used.



# THREE BUTTON STATION SYSTEM

See push button connections below.

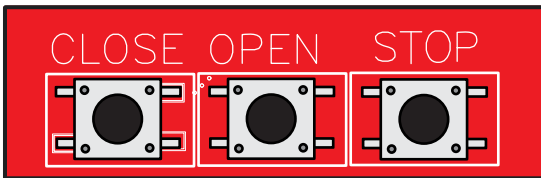

A three button station was integrated on the board to make adjustments easier when setting limit switches and adjusting ERDs.

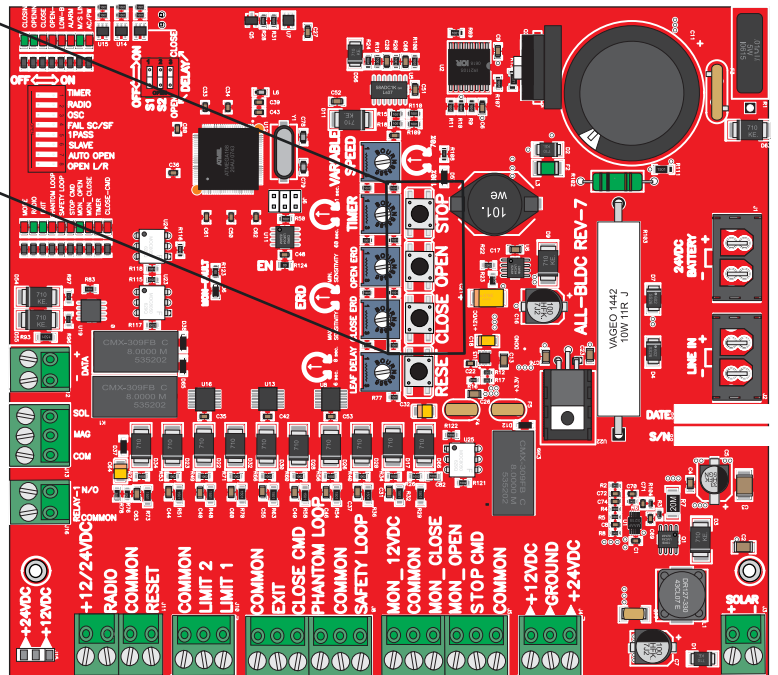

Connect the **COMMON** from all the push buttons to **COMMON** input on the board.

Connect **OPEN** push button **N.O.** contact to **EXIT** input on the board.

Connect **CLOSE** push button **N.O.** contact to **3BT** input on the board.

Connect **STOP** push button **N.C.** Contact to **STOP CMD** input on the board and remove **STOP CMD** jumper.

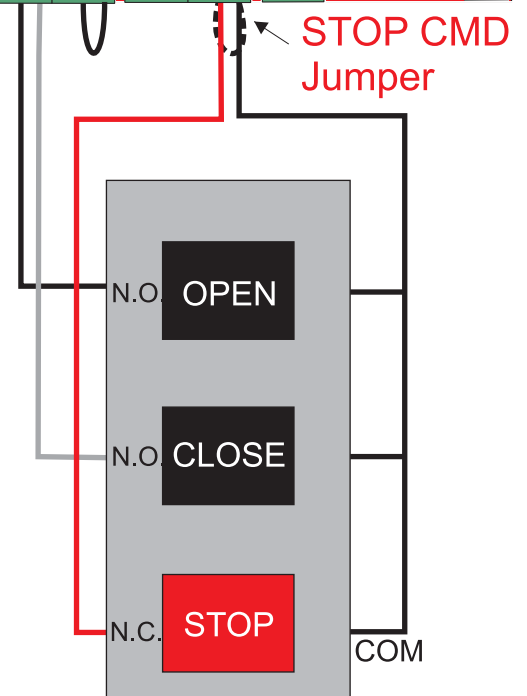

# MAGNETIC/SOLENOID LOCK CONNECTIONS

Magnetic lock installation requires a step down transformer with appropriate voltage for the specific lock accessory. Operator will provide a 120VAC outlet for the step down transformer.

**Connections:** Plug the lock device transformer to the 120VAC outlet plug.

**For Magnetic lock:** Connect one wire from transformer directly to one wire of the magnetic lock, the other wire from transformer will be connected to the relay plug **COM** input and the **MAG** relay output connects to the other wire of the magnetic lock. See illustration below.

**For Solenoid lock:** Connect one wire from transformer directly to one wire of the solenoid lock, connect the other wire from transformer to the relay plug **COM** input and the **SOL** relay output connects to the other wire of the solenoid lock. See illustration below.

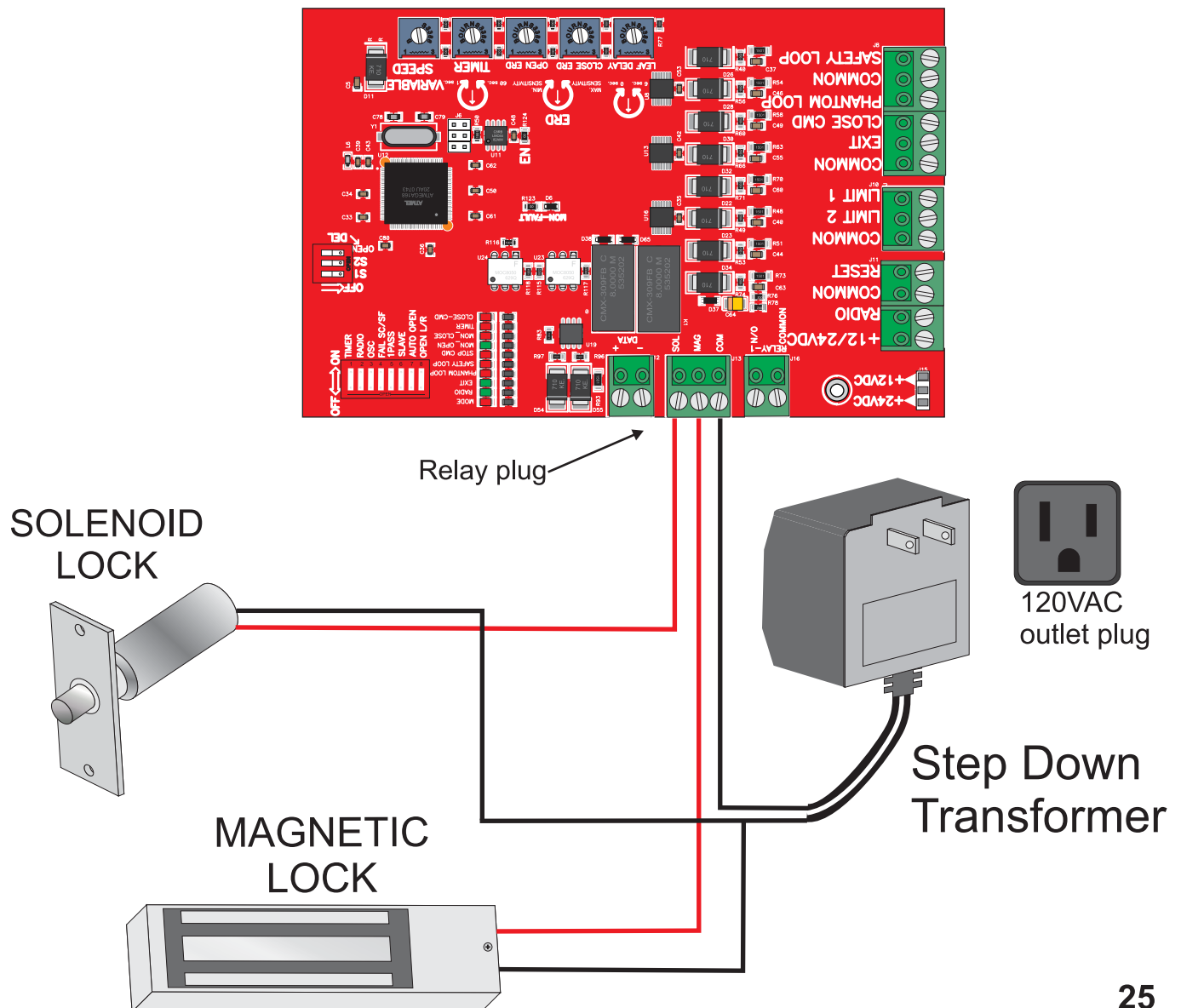

# MASTER/SLAVE CONNECTION

Before connecting master/slave gate operators together, test and adjust the limit switches and the ERDs for each operator as “stand alone” machines.

All accessories must be installed on the master board, no exception.

See page 32 for dip switch settings.

Use a two wire **shielded cable** and run it through a UL listed conduit for master/slave connection. Follow the wiring diagram as shown below.

Master Board

Slave Board

+.....Positive to Positive.....+

-.....Negative to Negative.....-

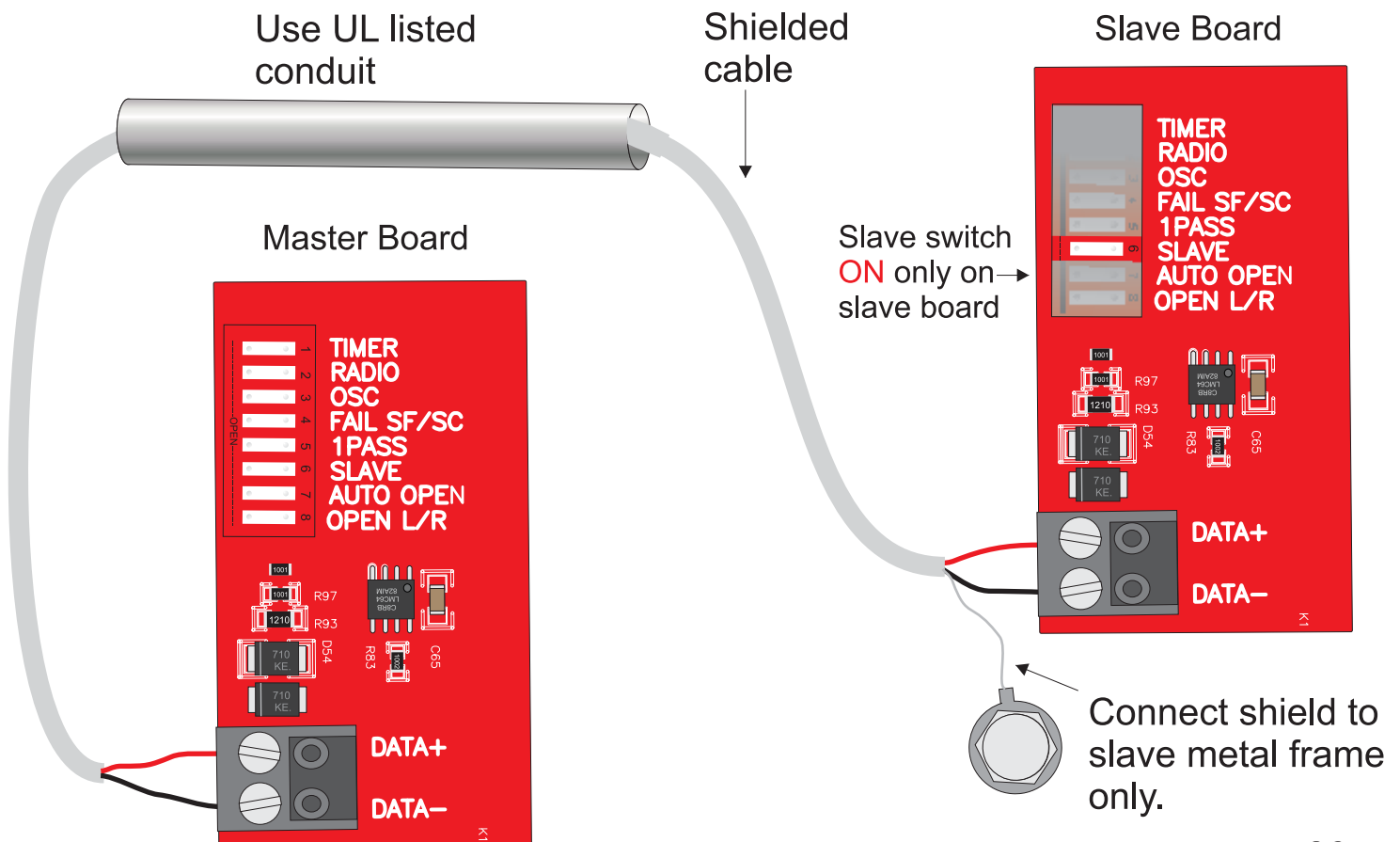

# RADIO RECEIVER CONNECTIONS

**4 wire receiver:** connect the two relay wires to 1 & 2 terminals. Black **negative** wire to terminal 1 and Red **positive** wire to terminal 3 on receiver strip outside control box as shown below.

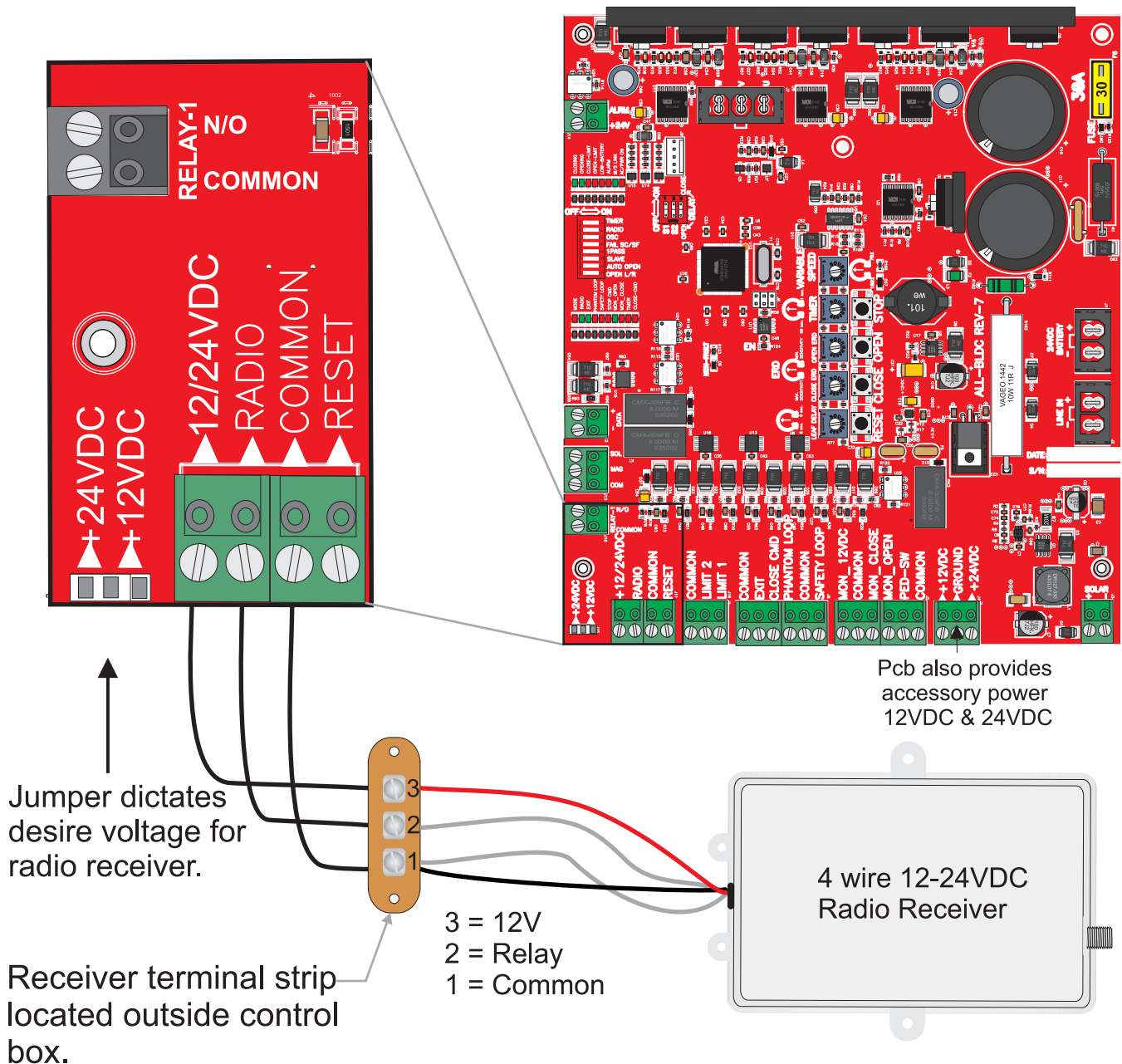



# TIMER ADJUSTMENT

TIMER ON: Timer to close, can be set from 1 to 60 seconds.

TIMER OFF: Gate operation is push button to open, push button to close.

TO OVERRIDE THE TIMER: Turn the RADIO switch to the "ON" position. This will allow the radio receiver to close the gate before the timer.

## TIMER ADJUSTMENT



Turn potentiometer counter clockwise for more time.



Turn potentiometer counter clockwise for less time.

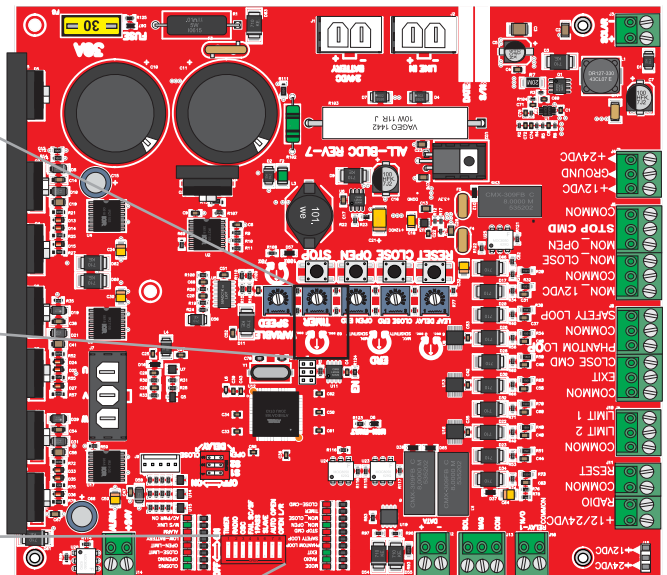
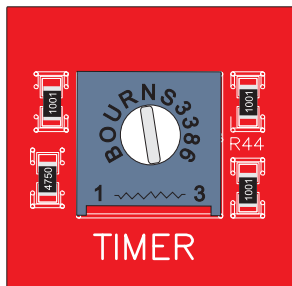

TIMER "ON" to activate the timer

RADIO "ON" = Allows the transmitter to close the gate before the timer.

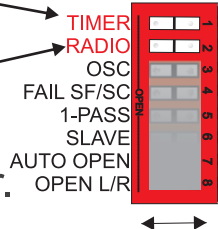



# PROGRAMMABLE RELAY & LEAF DELAY

The board model **ALL-BLDC REV 7** includes a programmable relay with four different configurations.

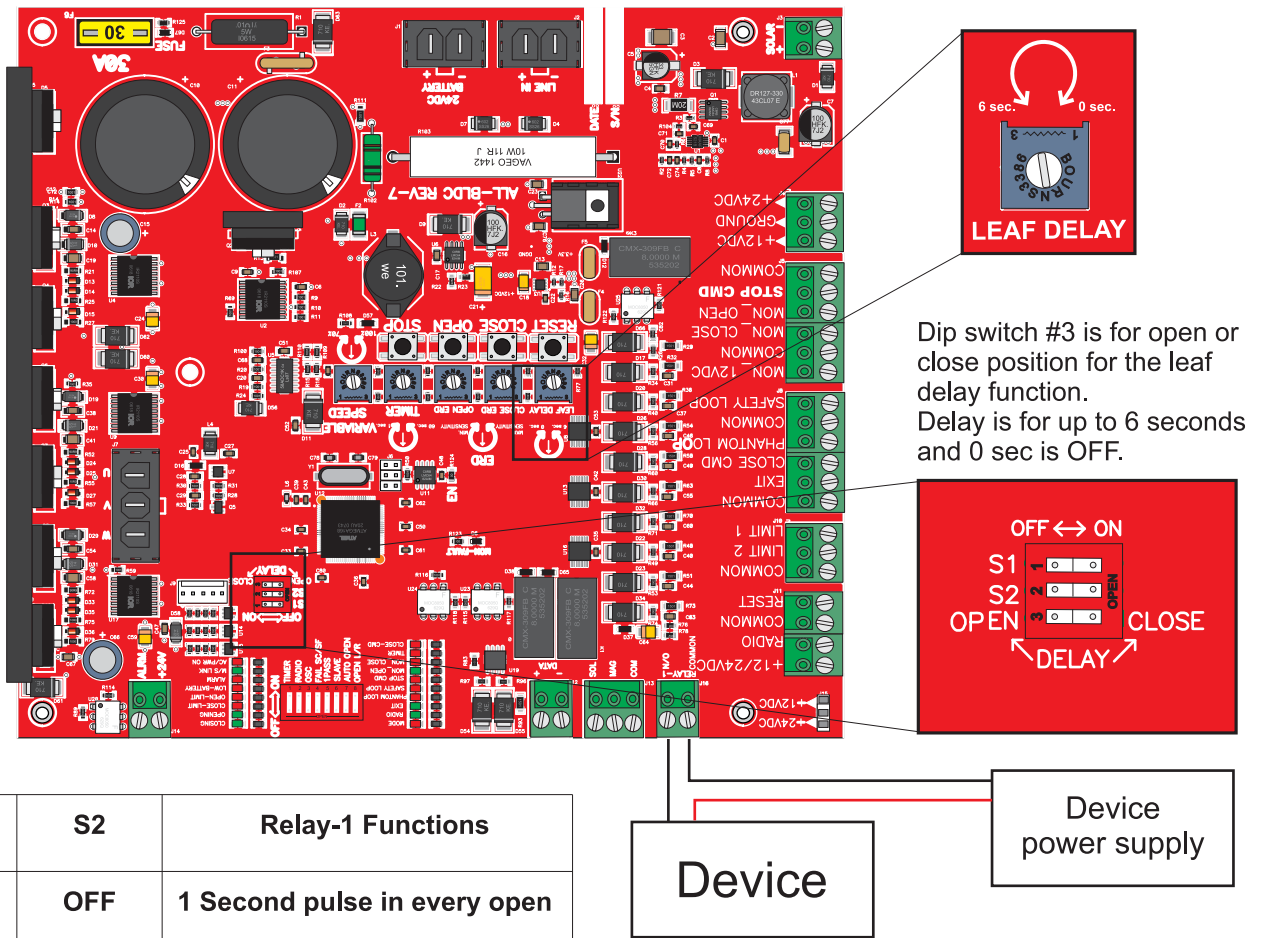

Dip switch #3 is for open or close position for the leaf delay function. Delay is for up to 6 seconds and 0 sec is OFF.

S1	S2	Relay-1 Functions
OFF	OFF	1 Second pulse in every open
ON	OFF	On when gate is in motion
OFF	ON	Alarm system output
ON	ON	On when gate not fully closed

The 1 second pulse is normally used for a cycle counter.  
 The “On” when gate is in motion is used for an audible alarm or a strobe light to warn when gate is in motion.  
 The “Alarm System” output will activate the relay whenever the gate is forced open (without access device).  
 The last function is for an indicator. It activates the relay when gate is not fully closed.



# VARIABLE SPEED CONTROL

The board model **ALL-BLDC REV 7** includes a variable speed control pot.

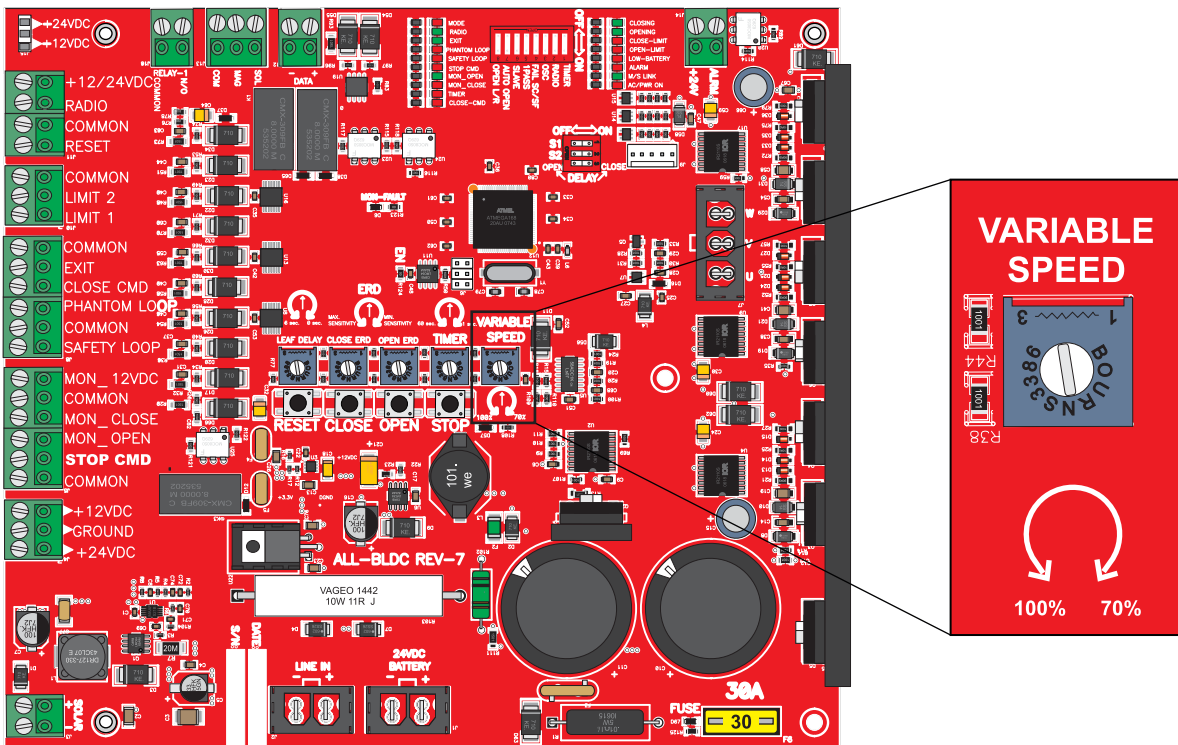

On Swingers: As the gate length exceeds 15 feet, the speed at the tip of the gate increases Gradually. The variable TIMER SPEED is used to slow down the gate operator and have a smooth, more reliable and safe operation.

Use the pot adjustment to fine tune the speed as you desire. Clockwise is slower and counter clockwise is faster.

100% = Full counter clockwise

70% = Full Clockwise

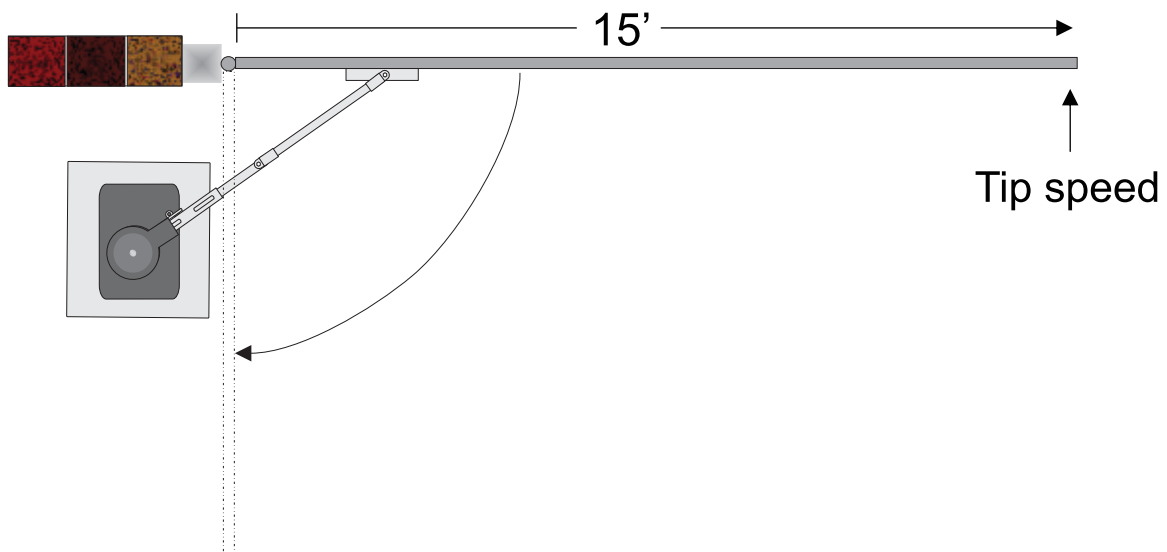

# DIP SWITCH FUNCTIONS

**NOTE:** Any changes to dip switches while power is **ON** requires you to reset the processor in order for board to read the change.

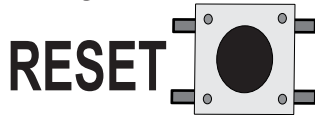

**RESET**

AUTO OPEN  
OPEN L/R

TIMER  
RADIO  
OSC  
FAIL SF/SC  
1-PASS  
SLAVE

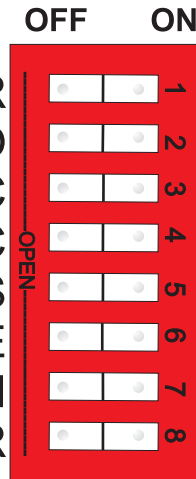

## TIMER

**TIMER** switch “**ON**” activates the **TIMER**. See page 29 for details

## RADIO

**RADIO** switch “**ON**” allows the radio receiver to override the timer. See page 29 for details.

## OSC

**OSC** switch **ON** allows the radio receiver to stop and reverse the gate in any direction. During a cycle the first signal stops gate a second signal reverses gate.

## FAIL SF/SC

This is to set the operator as fail-safe or fail secure. **ON** for **Fail-safe**: on power failure, board will monitor battery voltage to make sure gate opens before battery drains out completely. **OFF** for **Fail-secure**: on power failure gate will run until battery is low and stay close.

## 1-PASS

This is a true one pass, anti-tailgating feature. This feature may only be used with safety loops. With this switch in the “**ON**” position, the gate will open until one car passes the safety loops then it will stop and close. If a second car pulls on the loop the gate will stop the car must then back off the loop before the gate will close.

## SLAVE

This feature is used on master/slave setups. Set slave switch “**ON**” on slave machine, all other switches “**OFF**”. Set slave switch to the “**OFF**” position on master machine. Set other function switches on master machine as desired. See page 26 for more details on master/slave connections and settings.

## AUTO OPEN

This feature is to automatic open the gate on power interruption. It is a very particular feature used in areas where the fire department requires the gate to open automatically after a power outage. Set this dip switch “**ON**” when this feature is desire.

## OPEN L/R

This feature is to set the direction the operator will open. See page 16 for details.

# EMERGENCY RELEASE

## For **SW-350DC**

### Procedures to release gate:

1. Turn power OFF.
2. Push pedal down & move pedal slightly to the right to hold pedal down in position.
3. Push gate open.

See page 11 for emergency release of SW-300 Operator.



# SOLAR PANEL CONNECTION

The solar panel input will take a 12VDC panel 40W minimum. The charging circuit is limited by 1 Amp max.

When using 24VDC panel up to 40W connect straight into the **LINE IN** input.

**NOTE:** For information on what solar panel to use on any other type of installation call ALL O MATIC for Assistance.

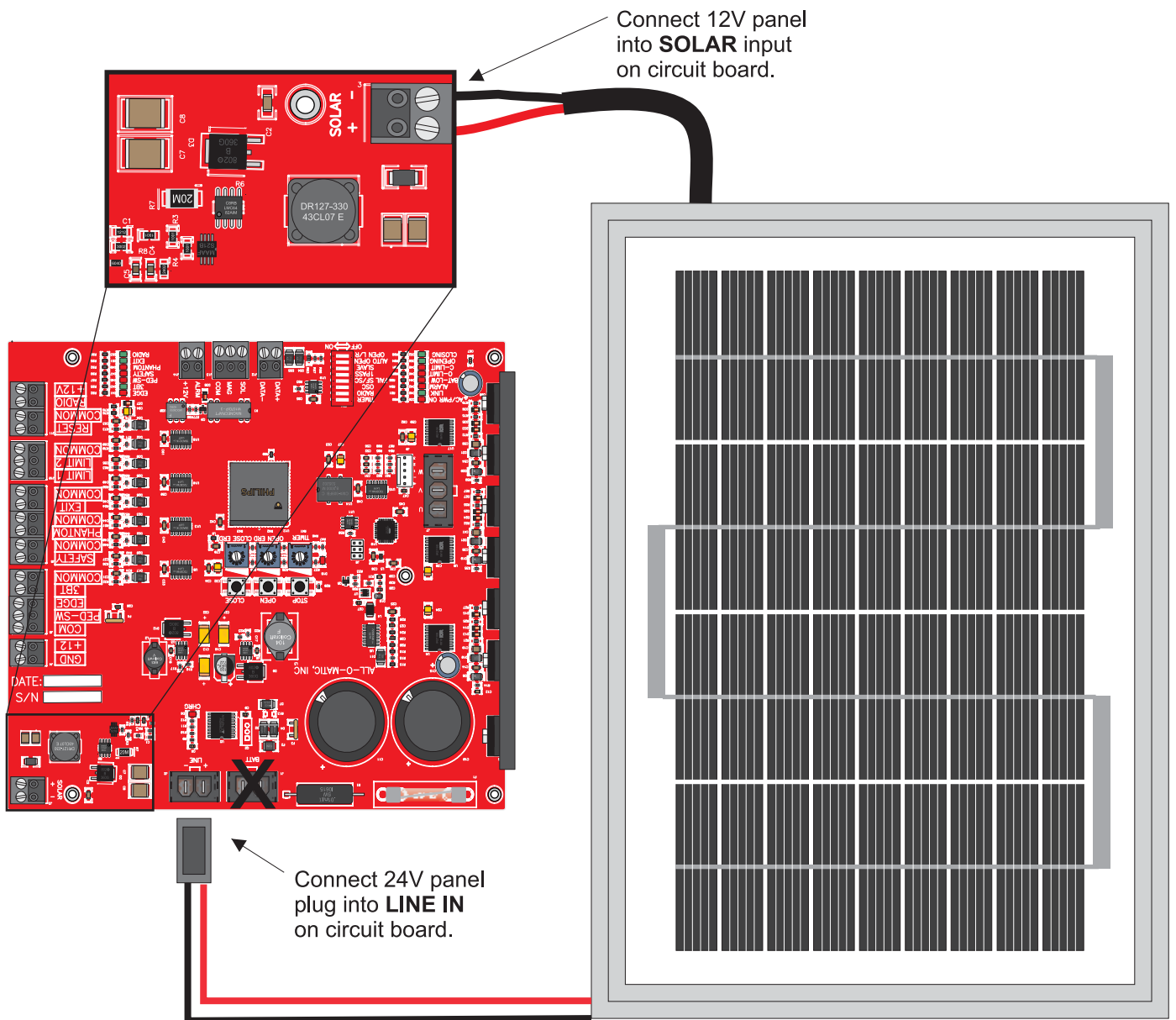

# EXTERNAL SOLAR SYSTEM INSTALLATION

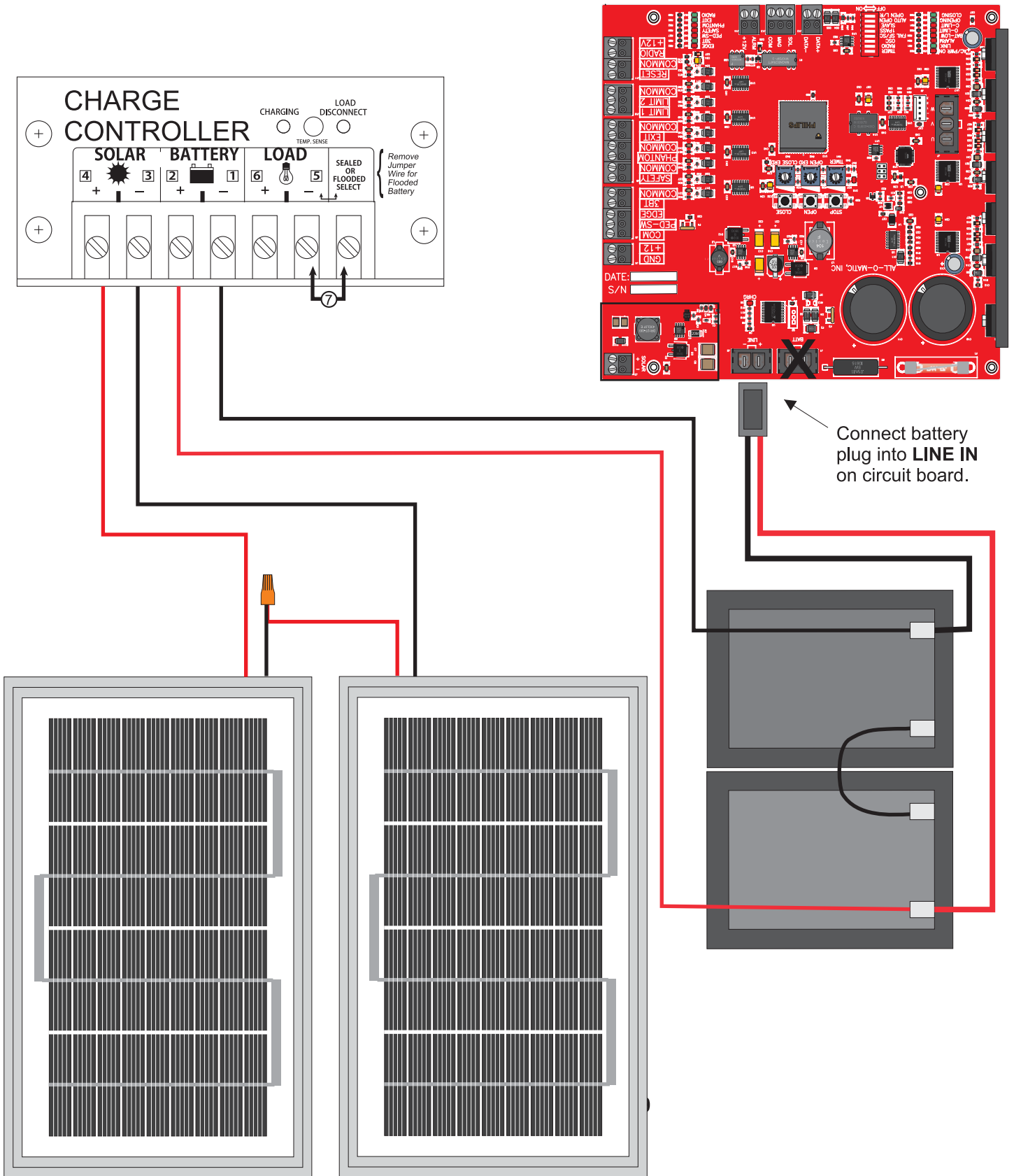

# LED DIAGNOSTICS

**AC/PWR ON:** Will be lit when AC power is ON.

**M/S LINK:** Will be lit when master/slave communication is active.

**ALARM:** Two states.

1st state: LED will blink(horn will beep also) every 30 seconds when battery is low, bad or disconnected.

2nd state: LED will turn on for 5 minutes when operator goes on shut down mode do to the gate hitting an obstruction(E.R.D.). Also, the horn will go off for 5 minutes.

**LOW BATTERY:** LED will be on solid when battery is low.

**MODE:** Two states.

1st state: LED will blink slow(about every 2 seconds) when an overload occurs(over current).

2nd state: Will blink fast(abouty every 1/2 second) when gate is jammed or motor sensors Are not responding or disconnected.

**OPEN-LIMIT:** LED will be on while limit nut is against open limit switch.

**CLOSE-LIMIT:** LED will be on while limit nut is against close limit switch.

**OPENING:** LED will be on while operator is in the open cycle(running open).

**CLOSING:** LED will be on while operator is in the close cycle(running close).

**RADIO:** LED will turn on while radio input is activated(closed circuit to COMMON).

**EXIT:** LED will turn on while EXIT input is activated(closed circuit to COMMON).

**PHANTOM:** LED will turn on while PHANTOM input is activated(closed circuit to COMMON).

**SAFETY:** LED will turn on while SAFETY input is activated(circuit is open from COMMON).

**STOP CMD:** LED will turn on while STOP CMD input is activated(circuit is open from COMMON).

**CLOSE CMD:** LED will turn on while CLOSE CMD input is activated(closed circuit to COMMON).

**MON\_OPEN:** LED will turn on while MON\_OPEN input is activated(open circuit to COMMON) or when a device is not intalled.

**MON\_CLOSE:** LED will turn on while MON\_CLOSE input is activated (open circuit to COMMON) or when a device is not installed.

**MON-FAULT:** LED will turn on when a entrapment device (MON\_OPEN or MON\_CLOSE) is not installed or a fault condition has been detected.

**TIMER LED:** LED will blink when timer is counting (on the open position only).

# SWINGER ARM PARTS

## ROUND ARM

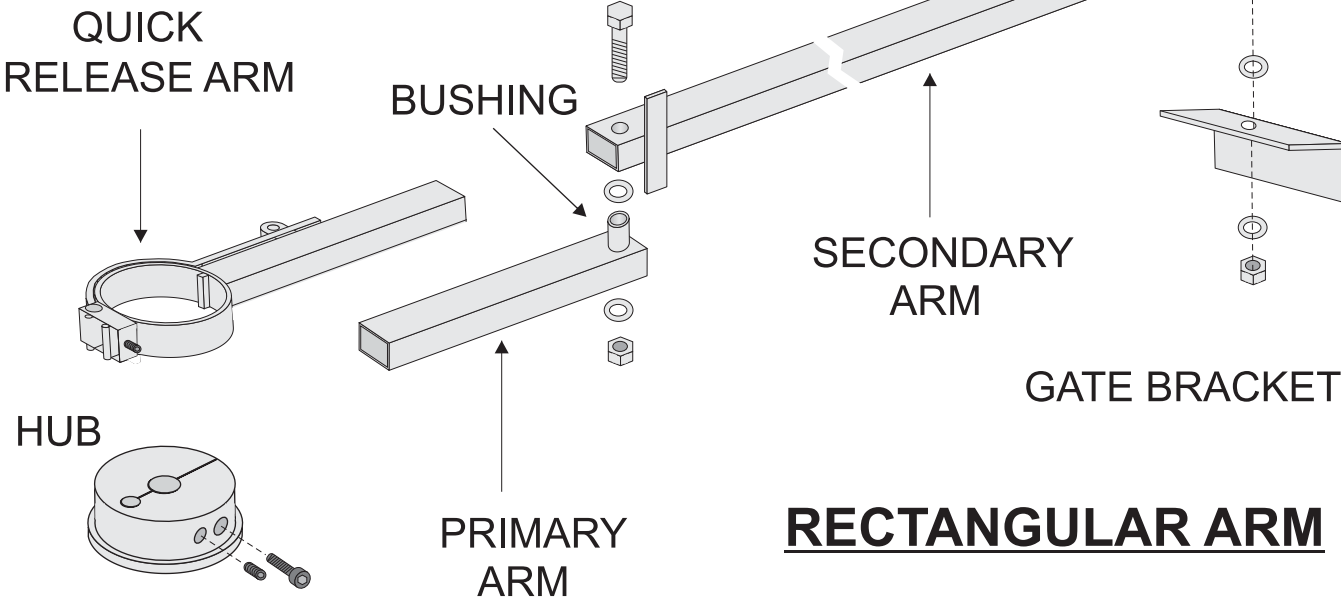
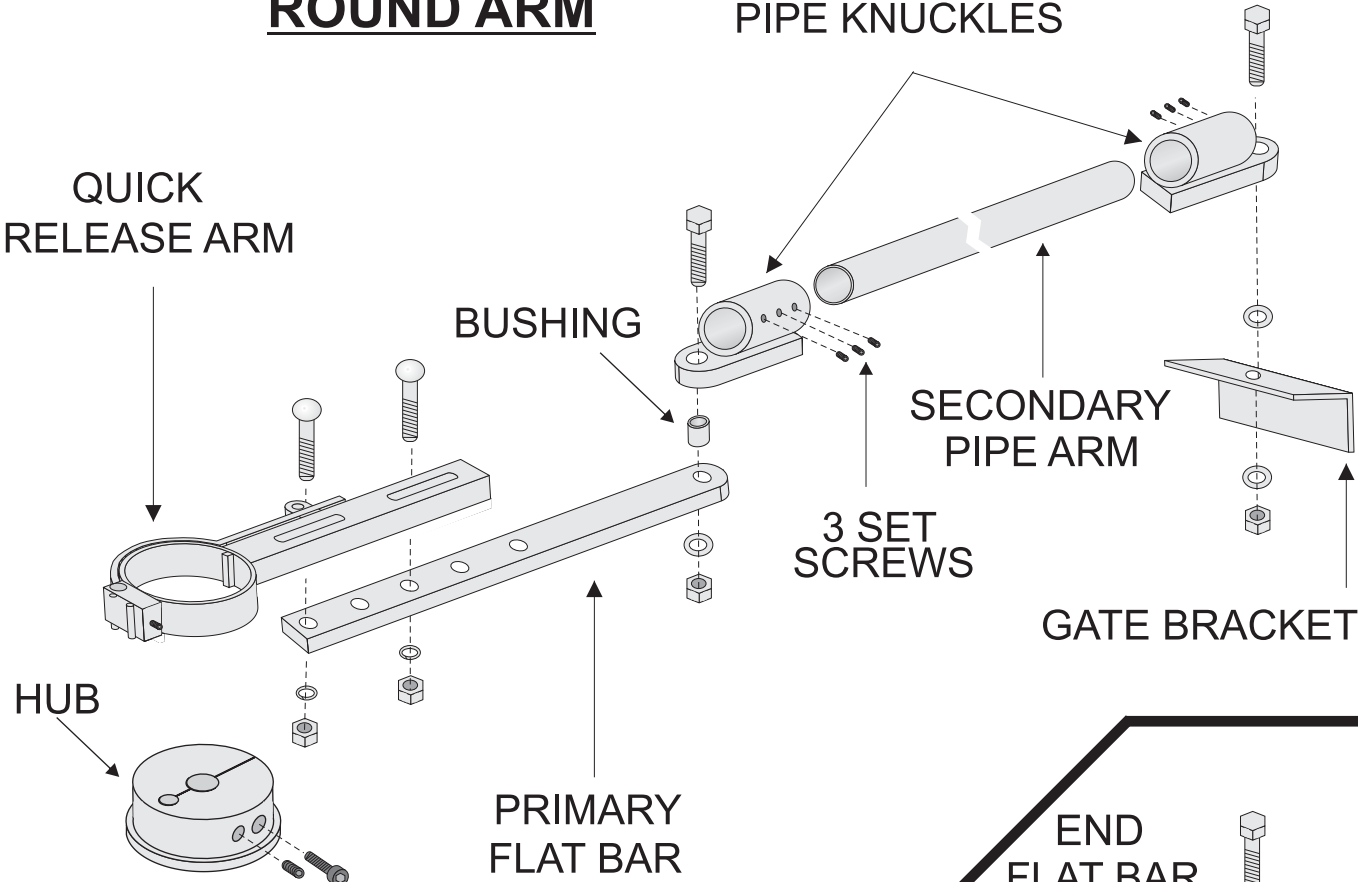



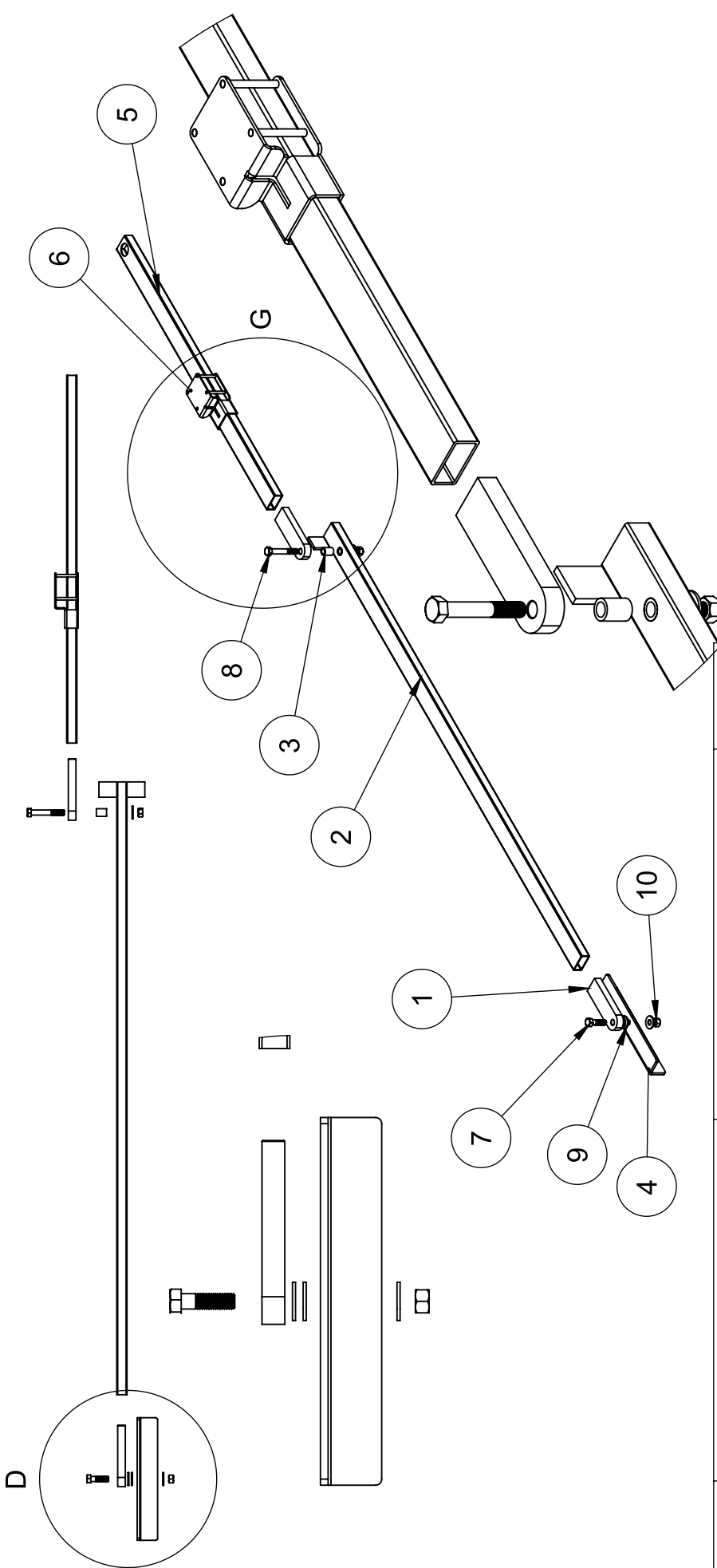

ITEM NO.	PART NUMBER	DESCRIPTION	QTY.
1	SAB-300RR	SW Arm Connecting Bar	2
2	SSA-325	SW Secondary Arm	1
3	SAS-325	SW Arm Spacer	1
4	SGB-325	SW-Gate Bracket	1
5	SPA-325	Primary arm	1
6	SQR-325	Quick Release	1
7	1/2-13 X 13/4 Hex bolt	Gate bracket Pivot bolt	1
8	1/2-13 X 3 1/4" Hex Bolt	Arm Center Pivot Bolt	1
9	1/2 Flat washer	Flat washer	4
10	1/2-13 Nylon Lock Nut	Pivot Lock nut	2

TITLE:

# SW-325DC Arm kit

SIZE DWG. NO. REV

**A**

SCALE: 1:5WEIGHT: SHEET 1 OF 1