

# Installation Guide

Avigilon™ H4 HD Dome Camera Models:

H4A-DO1(-B), H4A-DO1-IR(-B), H4A-DO2(-B), H4A-G-DO1-IR(-B)

# Important Safety Information

This manual provides installation and operation information and precautions for the use of this device. Incorrect installation could cause an unexpected fault. Before installing this equipment read this manual carefully. Please provide this manual to the owner of the equipment for future reference.



This Warning symbol indicates the presence of dangerous voltage within and outside the product enclosure that may result in a risk of electric shock, serious injury or death to persons if proper precautions are not followed.



This Caution symbol alerts the user to the presence of hazards that may cause minor or moderate injury to persons, damage to property or damage to the product itself if proper precautions are not followed.



**WARNING** — Failure to observe the following instructions may result in severe injury or death.

- Installation must be performed by qualified personnel only, and must conform to all local codes.
- This product is intended to be supplied by a UL Listed Power Unit marked “Class 2” or “LPS” or “Limited Power Source” with output rated 12 VDC or 24 VAC, 7 W min. (9 W min. for -IR model) or Power over Ethernet (PoE), rated 48 VDC, 7 W min (9 W min. for -IR model).
- Any external power supply connected to this product may only be connected to another Avigilon product of the same model series. External power connections must be properly insulated.
- Do not connect directly to mains power for any reason.



**CAUTION** — Failure to observe the following instructions may result in injury to persons or damage to the device.

- Do not expose the camera directly to high levels of x-ray, laser, or UV radiation. Direct exposure may cause permanent damage to the image sensor.
- Do not install near any heat sources such as radiators, heat registers, stoves, or other sources of heat.
- Do not subject the device cables to excessive stress, heavy loads or pinching.
- Do not open or disassemble the device. There are no user serviceable parts.
- Refer all device servicing to qualified personnel. Servicing may be required when the device has been damaged (such as from a liquid spill or fallen objects), has been exposed to rain or moisture, does not operate normally, or has been dropped.
- Do not use strong or abrasive detergents when cleaning the device body.
- Use only accessories recommended by Avigilon.

# Regulatory Notices

This device complies with part 15 of the FCC Rules. Operation is subject to the following two conditions: (1) this device may not cause harmful interference, and (2) this device must accept any interference received, including interference that may cause undesired operation.

This Class B digital apparatus complies with Canadian ICES-003.

This equipment has been tested and found to comply with the limits for a Class B digital device, pursuant to Part 15 of the FCC rules. These limits are designed to provide reasonable protection against harmful interference in a residential installation. This equipment generates, uses and can radiate radio frequency energy and, if not installed and used in accordance with the instructions, may cause harmful interference to radio communications. However, there is no guarantee that interference will not occur in a particular installation. If this equipment does cause harmful interference to radio or television reception, which can be determined by turning the equipment off and on, the user is encouraged to try to correct the interference by one or more of the following measures:

- Reorient or relocate the receiving antenna.
- Increase the separation between the equipment and the receiver.
- Connect the equipment into an outlet on a circuit different from that to which the receiver is connected.
- Consult the dealer or an experienced radio/TV technician for help.

Changes or modifications made to this equipment not expressly approved by Avigilon Corporation or parties authorized by Avigilon Corporation could void the user's authority to operate this equipment.

# Disposal and Recycling Information

When this product has reached the end of its useful life, please dispose of it according to your local environmental laws and guidelines.

Risk of fire, explosion, and burns. Do not disassemble, crush, heat above 100 °C (212 °F), or incinerate.

## European Union:



This symbol means that according to local laws and regulations your product should be disposed of separately from household waste. When this product reaches its end of life, take it to a collection point designated by local authorities. Some collection points accept products for free. The separate collection and recycling of your product at the time of disposal will help conserve natural resources and ensure that it is recycled in a manner that protects human health and the environment.

# Legal Notices

© 2019, Avigilon Corporation. All rights reserved. AVIGILON, the AVIGILON logo, AVIGILON CONTROL CENTER, and ACC are trademarks of Avigilon Corporation. ONVIF is a trademark of Onvif, Inc. Other names or logos mentioned herein may be the trademarks of their respective owners. The absence of the symbols ™ and ® in proximity to each trademark in this document or at all is not a disclaimer of ownership of the related trademark. Avigilon Corporation protects its innovations with patents issued in the United States of America and other jurisdictions worldwide (see [avigilon.com/patents](http://avigilon.com/patents)). Unless stated explicitly and in writing, no license is granted with respect to any copyright, industrial design, trademark, patent or other intellectual property rights of Avigilon Corporation or its licensors.

## Disclaimer

This document has been compiled and published using product descriptions and specifications available at the time of publication. The contents of this document and the specifications of the products discussed herein are subject to change without notice. Avigilon Corporation reserves the right to make any such changes without notice. Neither Avigilon Corporation nor any of its affiliated companies: (1) guarantees the completeness or accuracy of the information contained in this document; or (2) is responsible for your use of, or reliance on, the information. Avigilon Corporation shall not be responsible for any losses or damages (including consequential damages) caused by reliance on the information presented herein.

Avigilon Corporation  
avigilon.com

PDF-H4ADO-A(-B)

Revision: 5 - EN

20191224

# Table of Contents

Overview .....	1
Cover View .....	1
Top View .....	2
Wall Plate View .....	3
Front View .....	4
Rear View .....	5
IR View .....	6
Installation .....	7
Required Tools and Materials .....	7
Camera Package Contents .....	7
Installation Steps .....	7
Removing the Dome Cover .....	7
Mounting and Aiming Video Analytics Cameras .....	7
Inserting Cables through the Sealing Grommet .....	8
Mounting the Dome Camera .....	8
Mounting the Dome Camera Using the Bottom Cable Entry Hole .....	8
Mounting the Dome Camera Using the Side Cable Entry Hole .....	9
Mounting the Dome Camera to an Electrical Box .....	12
Connecting Cables .....	13
Initializing a Camera Username and Password .....	13
(Optional) Using the USB Wi-Fi Adapter .....	14
Assigning an IP Address .....	15
Accessing the Live Video Stream .....	15
Aiming the Dome Camera .....	16
(Optional) Configuring SD Card Storage .....	16
Setting the Time .....	16
Installing the Dome Cover .....	17
Zooming and Focusing the Dome Camera .....	18
Configuring the Camera .....	18
For More Information .....	18
Cable Connections .....	19
Connecting External Power .....	19
Connecting to External Devices .....	19
Connecting to Microphones, Speakers, and Video Monitors .....	20

Connection Status LED Indicator .....	22
Resetting to Factory Default Settings .....	23
Setting the IP Address Using the ARP/Ping Method .....	24
Cleaning .....	25
Dome Bubble .....	25
Body .....	25
Limited Warranty and Technical Support .....	26

# Overview

## Cover View

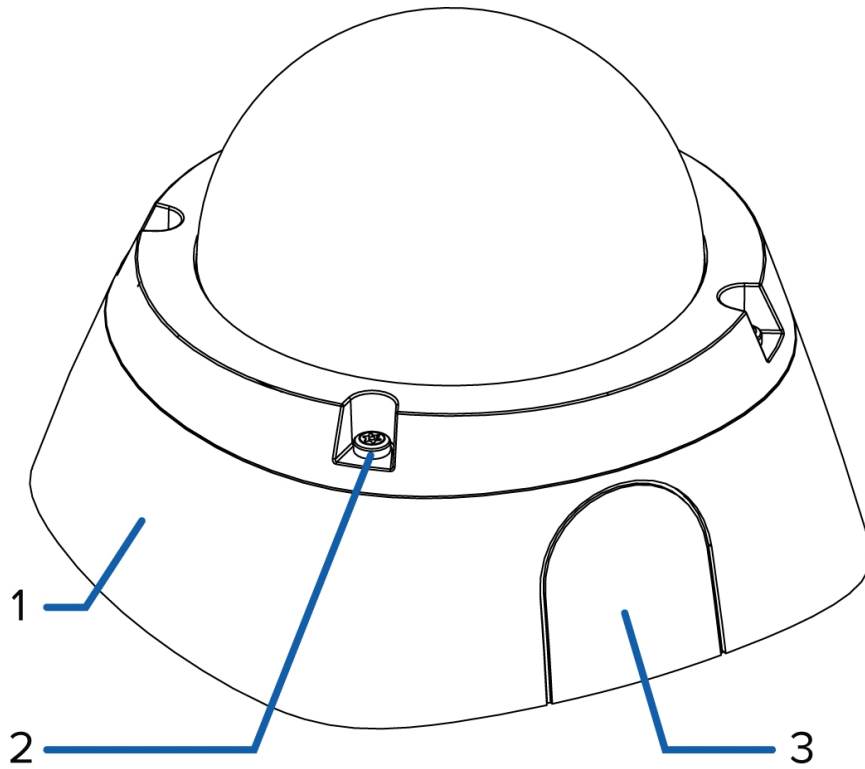

1. **Dome cover**

Vandal resistant dome cover.

2. **Tamper resistant screws**

Star-shaped captive screws to fix the dome cover to the base.

3. **Side cable entry cover**

Covers the side cable entry hole.

## Top View

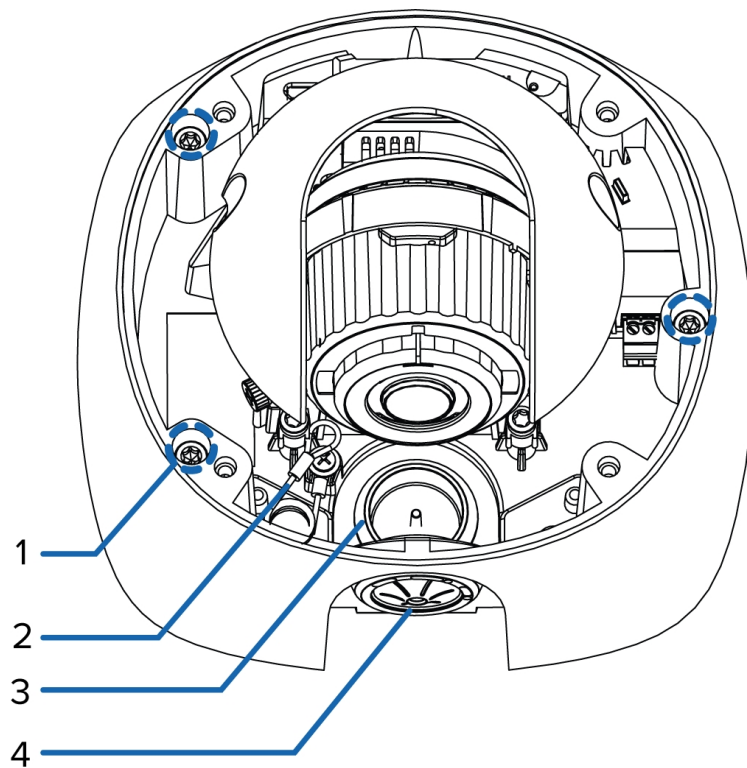

1. **Wall plate mounting screws**

Screws for mounting the camera to the wall plate.

2. **Lanyard**

Connects to a lanyard hook on the cover.

3. **Bottom cable entry hole**

A bottom entry hole for the cables required for camera operation.

4. **Side cable entry hole**

A side entry hole for the cables required for camera operation.



# Wall Plate View

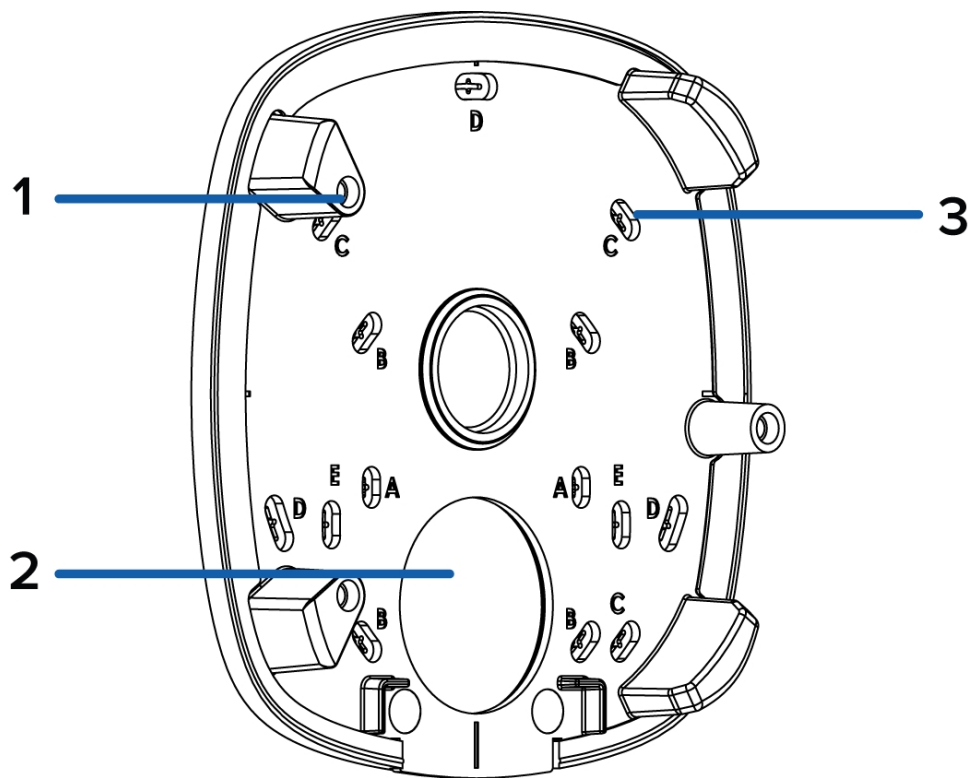

**1. Camera mounts**

Points for mounting the camera body to the wall plate.

**2. Cable entry hole**

An entry hole for the cables required for camera operation.

**3. Mounting holes**

Holes for mounting the wall plate to the following:

- A. UK standard single gang box
- B. Octagon gang box
- C. 4" gang box
- D. Mounting surface
- E. US standard single gang box

## Front View

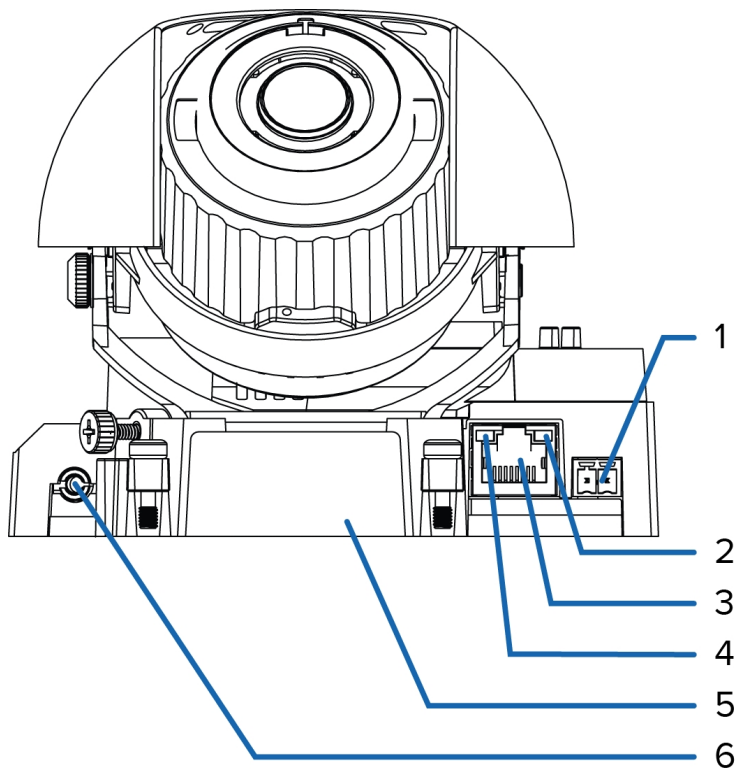

1. **Power connector block**

Accepts a terminal block with either an AC or DC power connection. DC input can be either polarity. Only required when Power over Ethernet is not available.

2. **Link LED indicator**

Indicates if there is an active connection in the Ethernet port.

3. **Ethernet port**

Accepts an Ethernet connection to a network. Server communication and image data transmission occurs over this connection. Also receives power when it is connected to a network that provides Power over Ethernet.

4. **Connection status LED indicator**

Provides information about device operation. For more information, see *Connection Status LED Indicator* on page 22.

5. **Serial number tag**

Device information, product serial number and part number label.

6. **Audio/video connector**

Accepts a mini-jack connector (3.5 mm).

## Rear View

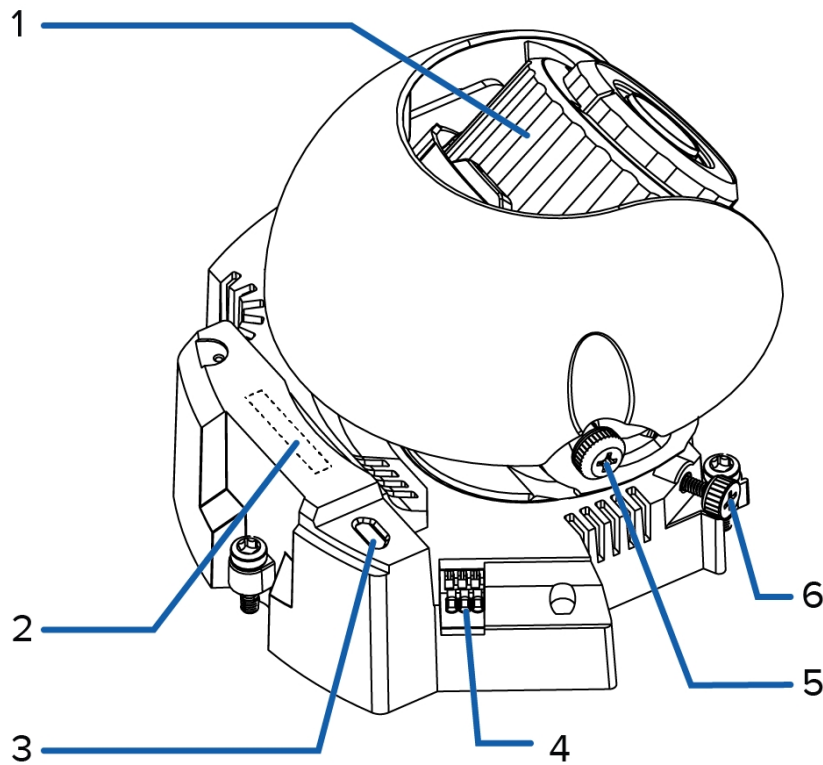

1. **Azimuth control**

Provides control of the image angle.

2. **SD card slot**

Accepts an SD card for onboard storage.

Not available on H4 Edge Solution (ES) Cameras.

3. **Micro USB port**

Accepts a micro USB to USB adapter. Only required when using the Avigilon USB Wi-Fi Adapter.

4. **I/O connector block**

Provides connections to external input/output devices.

5. **Tilt lock thumb screw**

Provides a locking mechanism for the image tilt adjustment.

6. **Pan lock thumb screw**

Provides a locking mechanism for the image pan adjustment.

## IR View

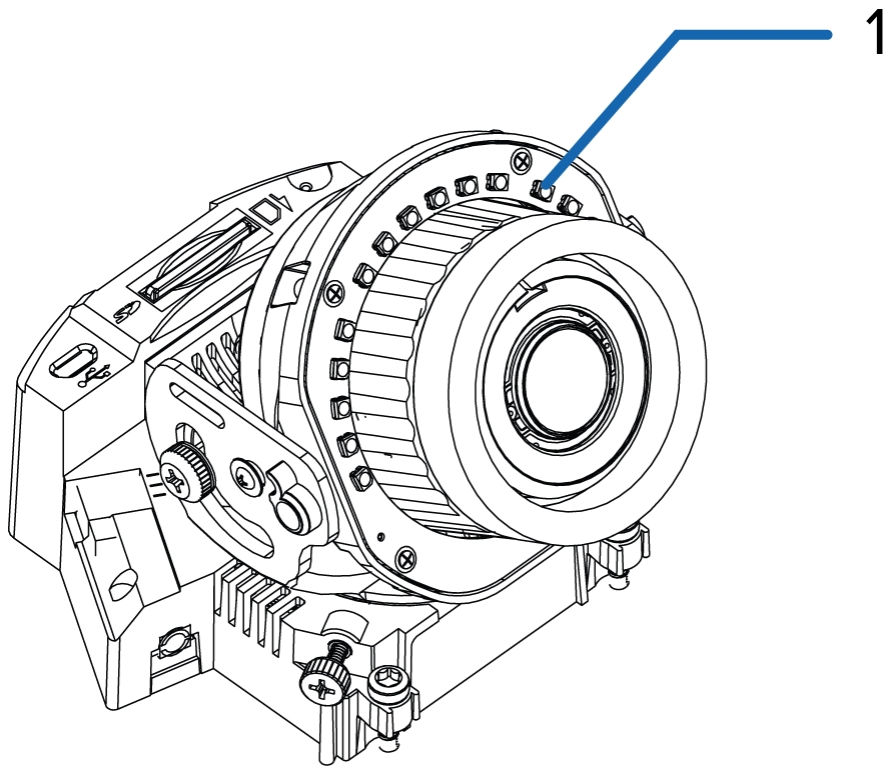

### IR Illuminator Ring

Provides scene illumination in the IR spectrum. The IR illuminator ring is not included with all models.

# Installation

## Required Tools and Materials

- Small slotted screwdriver with 5/64" or 2 mm blade width — for connecting power when not using Power over Ethernet.
- No. 2 Phillips screwdriver — for attaching camera to an electrical box or mounting surface
- T20 Pin-In star-shaped driver
- Silicone sealant

## Camera Package Contents

Ensure the package contains the following:

- Avigilon H4 HD Dome Camera
- Mounting template sticker
- RJ-45 grommet piercing cap
- Pipe grommet
- 4 screws and anchors for solid walls
- Wall plate

## Installation Steps

Complete the following sections to install the device.

### Removing the Dome Cover

Remove the dome cover by loosening the screws that fix the cover to the base. Use a T20 Pin-In star-shaped driver to loosen the screws.

**Note:** Be careful not to scratch or touch the dome bubble. The resulting marks or fingerprints may affect the overall image quality. Keep the protective covers on the outside of the dome bubble until the installation is complete.

### Mounting and Aiming Video Analytics Cameras

When installing an Avigilon video analytics camera, follow the listed mounting and aiming recommendations to maximize the camera's analytics capabilities:

- The camera should be installed above 274 cm (9').
- The camera should tilt downwards no more than 45 degrees.
- The camera image should be level with the horizon line.
- The camera should be mounted to a stable surface to minimize the physical movement of the camera after installation.

For more details, see *Designing a Site for Video Analytics*. The document is available on the Avigilon website.

## Inserting Cables through the Sealing Grommet

Unless specified otherwise, you must pull the required cables through the sealing grommet included with the camera when using a cable entry hole.

1. Remove the sealing grommet from the camera.
2. Pull the tab on the grommet to open a hole for the Ethernet cable.
3. Push an Ethernet cable through the grommet by one of the following methods:
  - a. If the Ethernet cable is uncrimped, push the cable through the grommet.
  - b. If the Ethernet cable is already crimped, place the grommet piercing cap on the Ethernet connector then push the cable through the grommet.

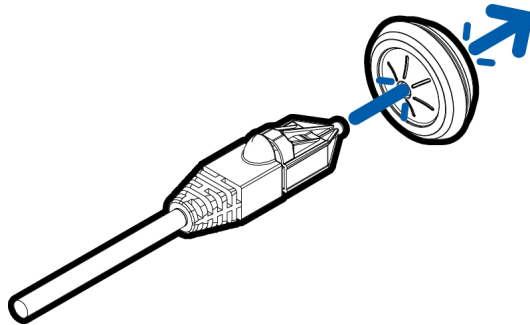

Ensure that the orientation of the cable and grommet matches the one shown in the image.

4. Push any other required cables through the grommet.

**Note:** If you will pull multiple cables through the sealing grommet, apply silicone sealant to seal any gaps in the grommet.

## Mounting the Dome Camera

### Mounting the Dome Camera Using the Bottom Cable Entry Hole

Perform the following steps if the required cables will be coming out of the mounting surface. Use this procedure on surfaces that can easily be cut, such as aluminum, and when the cables should be kept out of sight.

1. Use the mounting template to drill 3 mounting holes and one cable entry hole into the mounting surface.
2. Pull the cables through the cable entry hole in the mounting surface.
3. If a flush mount with the surface is preferred, remove the wall plate gasket.
4. Drive 3 screws to fasten the wall plate to the ceiling or wall.

**Note:** It is recommended that silicone sealant be applied around the edges of the wall plate gasket to prevent moisture from entering the mounting surface.

5. Insert the sealing grommet with the required cables pulled through into the cable entry hole on the bottom of the camera. For more information, see *Inserting Cables through the Sealing Grommet* on the previous page.
6. Mount the camera body to the wall plate with the wall plate mounting screws.

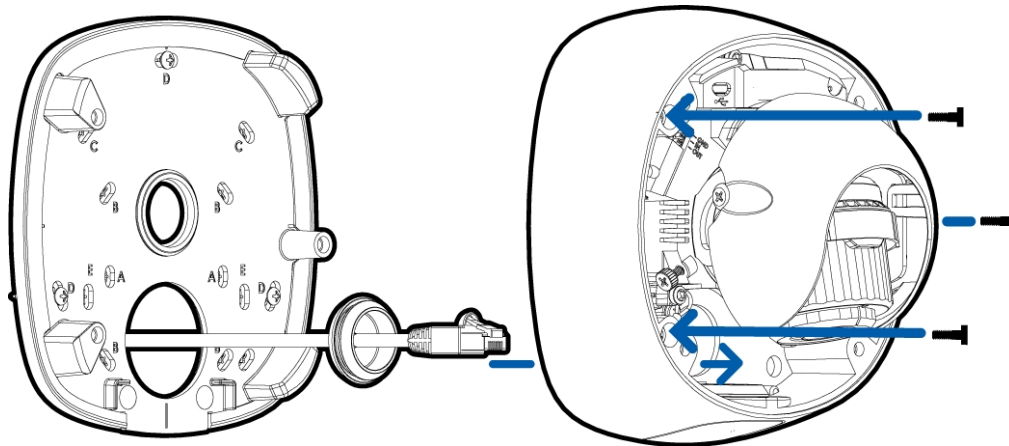

### Mounting the Dome Camera Using the Side Cable Entry Hole

Perform the following steps if you will be mounting to a surface with the required cables coming out of an external conduit pipe. Use this procedure if the mounting surface cannot be easily cut, or when cables must be brought along the outside of the mounting surface.

1. Use the mounting template to drill three mounting holes and position the conduit pipe correctly.
2. Pull the required cables through the conduit.
3. Pull the required cables through the provided pipe grommet.

**Note:** The pipe grommet only accepts uncrimped Ethernet cables.

4. Insert the pipe grommet into the conduit pipe

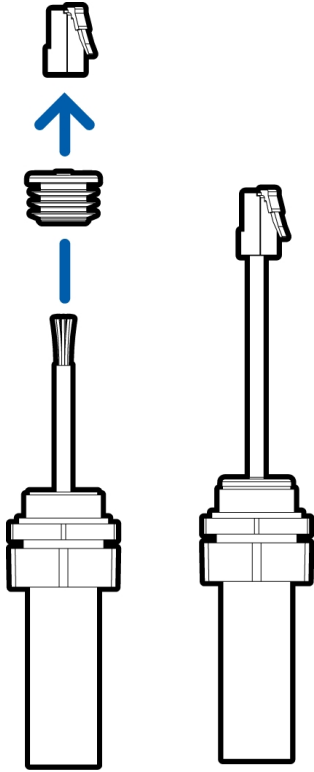

5. If a flush mount is preferred, remove the wall plate gasket.
6. Drive three screws into the mounting holes to fasten the wall plate to the mounting surface.

**Note:** It is recommended that silicone sealant be applied around the edges of the wall plate gasket to prevent moisture from entering the mounting surface.



7. Unscrew the side cable entry cover to expose the side cable entry hole.

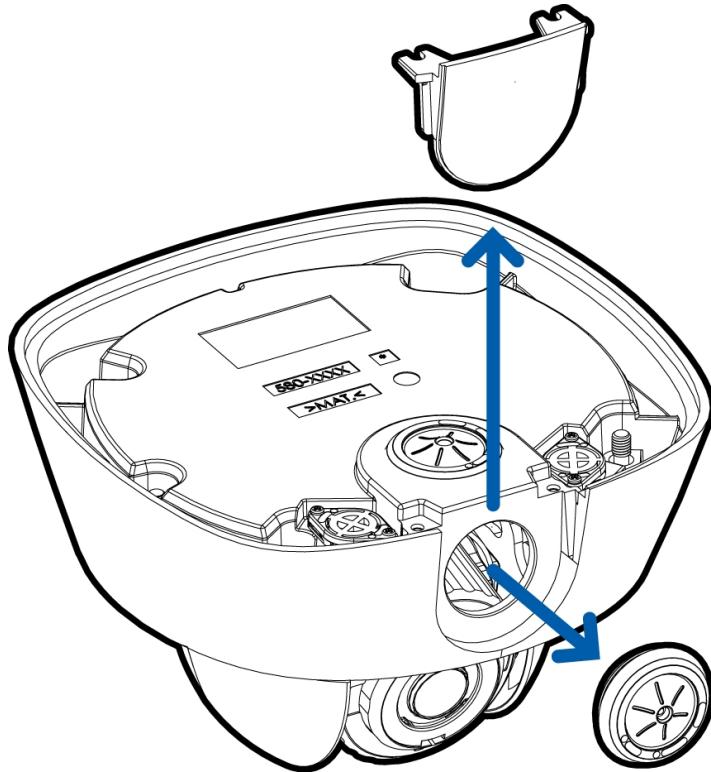

8. Remove the sealing grommet from the side cable entry hole.
9. Remove the conduit's locking ring and insert the conduit into the side cable entry hole.

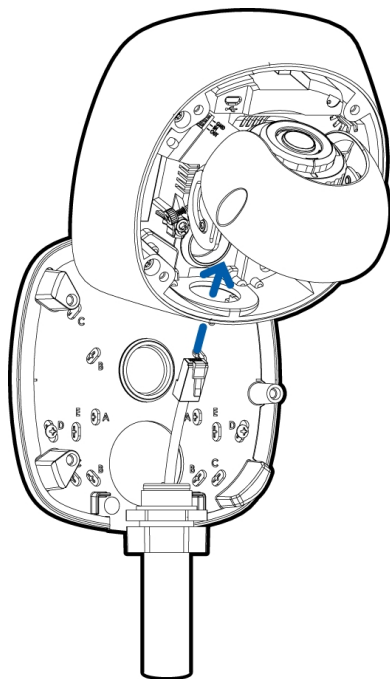

10. Fasten the camera body to the wall plate using the wall plate mounting screws.
11. Replace the locking ring to secure the conduit pipe.

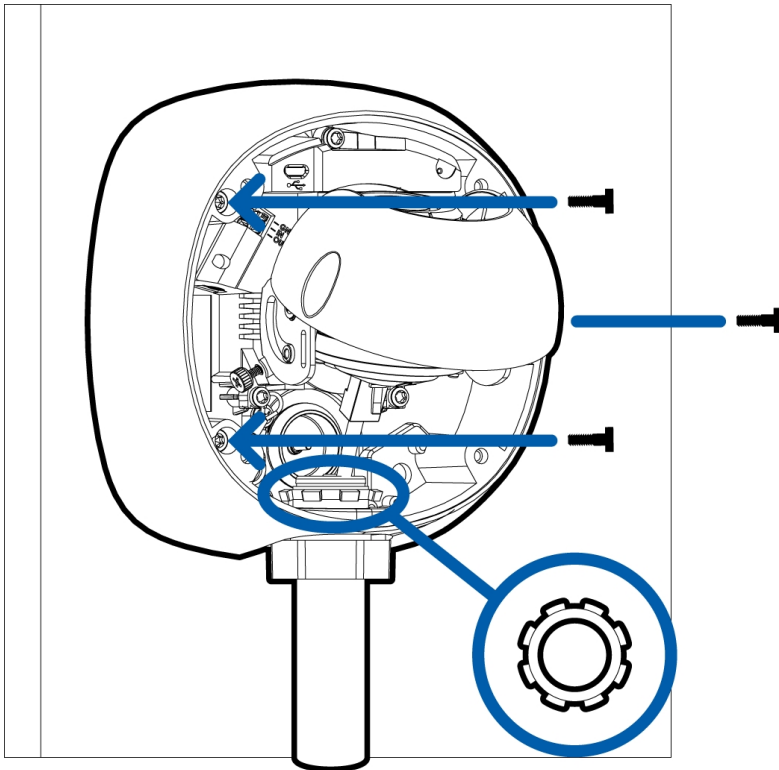

### Mounting the Dome Camera to an Electrical Box

Perform the following steps if the required electrical components and cables will be contained in an electrical gang box inside the mounting surface.

1. If a flush mount is preferred, remove the wall plate gasket.
2. Mount the wall plate to the electrical box. Use the hole configuration that matches the box:
  - A — UK standard single gang box
  - B — Octagon gang box
  - C — 4" gang box
  - E — US standard single gang box

**Note:** It is recommended that silicone sealant be applied around the edges of the wall plate gasket to prevent moisture from entering the mounting surface or electrical box.

3. Pull the required cables through the cable entry hole on the wall plate.
4. Insert the sealing grommet with the required cables pulled through into the cable entry hole on the bottom of the camera. For more information on using the sealing grommet, see *Inserting Cables*

through the Sealing Grommet on page 8.

5. Mount the camera to the wall plate using the wall plate mounting screws.

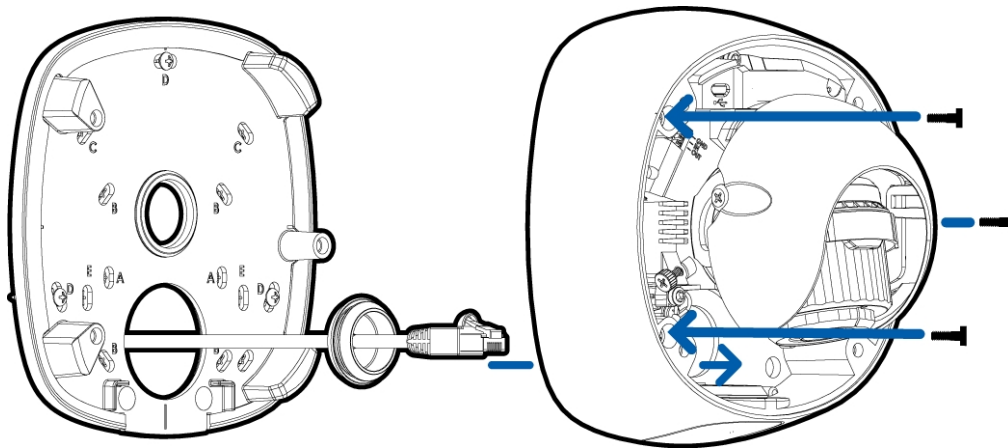

## Connecting Cables

Refer to the diagrams in the Overview section for the location of the different connectors.

1. If external input or output devices are part of the installation (for example: door contacts, relays, etc.), connect the devices to the I/O connector block.
2. If an external microphone needs to be connected to the camera, connect the device to the camera A/V connector.

For more information, see *Connecting to Microphones, Speakers, and Video Monitors* on page 20.

3. (1.0 and 2.0 megapixel models only) If an external video monitor needs to be connected to the camera, connect the device to the camera A/V connector.

For more information, see *Connecting to Microphones, Speakers, and Video Monitors* on page 20.

4. Connect a network cable to the Ethernet port (RJ-45 connector).

The Link LED indicator will turn on once a network link has been established.

5. Connect power using one of the following methods:
  - Power over Ethernet (PoE) Class 3 — If PoE is available, the LEDs will turn on.
  - External Power — Connect an external 12 V DC or 24 V AC power source to the power connector block.
6. Check that the Connection Status LED indicator indicates the correct state. For more information, see *Connection Status LED Indicator* on page 22.

## Initializing a Camera Username and Password

Cameras manufactured after January 1, 2020, do not have a default username or password and will be in a factory default state.

**Important:** You must create a user with *administrator* privileges before the camera is operational.

The first user can be created using any of the following methods:

- Camera's Web Interface: enter the camera's IP address in a web browser to access the web interface. If the camera is in the factory default state you will be redirected to the Add a new user page to create the first user. For more information, see the *Avigilon High Definition H4 and H5 IP Camera Web Interface User Guide*.
- Camera Configuration Tool version 1.4.4 or later: cameras discovered in the factory default state will be identified by . Select the **Admin Users** tab to create the first user. For more information, see the *Avigilon Camera Configuration Tool User Guide*.
- USB Wi-Fi Adapter: when connecting a camera in the factory default state, you will be redirected to the Create Administrator User page to create the first user. For more information, see *Avigilon USB Wi-Fi Adapter System User Guide*.
- Avigilon Control Center software version 7.4 or later, or version 6.14.12 or later: when connecting a camera in the factory default state, the client software will ask you to create a new user. For more information, see the *Avigilon Control Center Client User Guide*.
- Avigilon Blue service v3.0 or later: when adding a camera you will be asked to create a new user for cameras in the factory default state. For more information, see the *Avigilon Blue Subscriber or Dealer User Guides*.

**Tip:** If you are connecting your Avigilon camera to a 3rd party VMS, you will need to set up the first user through the camera's Web Interface, Camera Configuration Tool, or USB Wifi Adapter before you connect to the 3rd party VMS.

## (Optional) Using the USB Wi-Fi Adapter

If you have a USB Wi-Fi Adapter (H4-AC-WIFI), attach it to the camera's micro USB port to access the camera's mobile web interface.

After you connect to the Wi-Fi signal broadcast by the adapter, you can access the mobile web interface from any mobile device using the following address:

http://camera.lan

For more information about configuring the camera from the mobile web interface see *Avigilon USB Wi-Fi Adapter System User Guide*.

**Note:** The camera will reserve the 10.11.22.32/28 subnet for internal use while the USB Wi-Fi Adapter is plugged in.

## Assigning an IP Address

The device automatically obtains an IP address when it is connected to a network.

**Note:** If the device cannot obtain an IP address from a DHCP server, it will use Zero Configuration Networking (Zeroconf) to choose an IP address. When set using Zeroconf, the IP address is in the 169.254.0.0/16 subnet.

The IP address settings can be changed using one of the following methods:

- The mobile web interface using the USB Wifi Adapter. For more information, see *(Optional) Using the USB Wi-Fi Adapter* on the previous page.
- Device's web browser interface: `http://<camera IP address>/`.
- Network Video Management software application (for example, the Avigilon Control Center™ software).
- ARP/Ping method. For more information, see *Setting the IP Address Using the ARP/Ping Method* on page 24.

**Note:**

Depending on the manufacture date of your camera, you will have one of the two options below to log in for the first time:

- Cameras manufactured after January 1, 2020: these cameras do not have a default username or password and will be in a factory default state. **You must create a user with administrator privileges before the camera is operational.** For more information, see *Initializing a Camera Username and Password* on page 13.
- Cameras manufactured before January 1, 2020: login to the camera using the default username of `administrator` with no password. It is recommended that you change the password after your first login.

## Accessing the Live Video Stream

Live video stream can be viewed using one of the following methods:

- The mobile web interface using the USB Wifi Adapter. For more information, see *(Optional) Using the USB Wi-Fi Adapter* on the previous page.
- Web browser interface: `http://< camera IP address>/`.
- Network Video Management software application (for example, the Avigilon Control Center™ software).

**Note:**

Depending on the manufacture date of your camera, you will have one of the two options below to log in for the first time:

- Cameras manufactured after January 1, 2020: these cameras do not have a default username or password and will be in a factory default state. **You must create a user with administrator privileges before the camera is operational.** For more information, see *Initializing a Camera Username and Password* on page 13.
- Cameras manufactured before January 1, 2020: login to the camera using the default username of `administrator` with no password. It is recommended that you change the password after your first login.

## Aiming the Dome Camera

Reference the camera's live stream as you aim the camera.

1. Loosen the pan and tilt lock screws on the camera.
2. Turn the lens to the correct direction by panning and tilting the lens.
3. Tighten the pan and tilt lock screws to secure the dome camera's position.
4. Rotate the azimuth control ring to set the image to the correct angle.
5. In the camera web browser interface or the Avigilon Control Center software, adjust the camera's Image and Display settings. You can set the zoom position, focus, and change the image rotation.

## (Optional) Configuring SD Card Storage

To use the camera's SD card storage feature, you must insert an SD card into the card slot.

It is recommended that the SD card have a capacity of 8 GB or more and a write speed of class 6 or better. If the SD card does not meet the recommended capacity or write speed, the recording performance may suffer and result in the loss of frames or footage.

1. Insert an SD card into the camera.



**CAUTION** — Do not force the SD card into the camera or you may damage the card and the camera. The SD card can only be inserted in one direction.

2. Access the camera's web interface to enable the onboard storage feature. For more information, see the *Avigilon High Definition H4 and H5 IP Camera Web Interface User Guide*.

## Setting the Time

If you are installing an H4 ES camera, you must set the time on the camera. The ES camera model includes a built-in server component that runs the ACC Server software directly on the camera. Since the camera is accessed as its own network video recording server, you must set the time so that events and recorded video occur at the correct time.

Follow the below procedure to manually configure the time settings:

1. Log in to the camera web interface.
2. Display the **Setup > General** page.
3. In the Time Settings area, select the camera time zone.
4. Click **Apply**.
5. At the bottom of the Time Settings area, click the **Configure NTP Server** link.

If you cannot see the link, select **Network** from the left menu pane.

6. In the NTP Server area, make sure the check box is selected then choose one of the following options:
  - **DHCP** select this option to automatically use an NTP server on the network.
  - **Manual** select this option to manually enter a specific NTP server address in the **NTP Server** field.
7. Click **Apply**.

## Installing the Dome Cover

Be careful not to touch or scratch the dome bubble. Any marks or fingerprints on the dome bubble will cause unwanted reflections in the -IR model.

1. Attach the lanyard to the dome cover.

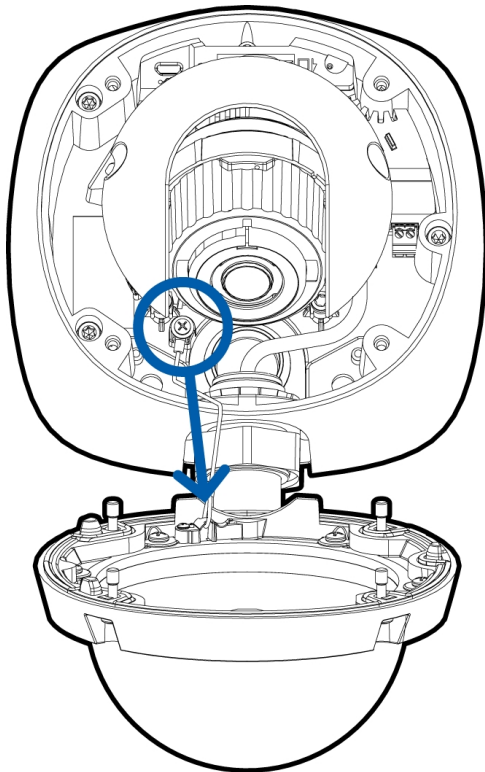

2. Remove the plastic cover on the inside of the dome bubble.
3. Attach the dome cover to the base by tightening the screws with the star-shaped key.
4. Remove the plastic cover on the dome bubble.

## Zooming and Focusing the Dome Camera

Ensure this procedure is performed after the dome cover is installed, so you can accommodate for the focus shift caused by the dome bubble.

- In the camera web browser interface or the Avigilon Control Center software, use the camera's Image and Display settings to zoom and focus the camera.
  - a. Use the zoom buttons to zoom the camera in or out.
  - b. Click **Auto Focus** to focus the lens.
  - c. Use the focus near and far buttons to manually adjust the focus.

## Configuring the Camera

Once installed, use one of the following methods to configure the camera:

- If you have the USB Wifi Adapter, you can access the mobile web interface to configure the camera. For more information, see *Avigilon USB Wi-Fi Adapter System User Guide*.
- If you have installed multiple cameras, you can use the Avigilon Camera Configuration Tool to configure common settings. For more information, see the *Avigilon Camera Configuration Tool User Guide*.
- If the camera is connected to the Avigilon Control Center system, you can use the client software to configure the camera. For more information, see the *Avigilon Control Center Client User Guide*.
- If the camera is connected to a third-party network management system, you can configure the camera's specialty features in the camera's web browser interface. For more information, see the *Avigilon High Definition H4 and H5 IP Camera Web Interface User Guide*.
- If you installed an H4 ES camera, you can use the Avigilon Control Center Client software to configure the camera and the embedded software.

## For More Information

Additional information about setting up and using the device is available in the following guides:

- *Avigilon Control Center Client User Guide*
- *Web Interface User Guide — Avigilon High Definition H4 and H5 IP Cameras*
- *Avigilon USB Wi-Fi Adapter System User Guide*
- *Avigilon Camera Configuration Tool User Guide*
- *Designing a Site with Avigilon Video Analytics*

These guides are available on [help.avigilon.com](https://help.avigilon.com) and on the Avigilon website: [avigilon.com/support-and-downloads](https://avigilon.com/support-and-downloads).



# Cable Connections

## Connecting External Power

If PoE is not available, the camera needs to be powered through the removable power connector block. Refer to the diagrams in this guide for the location of the power connector block.

The power consumption information is listed in the product specifications.

To connect power to the power connector block, complete the following steps:

1. Remove the power connector block from the camera.
2. Remove the insulation from ¼" (6 mm) of the power wires. Do not nick or damage the wires.
3. Insert the two power wires into the two terminals on the power connector block. The connection can be made with either polarity.

Use a small slotted (5/64" or 2 mm blade width) screwdriver to loosen and tighten the terminals.

4. Attach the power connector block back into the camera.



**WARNING** — This product is intended to be supplied by a UL Listed Power Unit marked “Class 2” or “LPS” or “Limited Power Source” with output rated 12 VDC or 24 VAC, 7 W min. (9 W min. with -IR model) or PoE rated 48 VDC, 7 W min. (9 W min. with -IR model).

## Connecting to External Devices

External devices are connected to the camera through the I/O terminal block. The pinout for the I/O terminal block is shown in the following diagram:

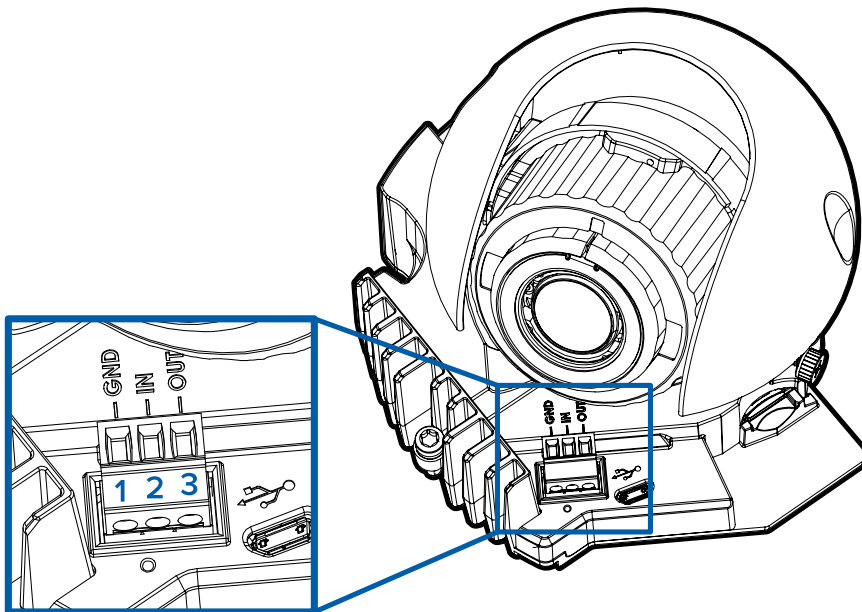

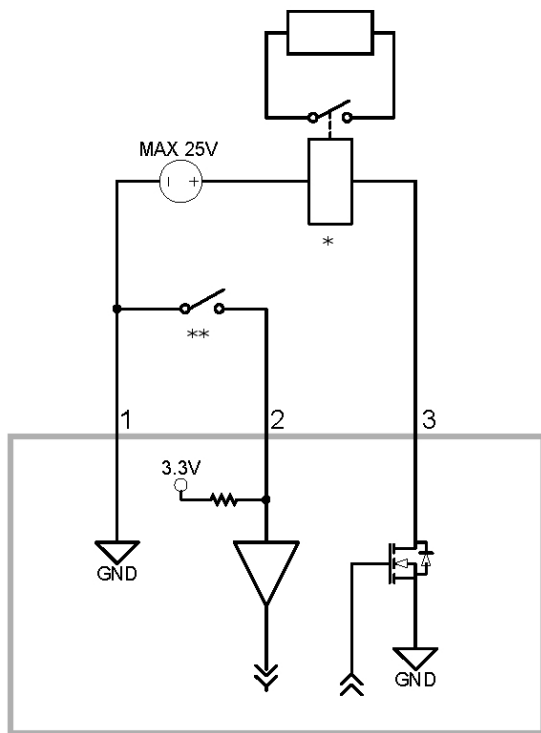

**Figure 1:** Example application.

1. Ground
  2. Input — To activate, connect the Input to the Ground pin. To deactivate, leave disconnected or apply between 3-15 V.
  3. Output — When active, Output is internally connected with the Ground pin. Circuit is open when inactive. Maximum load is 25 VDC, 120 mA.
- \* — Relay
  - \*\* — Switch

## Connecting to Microphones, Speakers, and Video Monitors

The camera can be connected to an external microphone, speaker and video monitor through the mini-jack (3.5 mm) audio/video connector (Avigilon part number CM-AC-AVIO1).

Only the 2.0 megapixel models can be connected to an external video monitor through the A/V connector.

**Note:** The camera only supports line level mono audio input and an NTSC or PAL video output.

The video output signal is determined by the camera flicker control setting. When the camera flicker control is set to 60 Hz, the video output signal is NTSC. When the flicker control is set to 50 Hz, the video output signal is PAL. Use the Camera Installation Tool to configure the camera's flicker control in the Image and Display setup.

The pinout for the connector is shown in the following diagram:

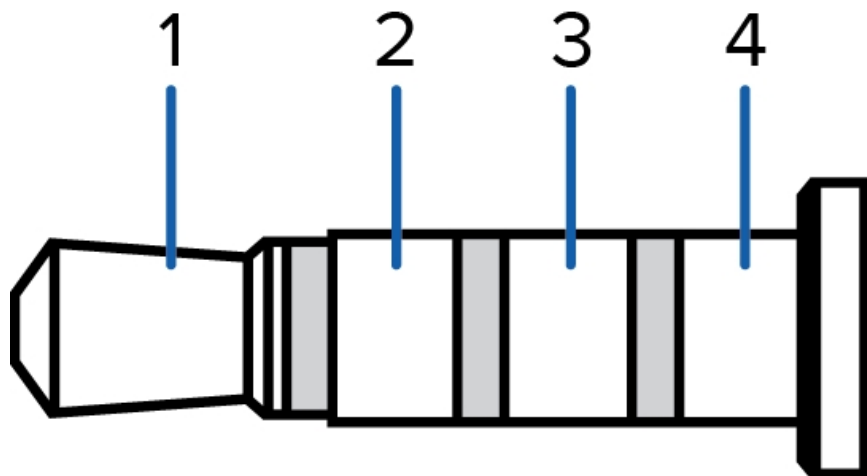

The wiring for the connector pinout is shown in the following table:

Pin	Purpose	Wire
1	Audio IN	Red
2	Composite Video OUT	Black
3	GND	Yellow
4	Audio OUT	Green

# Connection Status LED Indicator

Once connected to the network, the Connection Status LED indicator will display the progress in connecting to the Network Video Management software.

The following table describes what the LED indicator shows:

<b>Connection State</b>	<b>Connection Status LED Indicator</b>	<b>Description</b>
Obtaining IP Address	One short flash every second	Attempting to obtain an IP address.
Discoverable	Two short flashes every second	Obtained an IP address but not connected to the Network Video Management software.
Upgrading Firmware	Two short flashes and one long flash every second	Updating the firmware.
Connected	On	Connected to the Network Video Management software or an ACC™ Server. The default connected setting can be changed to Off using the camera's web user interface. For more information see the <i>Avigilon High Definition H4 and H5 IP Camera Web Interface User Guide</i> .

# Resetting to Factory Default Settings

If the device no longer functions as expected, you can choose to reset the device to its factory default settings.

Use the firmware revert button to reset the device. The firmware revert button is shown in the following diagram:

**Note:** For the ES camera models, resetting the camera will erase all recorded video from the camera.

For models that feature an SD card slot, resetting the camera will not affect video that has been recorded to the SD card.

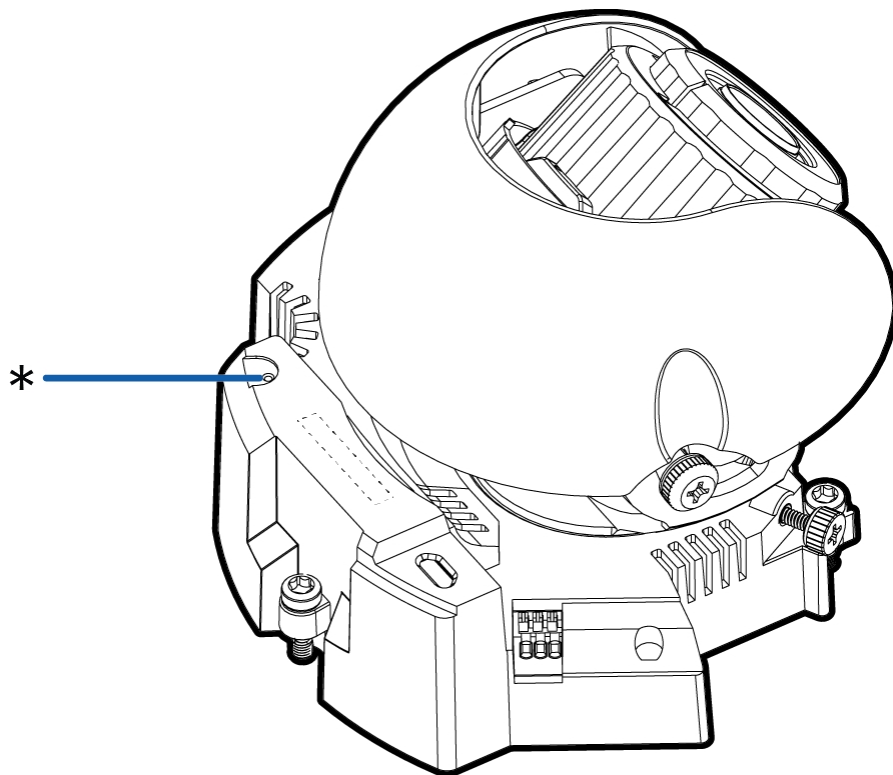

**Figure 2:** The firmware revert button on the dome camera.

1. Ensure the device is powered on.
2. Using a straightened paperclip or similar tool, gently press and hold the firmware revert button.
3. Release the button after three seconds.



**CAUTION** — Do not apply excessive force. Inserting the tool too far may damage the camera.

# Setting the IP Address Using the ARP/Ping Method

Complete the following steps to configure the camera to use a specific IP address:

**Note:** The ARP/Ping Method will not work if the **Disable setting static IP address through ARP/Ping method** check box is selected in the camera's web browser interface. For more information, see the *Avigilon High Definition H4 and H5 IP Camera Web Interface User Guide*.

1. Locate and make note of the MAC Address (MAC) listed on the Serial Number Tag for reference.
2. Open a Command Prompt window and enter the following commands:

- a. `arp -s <New Camera IP Address> <Camera MAC Address>`

For example: `arp -s 192.168.1.10 00-18-85-12-45-78`

- b. `ping -l 123 -t <New Camera IP Address>`

For example: `ping -l 123 -t 192.168.1.10`

3. Reboot the camera.
4. Close the Command Prompt window when you see the following message:

Reply from <New Camera IP Address>: ...

# Cleaning

## Dome Bubble

If the video image becomes blurry or smudged in areas, it may be because the dome bubble requires cleaning.

To clean the dome bubble:

- Use hand soap or a non-abrasive detergent to wash off dirt or fingerprints.
- Use a microfiber cloth or non-abrasive fabric to dry the dome bubble.

**Important:** Failure to use the recommended cleaning materials may result in a damaged or scratched dome bubble. A damaged dome bubble may negatively impact image quality and cause unwanted IR light reflecting into the lens.

## Body

- Use a dry or lightly dampened cloth to clean the camera body.
- Do not use strong or abrasive detergents.

# Limited Warranty and Technical Support

Avigilon warranty terms for this product are provided at [avigilon.com/warranty](https://www.avigilon.com/warranty).

Warranty service and technical support can be obtained by contacting Avigilon Technical Support: [avigilon.com/contact-us/](https://www.avigilon.com/contact-us/).