

# User Guide

Avigilon H4 Thermal Elevated Temperature Detection  
Camera

H4A-ETD-KIT

# Legal Notices

© 2020, Avigilon Corporation. All rights reserved. AVIGILON, the AVIGILON logo, AVIGILON CONTROL CENTER, and ACC are trademarks of Avigilon Corporation. ONVIF is a trademark of Onvif, Inc. Other names or logos mentioned herein may be the trademarks of their respective owners. The absence of the symbols ™ and ® in proximity to each trademark in this document or at all is not a disclaimer of ownership of the related trademark. Avigilon Corporation protects its innovations with patents issued in the United States of America and other jurisdictions worldwide (see [avigilon.com/patents](https://www.avigilon.com/patents)). Unless stated explicitly and in writing, no license is granted with respect to any copyright, industrial design, trademark, patent or other intellectual property rights of Avigilon Corporation or its licensors.

## Disclaimer

This document has been compiled and published using product descriptions and specifications available at the time of publication. The contents of this document and the specifications of the products discussed herein are subject to change without notice. Avigilon Corporation reserves the right to make any such changes without notice. Neither Avigilon Corporation nor any of its affiliated companies: (1) guarantees the completeness or accuracy of the information contained in this document; or (2) is responsible for your use of, or reliance on, the information. Avigilon Corporation shall not be responsible for any losses or damages (including consequential damages) caused by reliance on the information presented herein.

Avigilon Corporation  
avigilon.com

PDF-H4-ETD-A

Revision: 5 - EN

20201223

# Important Safety Information

This manual provides installation and operation information and precautions for the use of this device. Incorrect installation could cause an unexpected fault. Before installing this equipment read this manual carefully. Please provide this manual to the owner of the equipment for future reference.



This Warning symbol indicates the presence of dangerous voltage within and outside the product enclosure that may result in a risk of electric shock, serious injury or death to persons if proper precautions are not followed.



This Caution symbol alerts the user to the presence of hazards that may cause minor or moderate injury to persons, damage to property or damage to the product itself if proper precautions are not followed.



**WARNING** — Failure to observe the following instructions may result in severe injury or death.

- Installation must be performed by qualified personnel only, and must conform to all local codes.
- This product is intended to be supplied by a UL Listed Power Unit marked “Class 2” or “LPS” or “Limited Power Source” with output rated 12 VDC or 24 VAC, 9 W min. or Power over Ethernet (PoE), rated 48 VDC, 9 W min.
- Do not connect directly to mains power for any reason.



**CAUTION** — Failure to observe the following instructions may result in injury to persons or damage to the device.

- Do not expose the camera directly to high levels of x-ray, laser, or UV radiation. Direct exposure may cause permanent damage to the image sensor.
- Do not install near any heat sources such as radiators, heat registers, stoves, or other sources of heat.
- Do not subject the device cables to excessive stress, heavy loads or pinching.
- Do not open or disassemble the device. There are no user serviceable parts.
- Refer all device servicing to qualified personnel. Servicing may be required when the device has been damaged (such as from a liquid spill or fallen objects), has been exposed to rain or moisture, does not operate normally, or has been dropped.
- Do not use strong or abrasive detergents when cleaning the device body.
- Use only accessories recommended by Avigilon.

## Regulatory Notices

This device complies with part 15 of the FCC Rules. Operation is subject to the following two conditions: (1) this device may not cause harmful interference, and (2) this device must accept any interference received, including interference that may cause undesired operation.

This Class B digital apparatus complies with Canadian ICES-003.

This equipment has been tested and found to comply with the limits for a Class B digital device, pursuant to Part 15 of the FCC rules. These limits are designed to provide reasonable protection against harmful interference in a residential installation. This equipment generates, uses and can radiate radio frequency energy and, if not installed and used in accordance with the instructions, may cause harmful interference to radio communications. However, there is no guarantee that interference will not occur in a particular installation. If this equipment does cause harmful interference to radio or television reception, which can be determined by turning the equipment off and on, the user is encouraged to try to correct the interference by one or more of the following measures:

- Reorient or relocate the receiving antenna.
- Increase the separation between the equipment and the receiver.
- Connect the equipment into an outlet on a circuit different from that to which the receiver is connected.
- Consult the dealer or an experienced radio/TV technician for help.

Changes or modifications made to this equipment not expressly approved by Avigilon Corporation or parties authorized by Avigilon Corporation could void the user's authority to operate this equipment.

## Elevated Temperature Detection

**Important:** Temperature measurements obtained by the H4 Thermal Elevated Temperature Detection camera should not be solely relied upon to diagnose or exclude a diagnosis of COVID-19 or any other disease. Elevated skin temperatures should be confirmed with a secondary method such as an FDA-approved thermometer.

Use the following guidelines when using the H4 Thermal Elevated Temperature Detection camera:

- Public health officials should determine the significance of any fever or elevated temperature based on the skin telethermographic temperature measurement.
- The camera should be used to measure only one subject's temperature at a time.
- Visible thermal patterns are only intended for locating the points from which to extract the thermal measurement.
- The blackbody is used as a thermal drift compensation reference source and is an important part in obtaining an accurate temperature assessment.

- The system should only be used in indoor environments with a stable ambient temperature between 18 °C and 24 °C (65 °F to 75 °F), and located in an area that is not subject to air drafts from radiator or HVAC systems.
- Install the solution with a neutral backdrop behind the target subject. The camera's field of view should not be directed towards outdoor entrance or exit points, and should not include thermally reflective surfaces or strong lighting. The relative humidity in the screening area should be maintained at below 50%. Elevated humidity and/or ambient temperature can affect the temperature readings and may cause the subject to sweat.
- This device is not FDA-cleared at this time.



**WARNING** — Do not modify this equipment without the authorization of the manufacturer.

## Disposal and Recycling Information

When this product has reached the end of its useful life, please dispose of it according to your local environmental laws and guidelines.

Risk of fire, explosion, and burns. Do not disassemble, crush, heat above 100 °C (212 °F), or incinerate.

### European Union:



This symbol means that according to local laws and regulations your product should be disposed of separately from household waste. When this product reaches its end of life, take it to a collection point designated by local authorities. Some collection points accept products for free. The separate collection and recycling of your product at the time of disposal will help conserve natural resources and ensure that it is recycled in a manner that protects human health and the environment.

# Table of Contents

Overview .....	1
Camera View .....	1
Mounting Bracket View .....	2
Tripod View .....	3
Blackbody View .....	4
Tilt Adjuster View .....	5
Front View .....	6
Configuration Panel View .....	7
Side View .....	8
Kit Package Contents .....	8
Setting Up an Elevated Temperature Detection Station .....	9
Installation Guidelines .....	9
Preparing Individuals for Screening .....	10
Installation .....	11
Tripod Mount Installation Option .....	11
Installing the Camera on the Tripod .....	11
Connecting Cables .....	12
Wall Mount Installation Option .....	13
Installing the Mounting Bracket .....	13
(Optional) Removing the Shroud .....	14
Reinstalling the Shroud .....	15
Connecting Cables .....	15
Mounting the Camera .....	16
Replacing the Configuration Panel Cover .....	17
Aiming the Camera .....	17
Blackbody Installation .....	18
Connecting to the Camera .....	20
Initializing a Camera Username and Password .....	20
(Optional) Using the USB Wi-Fi Adapter .....	20
Assigning an IP Address .....	21
(Optional) Configuring SD Card Storage .....	21
Initial Camera Setup and Configuration .....	23
Setting the Blackbody Region of Interest .....	23
Verifying the Temperature Accuracy and Adjusting the Offset .....	23

Configuring ACC for Elevated Temperature Detection .....	25
Configuring Skin Temperature Thresholds .....	25
Adding a Temperature Analytic Event .....	26
Toggling Degrees Celsius and Fahrenheit .....	26
Connecting to Power and External Devices .....	27
Connection Status LED Indicator .....	29
Troubleshooting Network Connections and LED Behavior .....	29
Maintaining the System .....	31
Blackbody Maintenance .....	31
Resetting to Factory Default Settings .....	32
Setting the IP Address Using the ARP/Ping Method .....	33
For More Information .....	34
Limited Warranty and Technical Support .....	35

# Overview

## Camera View

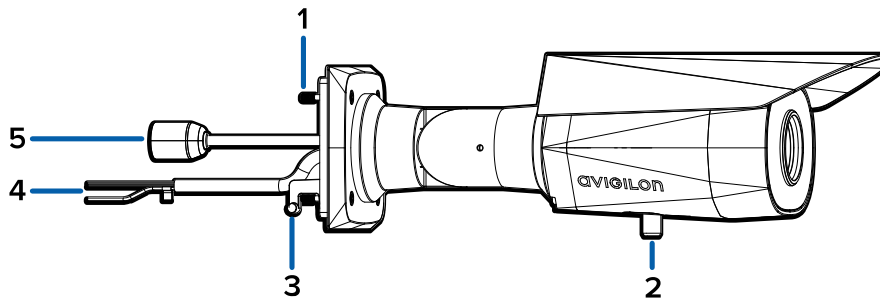

1. **Camera mounting screws**

Screws for mounting the camera to the mounting bracket.

2. **Tripod mount**

Screw for mounting the camera to the tripod or tilt adjuster.

3. **Mounting hooks**

Hooks to attach the camera to the mounting bracket while connecting the required cables.

4. **Power and I/O cables**

Cables for connecting the camera to auxiliary power and I/O devices. For more information, see *Connecting to Power and External Devices* on page 27.

5. **Ethernet port**

Accepts an Ethernet connection to a network. Server communication and image data transmission occurs over this connection. Also receives power when it is connected to a network that provides Power over Ethernet.



## Mounting Bracket View

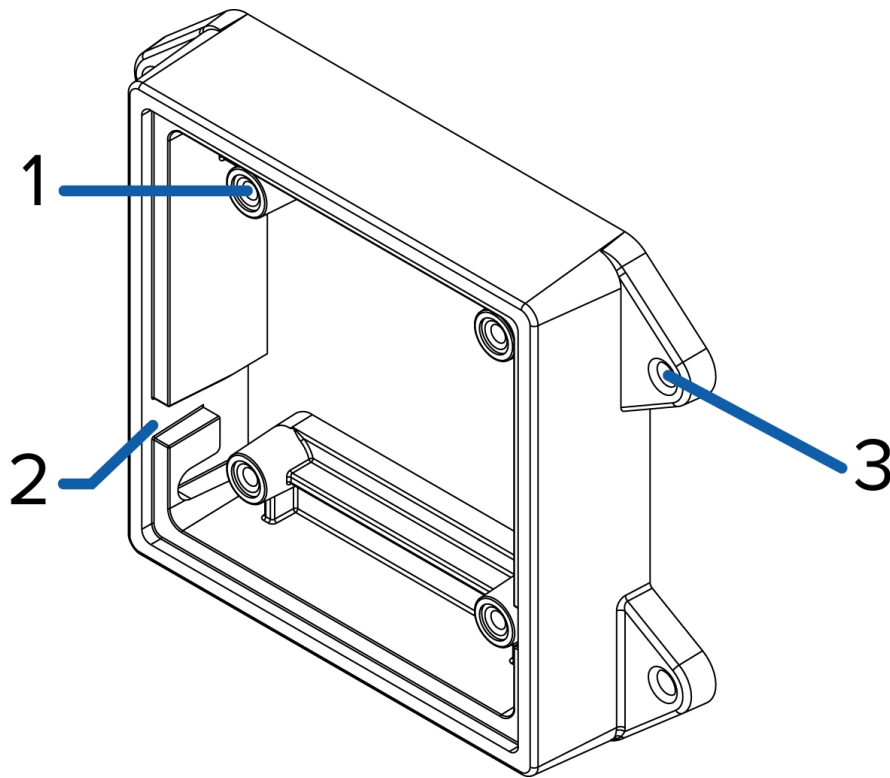

**Note:** Mounting bracket is not used when the camera is mounted on a tripod.

1. **Camera mounts**

Points for installing the camera to the mounting bracket.

2. **Mounting hook slots**

Points to hold the camera to the mounting bracket while connecting the required cables.

3. **Mounting holes**

Holes for securing the mounting bracket to the mounting surface.

# Tripod View

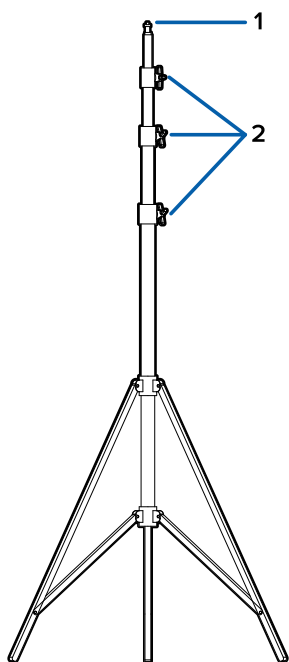

1. **Mount**

Mounting point for attaching to the camera or blackbody.

2. **Height adjustment knobs (x3)**

Knobs for adjusting and locking the height of the tripod. Loosen a knob and slide the tripod to the desired height. Tighten the knobs to lock the tripod to the desired height.

# Blackbody View

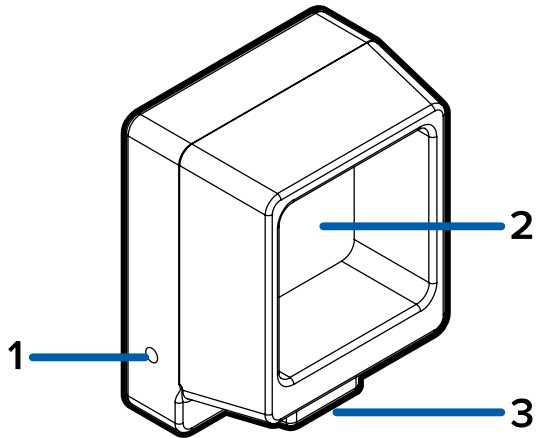

1. **Power connector**

Port for connecting to the included power supply.

2. **Blackbody front**

The part of the blackbody that must be directly facing the camera.

3. **Tripod mount**

Screw for mounting the camera to the tripod or tilt adjuster.

## Tilt Adjuster View

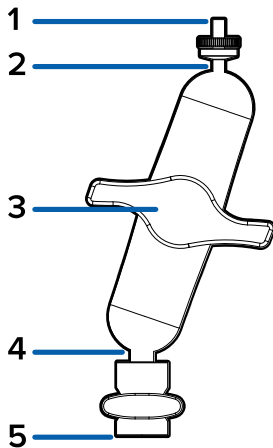

1. **Camera/Blackbody mount**

Mounting point for connecting to the camera or the blackbody.

2. **Top tilt adjustment**

Move to adjust the angle of the mounted camera or blackbody.

3. **Tilt lock**

Loosen to adjust the tilt angle. Tighten to lock to the desired angle.

4. **Bottom tilt adjustment**

Move to adjust the angle of the mounted camera or blackbody.

5. **Tripod mount**

Mounting point for connecting to the tripod.

## Front View

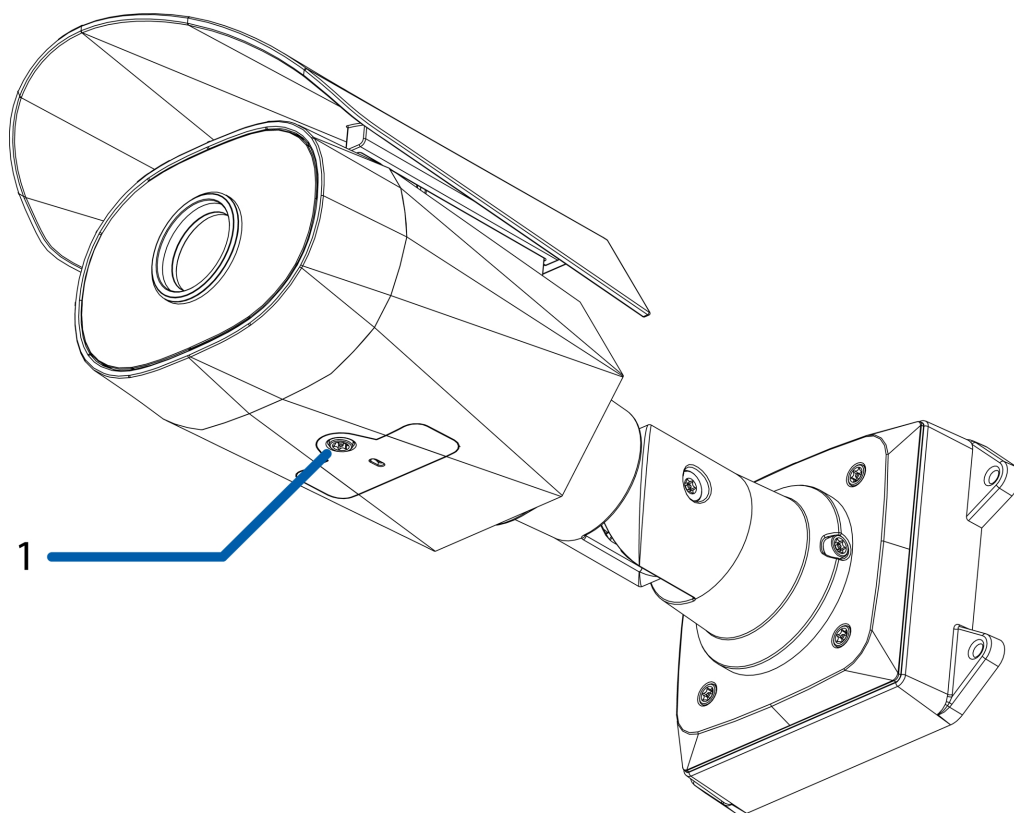

### 1. Configuration panel cover

Covers the configuration panel. Showing the configuration panel without the tripod mount. For more information on the configuration panel, see the *Configuration Panel View* on the next page.

# Configuration Panel View

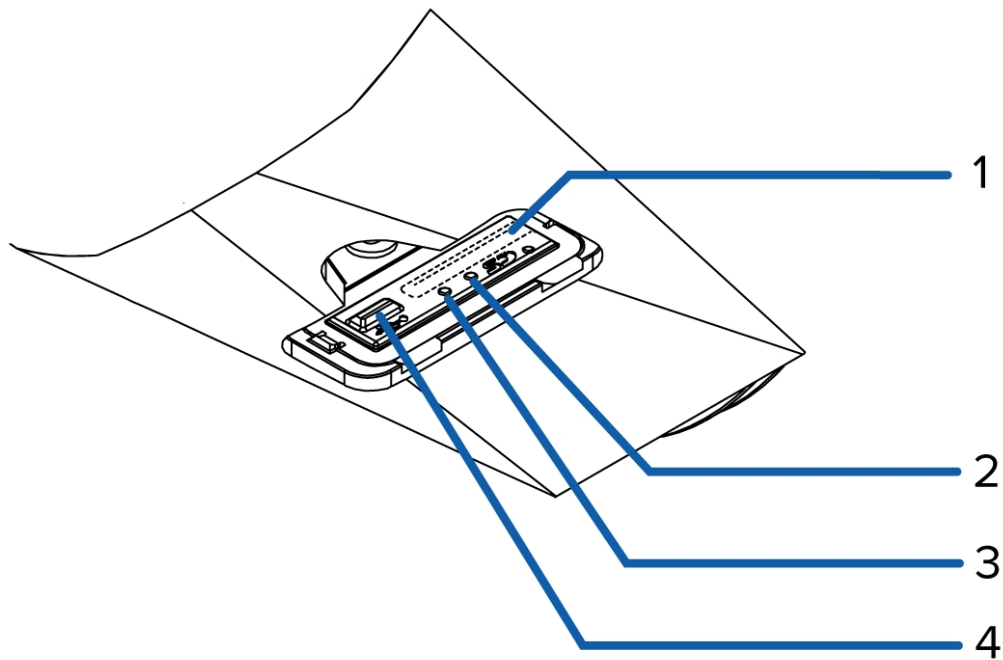

1. **SD card slot**

Accepts an SD card for onboard storage.

2. **Link LED indicator**

Amber LED indicates if there is an active connection in the Ethernet port.

3. **Connection status LED indicator**

Green LED provides information about device operation. For more information, see *Connection Status LED Indicator* on page 29.

4. **Micro USB port**

Accepts a micro USB to USB adapter. Only required when using the Avigilon USB Wi-Fi Adapter.

## Side View

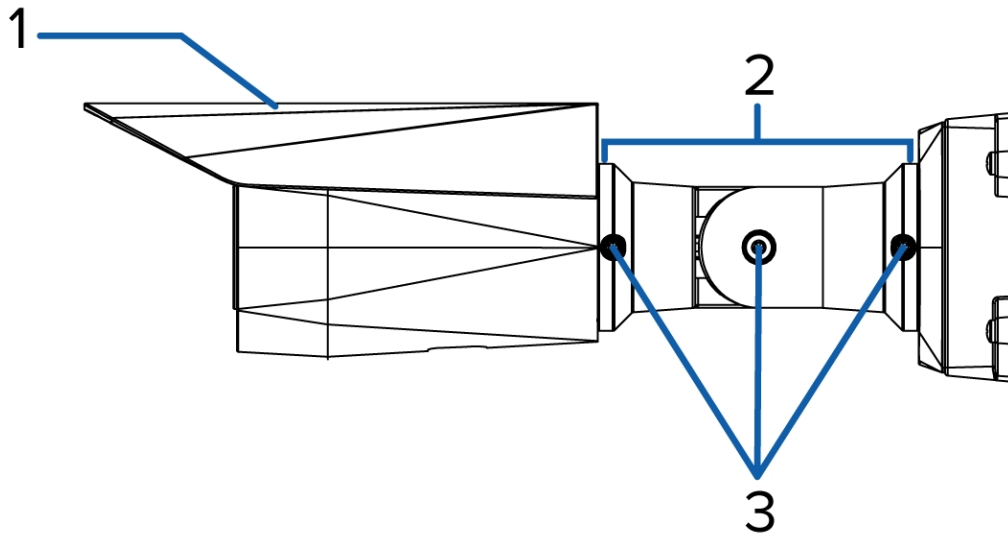

1. **Shroud**  
An adjustable cover to help protect the lens against glare.
2. **Mount arm**  
Adjustable mount arm for positioning the camera.
3. **Adjustment screws**  
Provides a locking mechanism for the mount arm.

## Kit Package Contents

- Avigilon H4A Thermal Camera
  - Spacer for tripod mounting
  - Panel cover without tripod mount connector
  - Mounting template sticker
  - 4 screws and anchors for solid walls
  - Protective cable boot
  - T20 Pin-In star-shaped driver
- Blackbody and power supply
- Tripod (x2)
- Tilt adapter for tripod mounts (x2)

# Setting Up an Elevated Temperature Detection Station

To properly setup an Elevated Temperature Detection station, many factors will need to be assessed and taken into account to obtain optimal and accurate results for the temperature detection.

Review the installation guidelines and recommendations for preparing subjects for screening before installing the camera and other components.

## Installation Guidelines

**Note:** ACC software version 7.10 or later is required to use the elevated temperature features.

Pay particular attention to the following guidelines when setting up your elevated temperature detection station:

- The H4 Thermal Elevated Temperature Detection solution is designed as an initial screening system of individuals for elevated skin temperature.
- The system should only be used in indoor environments with a stable ambient temperature between 18 °C and 24 °C (65 °F to 75 °F), and located in an area that is not subject to air drafts from radiator or HVAC systems.
- Install the solution with a neutral backdrop behind the target subject. The camera's field of view should not be directed towards outdoor entrance or exit points, and should not include thermally reflective surfaces or strong lighting.
- Refer to the diagram below for an example of an ideal camera and blackbody setup.
  - Height of camera: 1.5m - 2m (5 ft - 6.5 ft)
  - Height of blackbody: 1.5m - 2m (5 ft - 6.5 ft)

**Note:** The height guidelines for the camera and blackbody are designed for the average height of an adult subject. If this system will be used to screen children, the heights of the camera and blackbody may need to be adjusted to account for the lower height of the subjects.

- Distance between blackbody and camera: 1.5m (5 ft)
- Distance between person and camera: 1.5m (5 ft)



- The blackbody should be positioned such that it does not get occluded when a person steps in front of the camera for screening. A recommended option is to have the blackbody positioned slightly higher than the typical individual's head and around 0.3m (1 ft) to the side of where the individuals will stand. Be mindful of the tripod placement to ensure that people will not trip over the legs of the stand.
- Make sure the front of the blackbody is perpendicular to the camera. An angled blackbody setup may reduce the accuracy of the temperature measurement.
- Mark the place for a person to stand for screening with tape or other clear marking.
- Ensure the camera position and placement of the individual is such that it is easy for the person to look directly into the camera.

**Note:** Make sure that the blackbody and face of the person are clearly visible within the inner 80% of the camera's field of view and not at the edge of the frame.

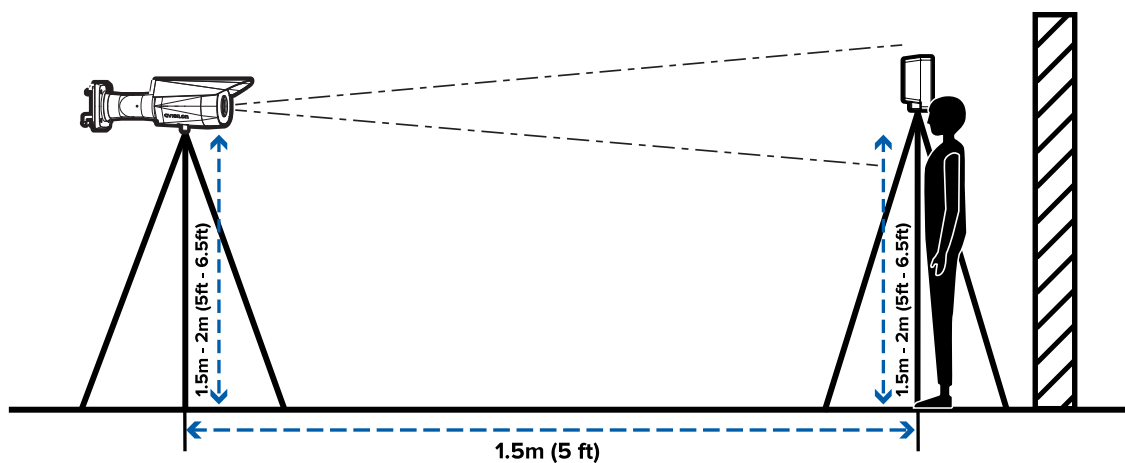

## Preparing Individuals for Screening

The elevated temperature detection solution can only be used for screening one person at a time for elevated skin temperature.

- Ensure the person is acclimated to the indoor environment before stepping in front of the camera.
- To screen for elevated skin temperature, the thermal camera must get a clear view of the inner canthus (tear duct) region. The person must not have any occlusion around the eye area: glasses should be removed and any hat or headband should be clear of the eye area.
- Once in front of the camera, the person must look straight at the camera for 2-3 seconds.
- The throughput for screening can be as high as 10 people per minute, but may be lower depending on your layout and process.
- Ensure that the blackbody is not obstructed when the subject is screened.

# Installation

## Tripod Mount Installation Option

For typical elevated temperature detection stations, the thermal camera will be installed on a tripod and positioned in front of the individual and the blackbody. For more information, see *Installation Guidelines* on page 9.

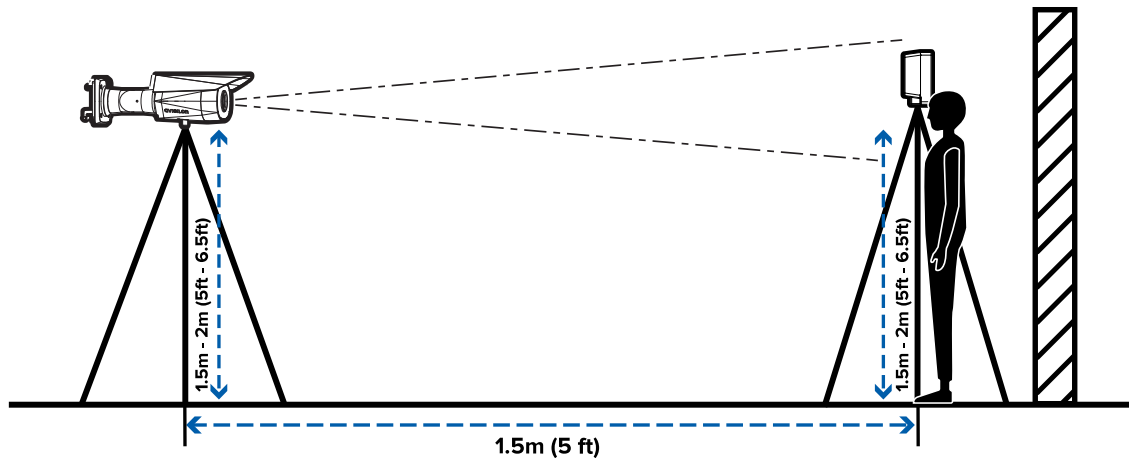

## Installing the Camera on the Tripod

Follow the *Installation Guidelines* on page 9 for the recommended position and height of the camera.

1. Open the tripod legs and use the height adjustment knobs to set the to 1.5m to 2m (5 ft - 6.5 ft).
2. Remove the taped spacer from the underside of the camera.
3. Screw the camera onto the tripod mount with the spacer positioned in between (B).

Optionally, you can screw the tilt adjuster onto the tripod and then screw the camera onto the tilt adjuster with the spacer positioned in between (A). Adjust the tilt to ensure the camera is positioned at a proper viewing angle.

Aim the camera at the blackbody and screened individual. The camera should be positioned close to horizontal and should avoid steep angles.

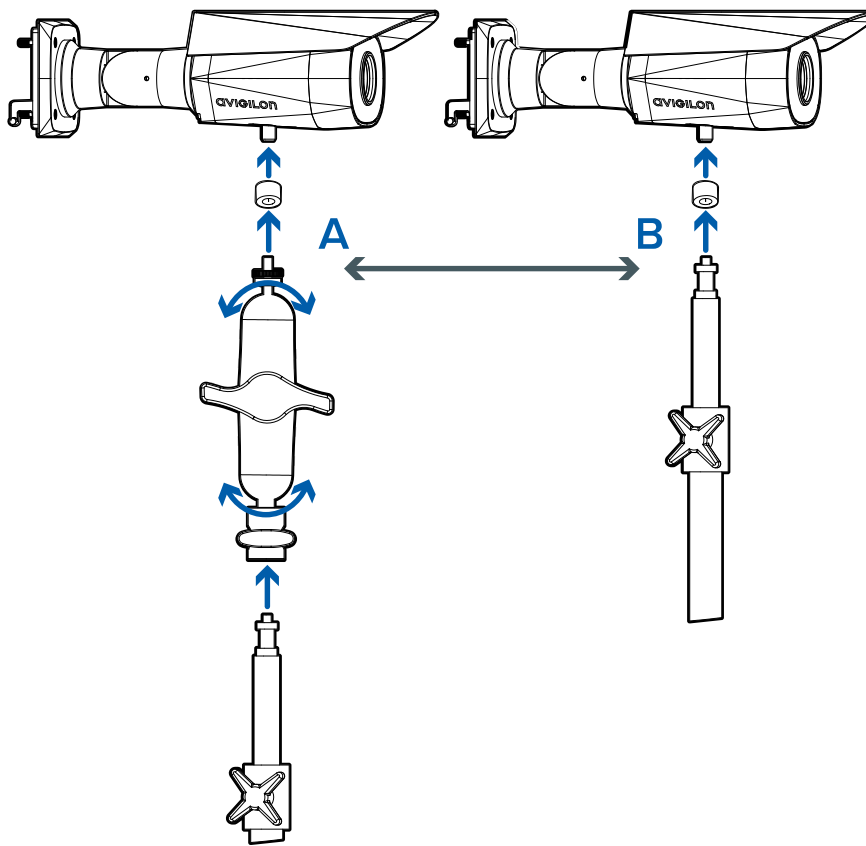

4. Lock the tilt adjustment knob, if used, and the tripod height adjustment knobs.
5. Position tripod so the camera is directly facing the blackbody and subject.

## Connecting Cables

1. If there are external input or output devices that need to be connected to the camera (for example: light, LED, door contacts, relays, etc.), connect the devices to the camera's digital I/O connector cables. For more information see *Connecting to Power and External Devices* on page 27.
2. If an external microphone and/or speakers need to be connected to the camera, connect the devices to the camera's audio I/O cables. For more information, see *Connecting to Power and External Devices* on page 27.
3. Connect a network cable to the Ethernet port (RJ-45 connector).  
The Link LED indicator will turn on once a network link has been established.
4. Connect power using one of the following methods:

- Power over Ethernet (PoE) Class 3 — If PoE is available, the camera LEDs will turn on.
- External Power — Connect an external 12 V DC or 24 V AC power source through the brown and blue auxiliary power cables.

**Important:** Be careful not to connect power to the audio input cable, doing so will permanently damage the camera. Both the audio input cable and auxiliary power cable are brown. To distinguish the auxiliary power cable, it is labeled *AUX PWR* and has a thicker gauge.

5. Check that the Connection Status LED indicator indicates the correct state. For more information, see *Connection Status LED Indicator* on page 29.

## Wall Mount Installation Option

For a more permanent and less obtrusive thermal camera installation, you can mount the camera to a wall so that it is positioned in front of the elevated temperature detection subject and the blackbody. For more information, see *Installation Guidelines* on page 9.

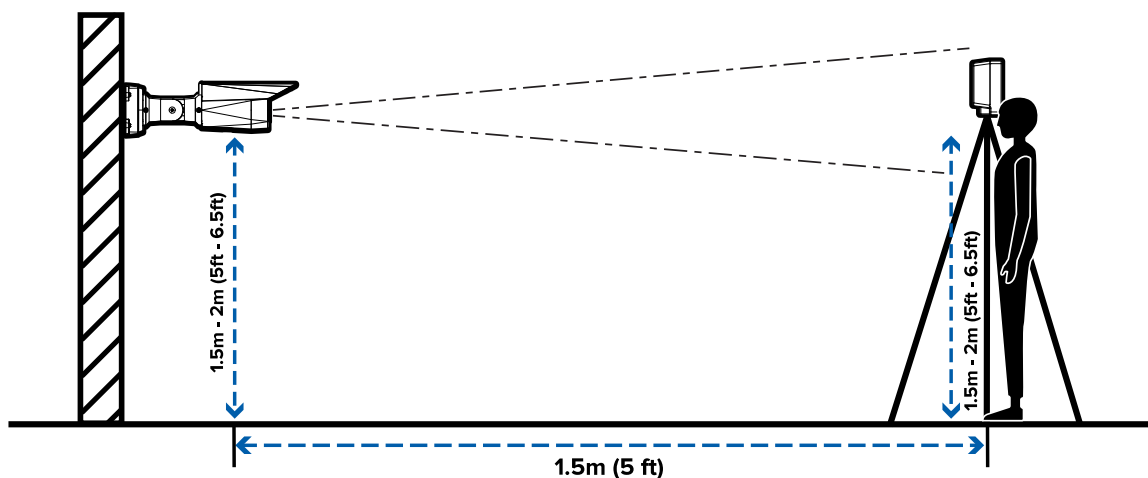

### Installing the Mounting Bracket

If the cables for the camera will not be provided from inside the mounting surface, install the junction box first (H4-BO-JBOX). It is highly recommended that the junction box be used if you will be installing the camera with auxiliary power or external digital inputs and outputs.

After you install the junction box, you can skip directly to step 3 of this procedure.

1. Use the mounting template to drill four mounting holes into the mounting surface.
2. Drill the cable entry hole into the mounting surface then pull the required cables through the cable entry hole.
3. Fasten the mounting bracket or the junction box to the mounting surface.

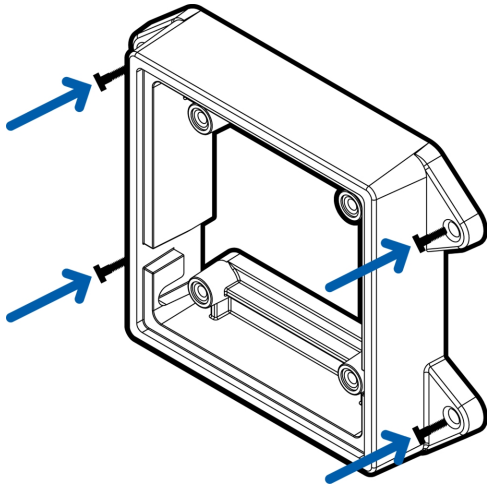

**Note:** It is recommended that silicone sealant be applied around the edge of the mounting bracket or junction box to prevent moisture from entering the mounting surface.

4. Insert the mounting hooks on the rear of the camera into the mounting hook slots on the mounting bracket, then let the camera hang.

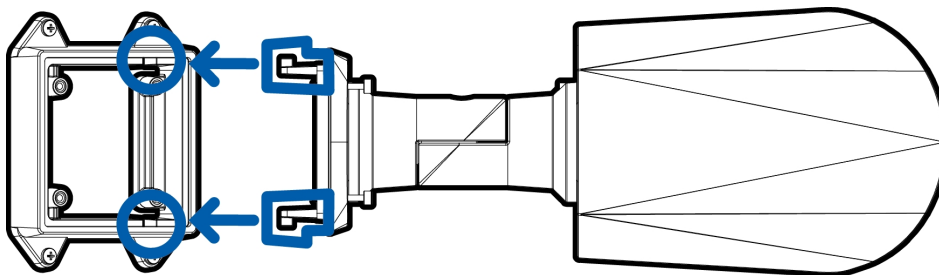

## (Optional) Removing the Shroud

The shroud should only be removed when the camera is installed indoors and space is limited.

1. As you press down on the center of the shroud, pull up the corners of the shroud from one side of the camera.
2. Use a T20 Pin-In star-shaped driver to unscrew and remove the shroud mount from the camera.

## Reinstalling the Shroud

1. Use a T20 Pin-In star-shaped driver to screw on the shroud mount.
2. Align one side of the shroud to the mount.
3. Press down on the center of the shroud and flex the edges up, then lower it into place.

## Connecting Cables

1. If there are external input or output devices that need to be connected to the camera (for example: door contacts, relays, etc.), connect the devices to the camera's digital I/O connector cables. For more information see *Connecting to Power and External Devices* on page 27.
2. If an external microphone and/or speakers need to be connected to the camera, connect the devices to the camera's audio I/O cables. For more information, see *Connecting to Power and External Devices* on page 27.
3. Install the protective cable boot. You may choose to skip this step if you are using the optional junction box.

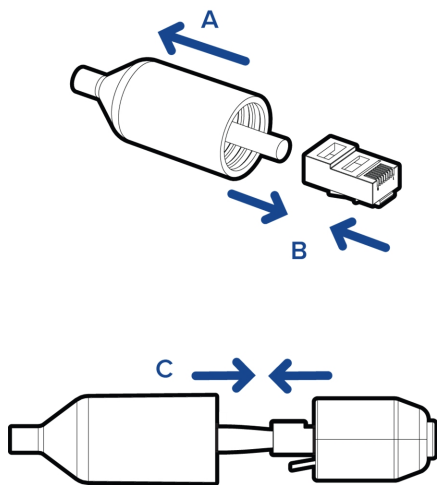

- a. Remove the protective cable boot that is preinstalled over the Ethernet port, then thread one end of the Ethernet cable through it.  
Ensure the orientation of the cable and boot matches the one shown in the image.
  - b. Crimp the Ethernet cable.
  - c. After you connect the cable to the camera, slide the boot over the Ethernet port.
4. Connect a network cable to the Ethernet port (RJ-45 connector).  
The Link LED indicator will turn on once a network link has been established.
  5. Connect power using one of the following methods:

- Power over Ethernet (PoE) Class 3 — If PoE is available, the camera LEDs will turn on.
- External Power — Connect an external 12 V DC or 24 V AC power source through the brown and blue auxiliary power cables.

**Important:** Be careful not to connect power to the audio input cable, doing so will permanently damage the camera. Both the audio input cable and auxiliary power cable are brown. To distinguish the auxiliary power cable, it is labeled *AUX PWR* and has a thicker gauge.

6. Check that the Connection Status LED indicator indicates the correct state. For more information, see *Connection Status LED Indicator* on page 29.

## Mounting the Camera

Once all the cable connections have been made, secure the camera to the mounting bracket.

1. Tuck the extra lengths of cables into the cable entry hole.
2. Secure the camera to the mounting bracket:
  - a. Raise the camera until it covers the mounting bracket.

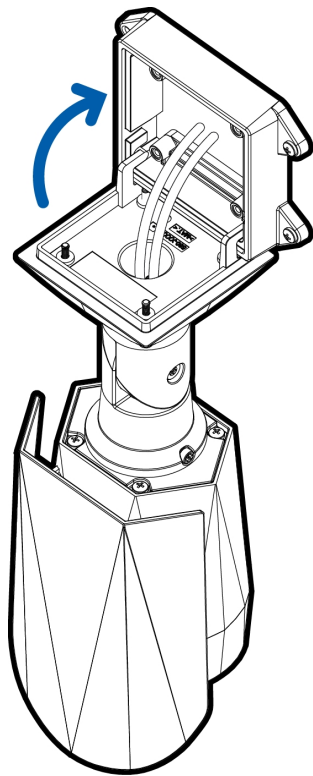

- b. Use the camera mounting screws to fasten the camera to the bracket.

## Replacing the Configuration Panel Cover

If you are mounting to a wall and do not require the tripod mount, you can replace the configuration panel with one that does not include the tripod mount.

**Note:** This step is required for wall mounting the camera.

1. Use a T20 Pin-In star-shaped driver to unscrew the configuration panel cover (A). Remove the cover.

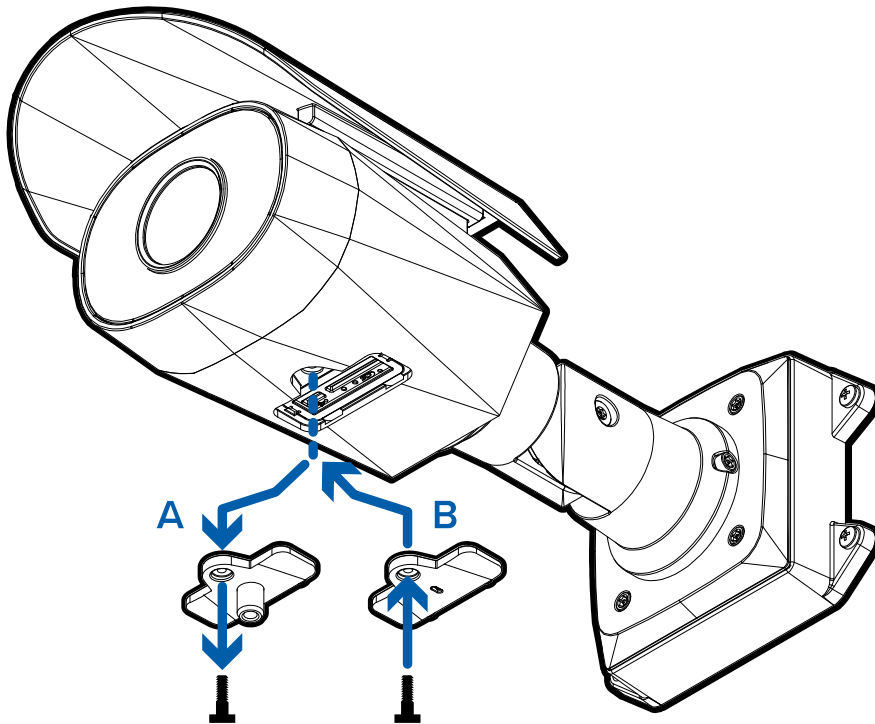

2. Use the T20 Pin-In star-shaped driver to screw in the supplied extra configuration panel cover (B).

## Aiming the Camera

Reference the camera's live stream as you aim the camera.

1. To aim the camera, loosen the adjustment screws on the camera mount arm.
2. Rotate and move the camera and mount arm as required. Review the camera's live video stream to help aim the camera correctly.

Aim the camera at the blackbody and screened individual. The camera should be positioned close to horizontal and should avoid steep angles.



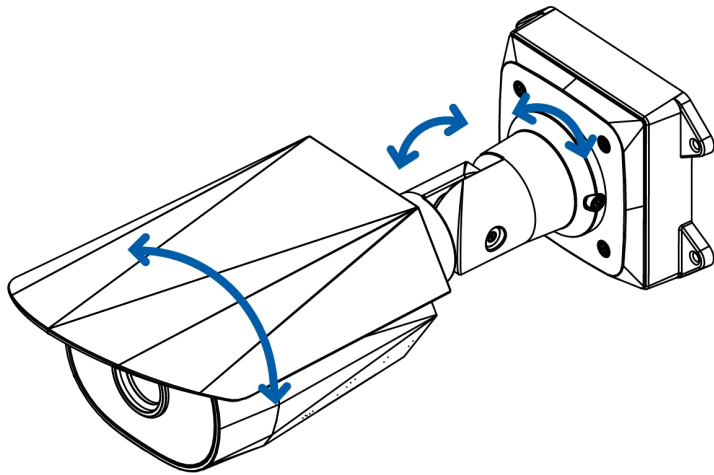

3. Tighten the adjustment screws on the mount arm to secure the camera's position.
4. In the camera web browser interface or the Avigilon Control Center software adjust the camera's Image and Display settings. You can change the image rotation.

## Blackbody Installation

Follow the *Installation Guidelines* on page 9 for the recommended position and height of the blackbody.

Blackbody devices are shipped to be calibrated for 35 °C (95 °F) and ready to be used with the camera. No further calibration is required.

1. Open the tripod legs and use the height adjustment knobs to set the to 1.5m to 2m (5 ft - 6.5 ft).
2. Screw the blackbody onto the tripod mount (B).

Optionally, you can screw the tilt adjuster onto the tripod and then screw the blackbody onto the tilt adjuster (A). Adjust the tilt to ensure the blackbody is positioned at the correct angle.

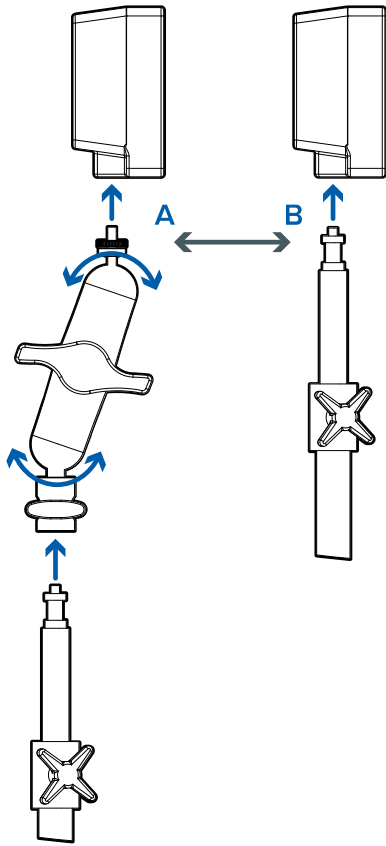

3. Lock the tilt adjustment knob, if used, and the tripod height adjustment knobs.
4. Remove the protective cover from the blackbody device.
5. Connect the power supply to the blackbody. Wait 5 minutes for the blackbody to power up. Verify the LED on the blackbody is on and not blinking.

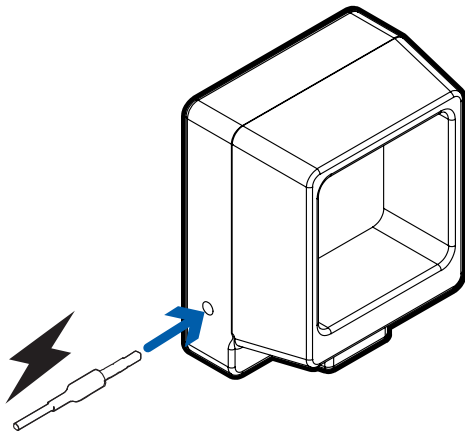

6. Position tripod and blackbody so the front of the blackbody is directly facing the thermal camera. For

more information, see *Blackbody View* on page 4.

**Note:** Make sure that the blackbody and face of the person are clearly visible within the inner 80% of the camera's field of view and not at the edge of the frame.

## Connecting to the Camera

### Initializing a Camera Username and Password

Cameras manufactured after January 1, 2020, do not have a default username or password and will be in a factory default state.

**Important:** You must create a user with *administrator* privileges before the camera is operational.

The first user can be created using any of the following methods:

- Camera's Web Interface: enter the camera's IP address in a web browser to access the web interface. If the camera is in the factory default state you will be redirected to the Add a new user page to create the first user. For more information, see the *Avigilon High Definition H4 and H5 IP Camera Web Interface User Guide*.
- Camera Configuration Tool version 1.4.4 or later: cameras discovered in the factory default state will be identified by . Select the **Admin Users** tab to create the first user. For more information, see the *Avigilon Camera Configuration Tool User Guide*.
- USB Wi-Fi Adapter: when connecting a camera in the factory default state, you will be redirected to the Create Administrator User page to create the first user. For more information, see *Avigilon USB Wi-Fi Adapter System User Guide*.
- Avigilon Control Center software: when connecting a camera in the factory default state, the client software will ask you to create a new user. For more information, see the *Avigilon Control Center Client User Guide*.

### (Optional) Using the USB Wi-Fi Adapter

If you have a USB Wi-Fi Adapter (H4-AC-WIFI), attach it to the camera's micro USB port to access the camera's mobile web interface.

After you connect to the Wi-Fi signal broadcast by the adapter, you can access the mobile web interface from any mobile device using the following address:

http://camera.lan

For more information about configuring the camera from the mobile web interface see *Avigilon USB Wi-Fi Adapter System User Guide*.

**Note:** The camera will reserve the 10.11.22.32/28 subnet for internal use while the USB Wi-Fi Adapter is plugged in.

## Assigning an IP Address

The device automatically obtains an IP address when it is connected to a network.

**Note:** If the device cannot obtain an IP address from a DHCP server, it will use Zero Configuration Networking (Zeroconf) to choose an IP address. When set using Zeroconf, the IP address is in the 169.254.0.0/16 subnet.

The IP address settings can be changed using one of the following methods:

- The mobile web interface using the USB Wifi Adapter. For more information, see *(Optional) Using the USB Wi-Fi Adapter* on the previous page.
- Device's web browser interface: `http://<camera IP address>/`.
- Network Video Management software application (for example, the Avigilon Control Center™ software).
- ARP/Ping method. For more information, see *Setting the IP Address Using the ARP/Ping Method* on page 33.

**Note:**

Depending on the manufacture date of your camera, you will have one of the two options below to log in for the first time:

- Cameras manufactured after January 1, 2020: these cameras do not have a default username or password and will be in a factory default state. **You must create a user with administrator privileges before the camera is operational.** For more information, see *Initializing a Camera Username and Password* on the previous page.
- Cameras manufactured before January 1, 2020: login to the camera using the default username of `administrator` with no password. It is recommended that you change the password after your first login.

## (Optional) Configuring SD Card Storage

To use the camera's SD card storage feature, you must insert an SD card into the card slot.

It is recommended that the SD card have a capacity of 8 GB or more and a write speed of class 6 or better. If the SD card does not meet the recommended capacity or write speed, the recording performance may suffer and result in the loss of frames or footage.

1. Insert an SD card into the camera.



**CAUTION** — Do not force the SD card into the camera or you may damage the card and the camera. The SD card can only be inserted in one direction.

2. Access the camera's web interface to enable the onboard storage feature. For more information, see the *Avigilon High Definition H4 and H5 IP Camera Web Interface User Guide*.

# Initial Camera Setup and Configuration

## Setting the Blackbody Region of Interest

Before setting the blackbody region of interest, make sure that the camera and blackbody are installed and positioned correctly to detect temperatures. For more information, see *Installation Guidelines* on page 9.

1. Access the camera's web browser interface at `http://< camera IP address >/`.
2. Open the **Elevated Temperature** page.
3. On the camera's video image, move and resize the blackbody ROI so that it covers the blackbody temperature area in the image. The blackbody ROI must be placed completely within the gray area of the blackbody and should not have any portion outside of that area.

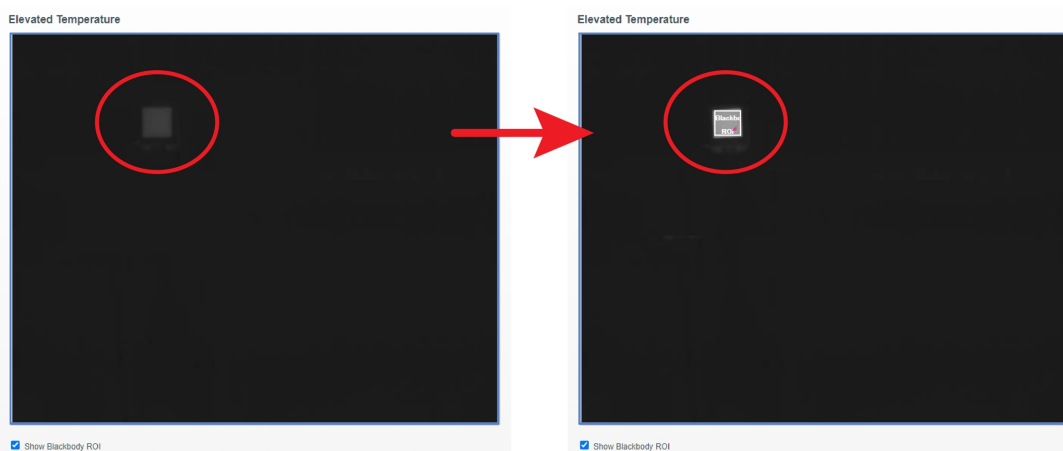

**Note:** If the blackbody position or camera angle is changed at all after setting the blackbody ROI, the placement of the blackbody ROI will have to be updated for that change.

4. Click **Apply** to save your settings.

## Verifying the Temperature Accuracy and Adjusting the Offset

Before verifying the camera's temperature accuracy, you must discover and connect your elevated temperature detection camera in your ACC system. For more information, see the *Avigilon Control Center Client User Guide*.

1. Launch and login to your ACC Client. Open a live view for the elevated temperature detection camera.
2. Manually take the body temperature of a test subject using a clinical thermometer or other trusted and accurate temperature device. Make a note of this temperature. It is recommended that you take more than one measurement to ensure a proper reading. If using an infrared forehead thermometer, set it to body temperature mode.
3. Send the test subject to the testing area 1.5m (5 ft) in front of the camera. Make sure to follow the guidelines as outlined in *Preparing Individuals for Screening* on page 10.
4. Note the temperature reading for the test subject in the ACC Client. Compare this temperature reading with the temperature reading obtained of the subject in *step 2*. If these two temperatures match, no further actions are required.
5. If the two temperatures readings are different, calculate the difference. This number will be your temperature offset.

For example, if the manually obtained temperature reading is 98.6 °F, and the ACC Client temperature reading is 98.2 °F, the offset is 0.4 °F.

6. Access the camera's web browser interface at `http://< camera IP address >/` and open the **Elevated Temperature** page.
7. Enter your calculated **Temperature Offset** in the provided field. Ensure that the unit of measurement you used in your calculation, °C or °F, is selected.
8. Click **Apply** to save your settings.

# Configuring ACC for Elevated Temperature Detection

ACC software version 7.10 or later is required for use with the H4 Thermal Elevated Temperature Detection camera.





In an ACC Client, you can configure the skin temperature threshold for subjects with elevated and low temperatures. Subjects that fall in between the elevated and low temperature thresholds will be considered as being within the acceptable range.

You can also set up analytic temperature events to record events for a specified temperature threshold.

## Configuring Skin Temperature Thresholds

Configure the thresholds for detecting skin temperatures on faces in live video.

**Note:** The following button is supported only for the Avigilon H4 Thermal Elevated Temperature Detection camera.

1. In the New Task menu , click **Site Setup**.
2. Select a thermal camera and click **Temperature Settings** .
3. In the **Temperature Settings** dialog box, edit as needed:
  - **Elevated Temperature Threshold (°C) or (°F):** The threshold above which a person may need further screening. Default is the calibrated value from the thermal camera.  
  
If an elevated temperature at or above the threshold is detected,  and a red bounding box are displayed over the face in the live video.
  - **Lower Temperature Threshold (°C) or (°F):** The threshold below which a person may need further screening. Default is the calibrated value from the thermal camera.  
  
If a lower temperature at or below the threshold is detected,  and a white bounding box are displayed over the face in the live video.



Any temperature detection that falls between the specified thresholds is considered within the acceptable range. If a temperature is detected,  and a green bounding box are displayed over the face in the live video.
4. Click **Restore Defaults** to restore the calibrated value from the camera, if needed.
5. Click **OK** to apply the settings and exit, or click **Apply** to apply the settings without exiting.

Next, you can configure analytics events. For more information, see *Adding a Temperature Analytic Event* on the next page.



# Adding a Temperature Analytic Event

The temperature events can be used to set up notifications or rules.

1. In the New Task menu , click **Site Setup**.
2. Select a camera, then click **Analytic Events**  .
3. Click **Add**.
4. Enter a name. This should be unique throughout the ACC site.
5. Select the **Enabled** checkbox. If the checkbox is clear, the video analytics event will not detect or trigger any events.
6. Select the type of temperature event you want to add in **Activity:** and configure the event settings:
  - If **Object with elevated temperature** is selected, configure the **Elevated Temperature Threshold (°C)** or **(°F)**: The threshold above which a person may need further screening. Default is the calibrated value from the thermal camera. Any temperature detection above this threshold will trigger the event.
  - If **Object with lower temperature** is selected, configure the **Lower Temperature Threshold (°C)** or **(°F)**: The threshold below which a person may need further screening. Default is the calibrated value from the thermal camera. Any temperature detection below this threshold will trigger the event.
  - If **Object with expected temperature** is selected, configure both the lower and elevated temperature thresholds. Any temperature detection that falls between the specified thresholds is considered within the acceptable range and will trigger the event.

When a detected temperature matches the threshold defined, the event triggers the camera to record for the specified duration.

7. People is automatically selected as the **Object Types:** and cannot be changed.  
Ignore the Sensitivity:, Number of Objects:, and Threshold Time: settings.
8. In Timeout:, select the recording duration for the event from 2 to 15 seconds. The default setting is 8 seconds.
9. Click **OK** to save your settings.

## Toggling Degrees Celsius and Fahrenheit

Toggle the temperature unit that displays next to the bounding box on faces in live video and in related temperature detection activity events.

1. In the Windows Control Panel, select **Region** and **Additional settings**.
2. Select the unit in **Measurement system**.
3. Click **OK**. The temperature unit takes effect immediately.

# Connecting to Power and External Devices

**Important:** Be careful not to connect auxiliary power to the audio input wire or the camera will be damaged. Although both the audio input wire and auxiliary power wire are brown, the auxiliary power wire is distinguished by its thicker wire gauge and *AUX PWR* label.

If PoE is not available, the camera may be powered through the auxiliary power cable using either 12 V DC or 24 V AC. The power consumption information is listed in the product specifications.

To power the camera, connect the two power wires to the brown and blue auxiliary power wires. The connection can be made with either polarity.

**WARNING** — This product is intended to be supplied by a UL Listed Power Unit marked “Class 2” or “LPS” or “Limited Power Source” with output rated 12 VDC or 24 VAC, 9 W min. or Power over Ethernet (PoE), rated 48 VDC, 9 W min.

Power supplies and external devices are connected to the camera through the power and I/O wires. The pinout for the I/O and power wires is shown in the following diagram:

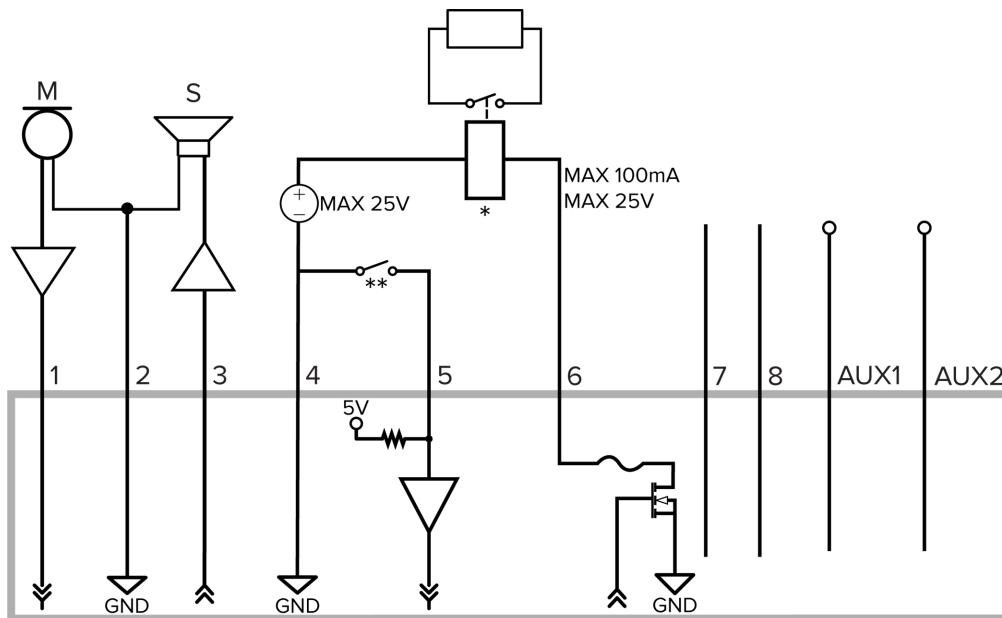

Figure 1: Example application.

1. Brown — Audio Input (line level)

An external power amplifier should be used when connecting speakers and microphones, as shown in the diagram.

2. Yellow — Audio Ground

3. Green — Audio Output (line level)
  4. Grey — Ground
  5. Red — Digital Input
  6. Pink — Digital Output
  7. Purple — Reserved Wire, do not connect.
  8. White — Reserved Wire, do not connect.
- \* — Relay
  - \*\* — Switch
  - M — Microphone
  - S — Speaker
  - AUX1 — Brown Auxiliary Power Wire, labeled *AUX PWR*
  - AUX2 — Blue Auxiliary Power Wire

# Connection Status LED Indicator

Once connected to the network, the green Connection Status LED indicator will display the progress in connecting to the Network Video Management software.

The following table describes what the LED indicator shows:

Connection State	Connection Status LED Indicator	Description
Obtaining IP Address	One short flash every second	Attempting to obtain an IP address.
Discoverable	Two short flashes every second	Obtained an IP address but not connected to the Network Video Management software.
Upgrading Firmware	Two short flashes and one long flash every second	Updating the firmware.
Connected	On	Connected to the Network Video Management software or an ACC™ Server. The default connected setting can be changed to Off using the camera's web user interface. For more information see the <i>Avigilon High Definition H4 and H5 IP Camera Web Interface User Guide</i> .

## Troubleshooting Network Connections and LED Behavior

**Note:** For any of the below LED behaviors, ensure that the camera is getting power and is using a good network cable before trying another solution.

LED Behavior	Suggested Solution
<ul style="list-style-type: none"><li>Green LED is off and amber is on</li></ul>	Perform a factory reset of the camera using the physical firmware revert button. Resetting through the camera's web interface will not produce the desired result.
<ul style="list-style-type: none"><li>Both LEDs are off and the camera is not connected or streaming video</li></ul>	Check the <b>General</b> setup page in the camera's web interface to ensure the LEDs are not disabled.  If the LEDs are not disabled, perform a factory reset of the camera using the physical firmware revert button. Resetting through the camera's web interface will not produce the desired result.

**LED Behavior****Suggested Solution**

- 
- Both LEDs are blinking several times at the same time, then pause and repeat the blinking

Perform a factory reset of the camera using the physical firmware revert button. Resetting through the camera's web interface will not produce the desired result.

- 
- A different LED blinking pattern than those described above

Perform a factory reset of the camera using the physical firmware revert button. Resetting through the camera's web interface will not produce the desired result.

# Maintaining the System

## Blackbody Maintenance

The blackbody device requires manufacturer calibration and testing every 2 years to have the device's certification maintained. Please contact Avigilon to arrange sending your device for calibration after 2 years. Warranty service and technical support can be obtained by contacting Avigilon Technical Support: [avigilon.com/contact](https://www.avigilon.com/contact).

# Resetting to Factory Default Settings

If the device no longer functions as expected, you can choose to reset the device to its factory default settings.

Use the firmware revert button to reset the device. The firmware revert button is shown in the following diagram:

For models that feature an SD card slot, resetting the camera will not affect video that has been recorded to the SD card.

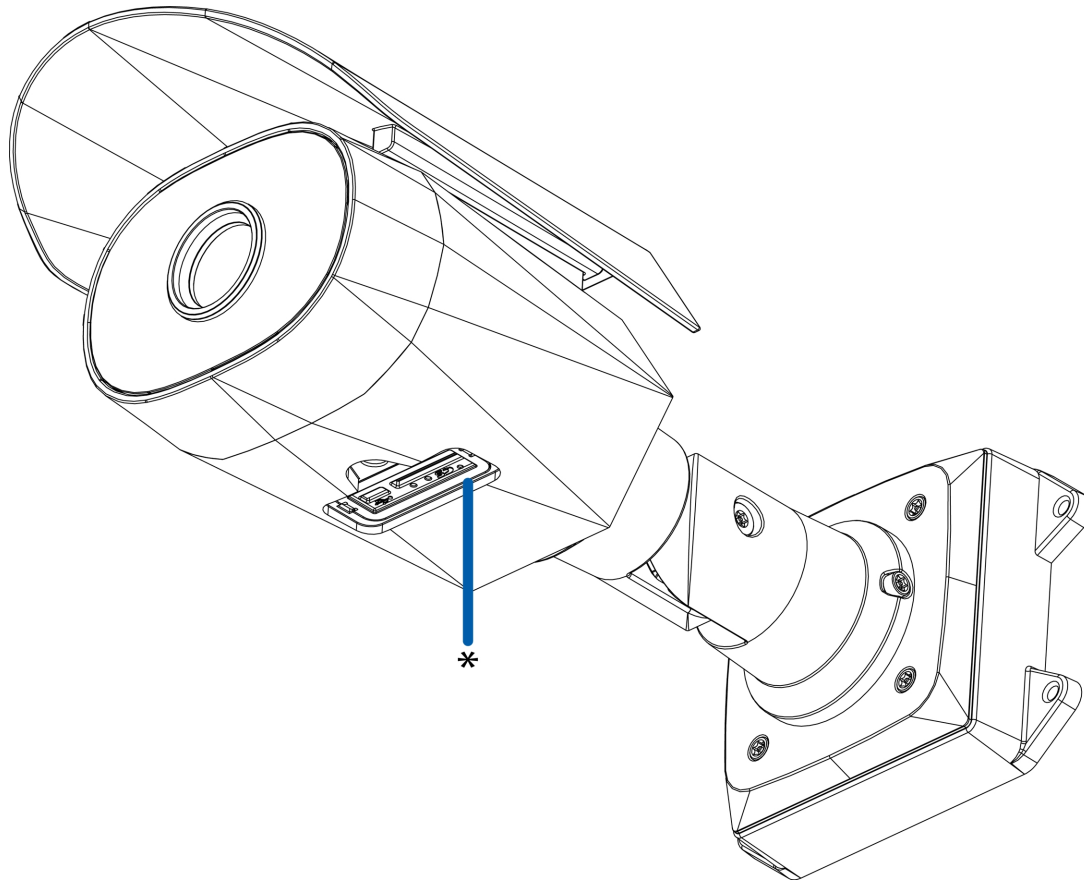

**Figure 2:** The firmware revert button in the Configuration Panel.

1. Ensure the camera is powered on.
2. Unscrew the configuration panel cover on the bottom of the camera.
3. Using a straightened paperclip or similar tool, gently press and hold the firmware revert button for 3 seconds.
4. Screw the configuration panel cover back into place.



**CAUTION** — Do not apply excessive force. Inserting the tool too far may damage the camera.

# Setting the IP Address Using the ARP/Ping Method

Complete the following steps to configure the camera to use a specific IP address:

**Note:** The ARP/Ping Method will not work if the **Disable setting static IP address through ARP/Ping method** checkbox is selected in the camera's web browser interface. For more information, see the *Avigilon High Definition H4 and H5 IP Camera Web Interface User Guide*.

1. Locate and make note of the MAC Address (MAC) listed on the Serial Number Tag for reference.
2. Open a Command Prompt window and enter the following commands:
  - a. `arp -s <New Camera IP Address> <Camera MAC Address>`  
For example: `arp -s 192.168.1.10 00-18-85-12-45-78`
  - b. `ping -l 123 -t <New Camera IP Address>`  
For example: `ping -l 123 -t 192.168.1.10`
3. Reboot the camera.
4. Close the Command Prompt window when you see the following message:

Reply from <New Camera IP Address>: ...



# For More Information

Additional information about setting up and using the device is available in the following guides:

- *Avigilon Control Center Client User Guide*
- *Web Interface User Guide — Avigilon High Definition H4 and H5 IP Cameras*
- *Avigilon USB Wi-Fi Adapter System User Guide*
- *Avigilon Camera Configuration Tool User Guide*

These guides are available on [help.avigilon.com](http://help.avigilon.com) and on the Avigilon website: [avigilon.com/support](http://avigilon.com/support).

# Limited Warranty and Technical Support

Avigilon warranty terms for this product are provided at [avigilon.com/warranty](https://www.avigilon.com/warranty).

Warranty service and technical support can be obtained by contacting Avigilon Technical Support: [avigilon.com/contact](https://www.avigilon.com/contact).