

Analytics Kit

HD-NVR-ANK2-1

For:

NVR Value Series 4 (HD-NVR4-VAL)

HD NVR Series 3 (HD-NVR3-VAL, HD-NVR3-STD, HD-NVR3-PRM)

HD NVR Series 2

VMA-AS3-ANK

For:

16- and 24-Port Video Appliance (VMA-AS3-16P, VMA-AS3-24P)

© 2020, Avigilon Corporation. All rights reserved. AVIGILON, the AVIGILON logo, AVIGILON CONTROL CENTER, ACC, and AVIGILON APPEARANCE SEARCH are trademarks of Avigilon Corporation. Other names or logos mentioned herein may be the trademarks of their respective owners. The absence of the symbols ™ and ® in proximity to each trademark in this document or at all is not a disclaimer of ownership of the related trademark. Avigilon Corporation protects its innovations with patents issued in the United States of America and other jurisdictions worldwide (see avigilon.com/patents). Unless stated explicitly and in writing, no license is granted with respect to any copyright, industrial design, trademark, patent or other intellectual property rights of Avigilon Corporation or its licensors.

This document has been compiled and published using product descriptions and specifications available at the time of publication. The contents of this document and the specifications of the products discussed herein are subject to change without notice. Avigilon Corporation reserves the right to make any such changes without notice. Neither Avigilon Corporation nor any of its affiliated companies: (1) guarantees the completeness or accuracy of the information contained in this document; or (2) is responsible for your use of, or reliance on, the information. Avigilon Corporation shall not be responsible for any losses or damages (including consequential damages) caused by reliance on the information presented herein.

Avigilon Corporation
avigilon.com

PDF-QSG-GPU-C

Revision: 1 - EN

20200409

This device is provided with a battery powered real-time clock (RTC) circuit. There is a danger of explosion if the RTC battery is incorrectly replaced. Replace only with same or equivalent type recommended by the manufacturer. Discard used batteries according to the manufacturer's instructions.

This equipment is to be connected only to PoE networks without routing to the outside plant.

Table of Contents

Analytics Kit for NVRs and Video Appliances	4
Installing the Analytics Kit into the NVR4-VAL or HD-NVR3-VAL	6
Installing NVR Analytics Kit into the HD-NVR3-PRM or HD-NVR3-STD	9
Installing the Analytics Kit into the HD-NVR2	12
Updating and Configuring the NVR for Analytics	15
Updating Windows PowerShell (Windows Server 2012 only)	15
Updating the Windows OS Driver and Configuring the NVR	16
Troubleshooting the NVR Appliance Fans	18
Installing the Analytics Kit into the 16 Port or 24 Port Video Appliance	19
Updating and Configuring the 16 Port or 24 Port Video Appliance for Analytics	21

Analytics Kit for NVRs and Video Appliances

Two versions of the Analytics Kit are available:

- Analytics Kit for NVRs (HD-NVR-ANK2-1)
- Analytics Kit for Video Appliances (VMA-AS3-ANK)

Install the Analytics Kit for NVRs (HD-NVR-ANK2-1) to use the Avigilon Control Center (ACC™) video analytics features on the following Avigilon recorders:

- Any NVR Value (Series 4) model
- Any NVR (Series 3) models
- The NVR (Series 2)

Important: The Windows operating system on some NVR3 Standard (NVR3-STD) and NVR3 Value (NVR3-VAL) models and all NVR2 models must be upgraded to Windows 10 before installing the Analytics Kit. Earlier versions of Windows do not support the kit.

If your NVR3 Standard or Value model has not been upgraded to Windows 10, refer to the online [Avigilon Windows 10 Field Upgrade Guide](https://www.avigilon.com/support/technical/os-field-upgrade) (<https://www.avigilon.com/support/technical/os-field-upgrade>).

If your NVR2 model has not been upgraded to Windows 10, download *Windows 10 Operating System Upgrade for Avigilon NVR2 and AS1 Recorders* from the [Avigilon Technical Support website](https://www.avigilon.com/support/technical/os-upgrade) (<https://www.avigilon.com/support/technical/os-upgrade>).

Install the Analytics Kit for Video Appliances (VMA-AS3-ANK) to use the Avigilon Control Center (ACC™) video analytics features on the following Avigilon appliances:

- Any HD Video Appliance Pro 16 Port model
- Any HD Video Appliance Pro 24 Port model

Installation of the Analytics Kit for NVRs (HD-NVR-ANK2-1) or Video Appliances (VMA-AS3-ANK) is a four-step procedure:

1. Install the physical kit into the device.
2. Update the Windows OS software of the device.

Note: The OS updates required for the NVRs depend on the series of the NVR (Series 2, 3, or 4) and the version of the Windows OS installed on the NVR.

3. Run the Configuration Tool for the Analytics Kit.

4. Install the latest version the ACC software used at your site.

NOTE: To make use of the Analytics Kit for an NVR or Video Appliance after it has been configured, you must use the ACC software version 6.8.6.4 or later.

Installing the Analytics Kit into the NVR4-VAL or HD-NVR3-VAL

1. Make sure the recorder is turned off.
 - All network, power, and peripheral cables are disconnected from the recorder.
 - Use a static mat or static strap to ground yourself against static shock.
2. At the top of the recorder, unlock the latch release then lift and rotate the latch towards the back of the recorder.

The cover slides back and is released from the recorder body.

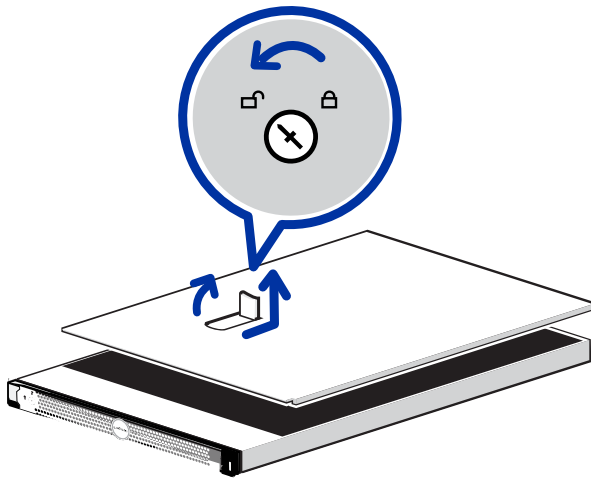

3. At the back of the recorder, locate the expansion card riser.

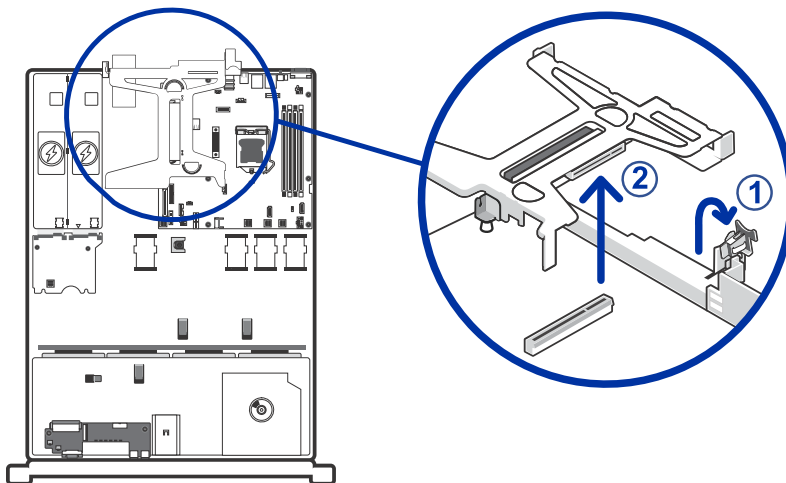

4. Lift and rotate the expansion card latch to open it.
5. Remove the expansion card riser by lifting it up from the riser connector.

6. Insert and press the NVR Analytics Kit into the appropriate expansion riser slot.

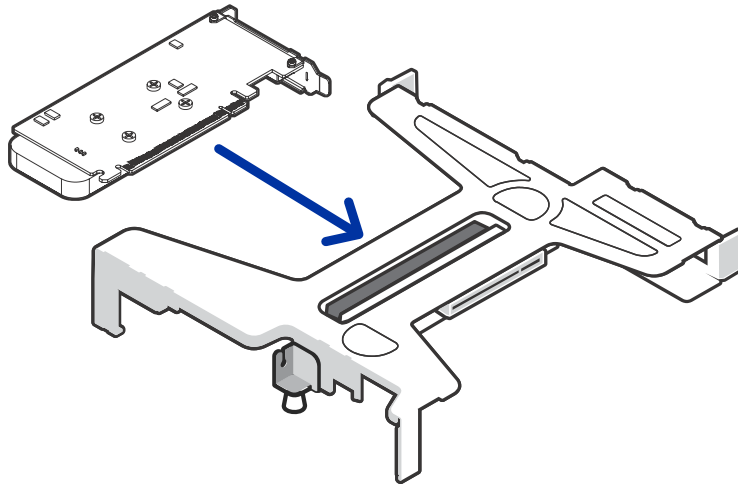

7. Push the expansion card riser back into place and close the expansion card latch.

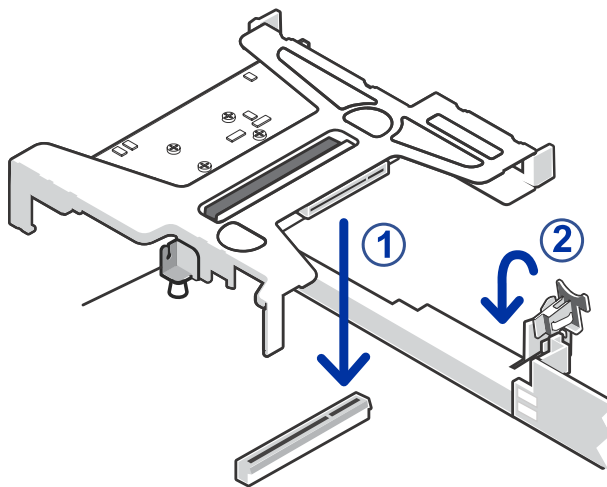

8. Close and lock the recorder cover.

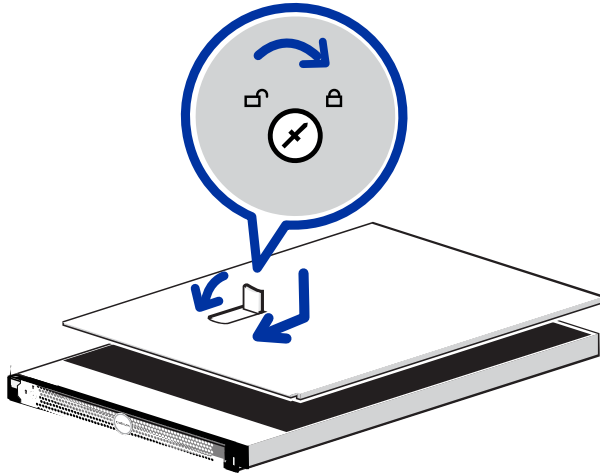

9. Reconnect all the cables and turn on the recorder.
10. Proceed to install the required Windows driver for the NVR Analytics Kit. See *Updating the Windows OS Driver and Configuring the NVR* on page 16.

Installing NVR Analytics Kit into the HD-NVR3-PRM or HD-NVR3-STD

1. Make sure the recorder is turned off.
 - All network, power and peripheral cables are disconnected from the recorder.
 - It is recommended that you use a static mat or static strap to ground yourself against static shock.
2. At the top of the recorder, unlock the latch release then lift and rotate the latch towards the back of the recorder.

The cover slides back and is released from the recorder body.

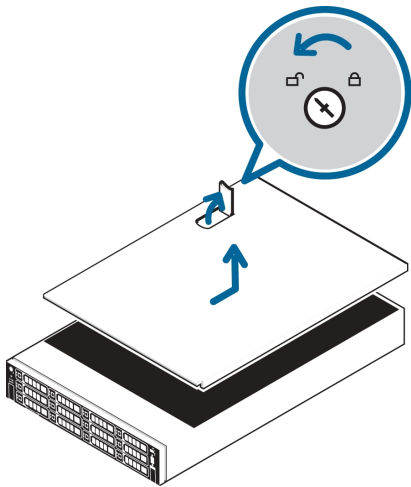

3. At the back of the recorder, locate where the Analytics Kit needs to be installed.

For HD-NVR3-PRM and STD, the Analytics Kit needs to be installed on riser 2 - slot 5 (the middle slot on the riser).

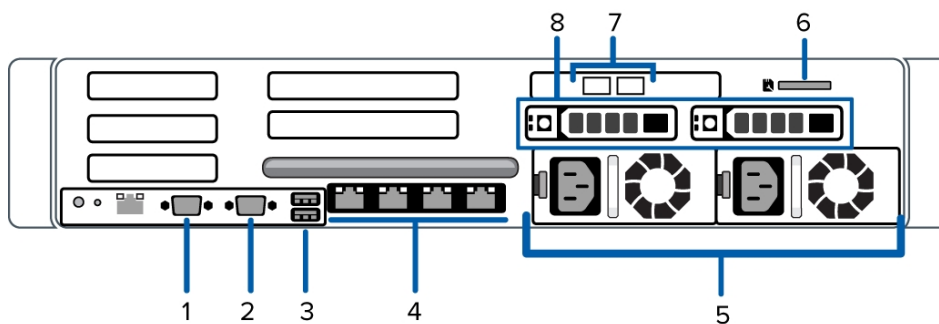

4. Lift the blue expansion card latch out of the recorder.

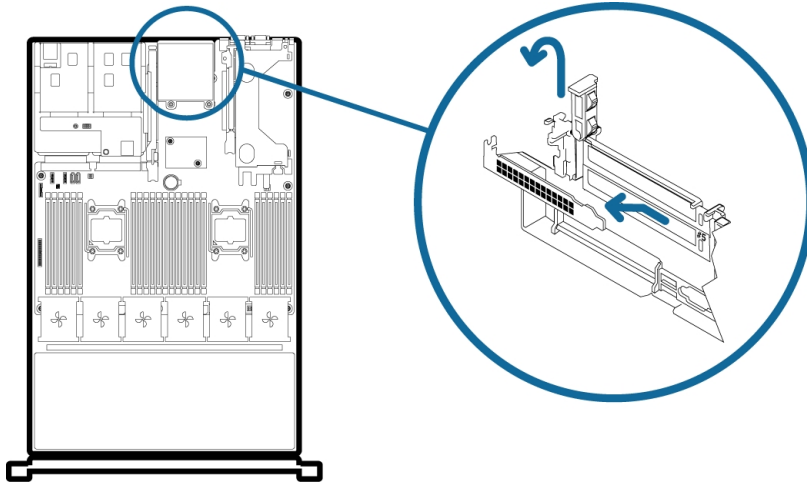

5. Remove the slot filler plate in riser 2 - slot 5.
6. Insert and press the Analytics Kit into the appropriate riser slot.

The Analytics Kit needs to be installed on riser 2 - slot 5.

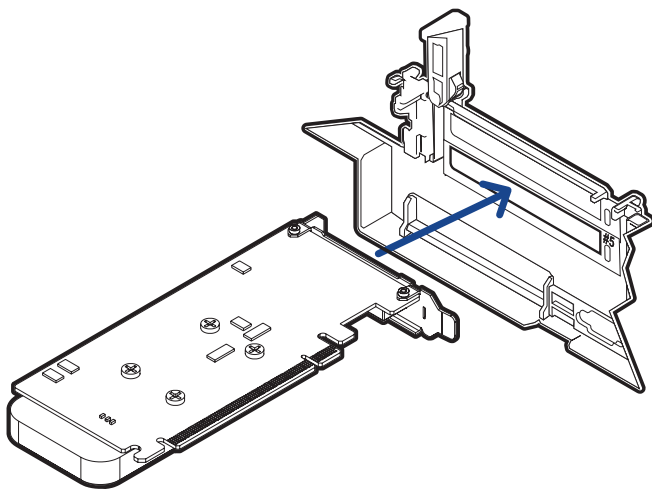

7. Push the blue expansion card latch back into place.

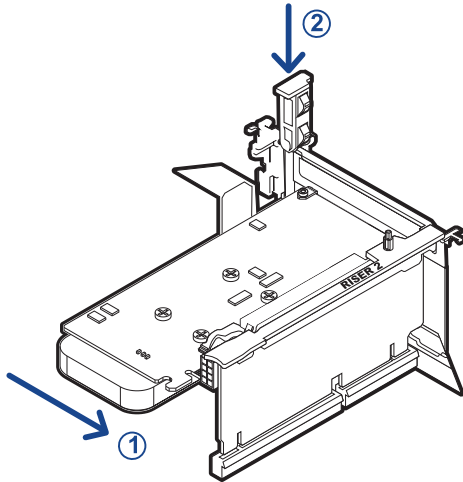

8. Close and lock the recorder cover.

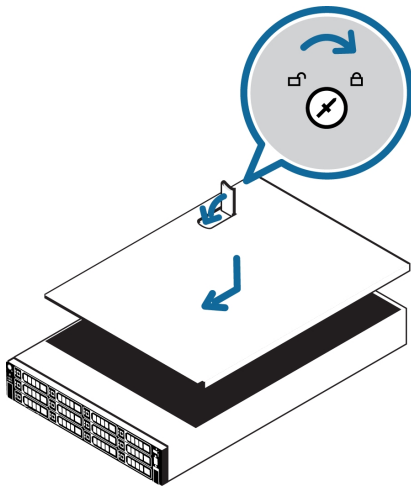

9. Reconnect all the cables and turn on the recorder.
10. Proceed to install the required Windows driver for the Analytics Kit. See *Updating and Configuring the NVR for Analytics* on page 15.

Installing the Analytics Kit into the HD-NVR2

You can install the Analytics Kit in an HD-NVR2 after the recorder has been upgraded to Windows 10. For instructions, download the *Windows 10 Operating System Upgrade for Avigilon NVR2 and AS1 Recorders* from the [Avigilon Technical Support website](#).

1. Make sure the recorder is turned off.
 - All network, power and peripheral cables are disconnected from the recorder.
 - It is recommended that you use a static mat or static strap to ground yourself against static shock.
2. At the top of the recorder, unlock the latch release then lift and rotate the latch towards the back of the recorder.

The cover slides back and is released from the recorder body.

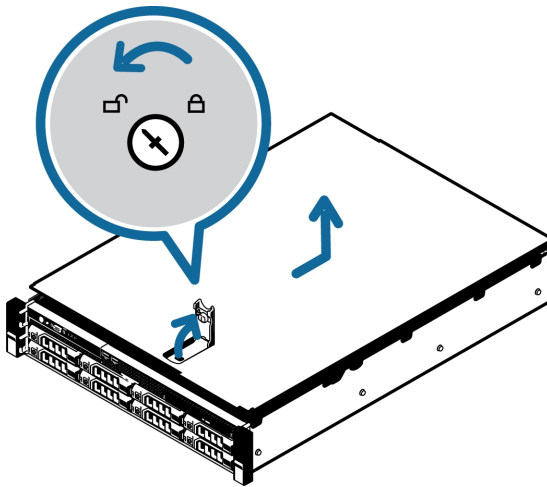

3. At the back of the recorder, locate where the Analytics Kit needs to be installed.
 - For HD-NVR2, the Analytics Kit needs to be installed on riser 2 - slot 2 (or the top slot on the riser).

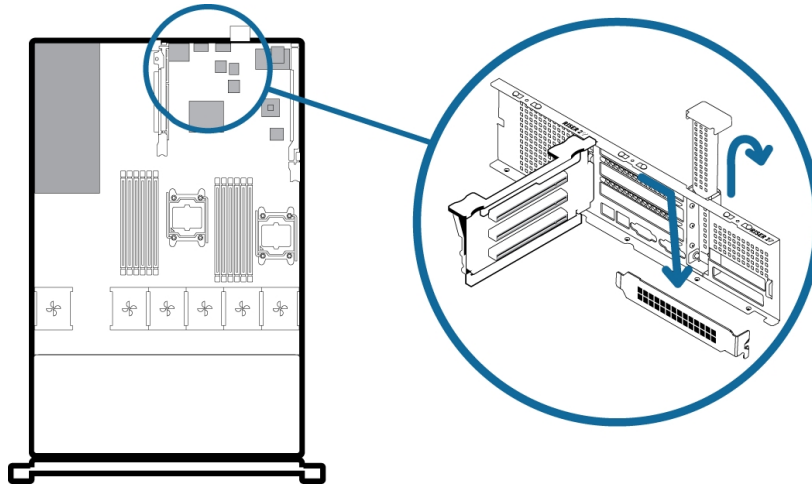

4. Lift the blue expansion card latch out of the recorder.
5. Remove the slot filler plate.
6. Insert and press the Analytics Kit into the appropriate riser slot.

The Analytics Kit needs to be installed on riser 2 - slot 2.

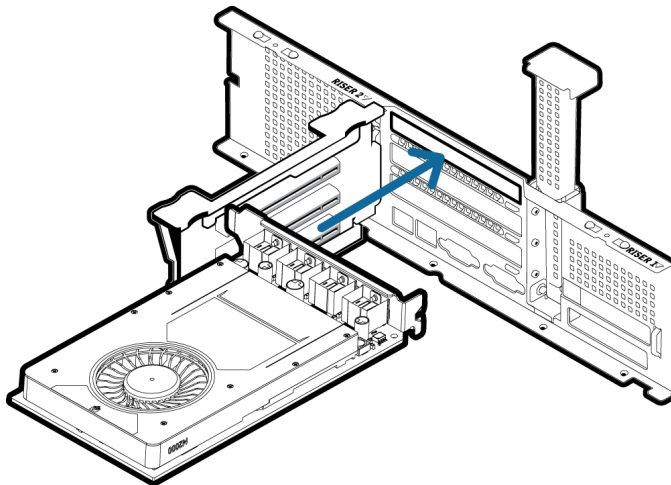

7. Push the blue expansion card latch back into place.

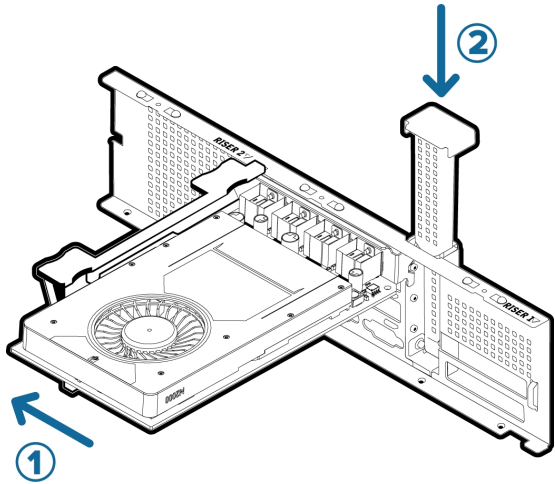

8. Close and lock the recorder cover.

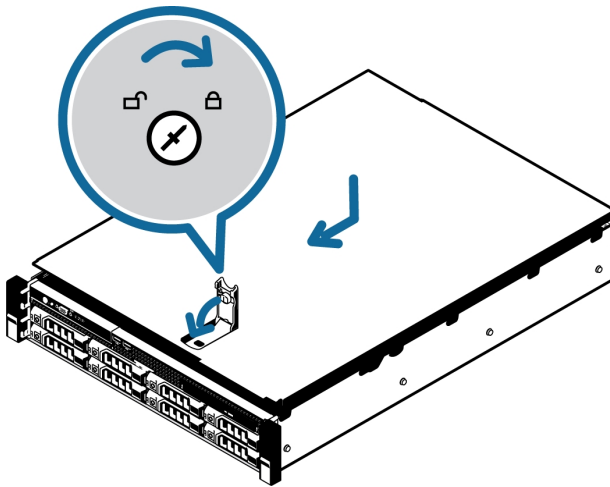

9. Reconnect all the cables and turn on the recorder.
10. Install the required Windows driver for the Analytics Kit. See *Updating and Configuring the NVR for Analytics* on the next page.

Updating and Configuring the NVR for Analytics

The USB flash drive provided with the NVR Analytics Kit contains verified software to update the Windows operating systems supported on the current range of available Avigilon NVRs. You must install the update software appropriate to the Windows OS on your NVR to automatically configure the NVR Analytics Kit to operate with the Avigilon Control Center software.

The USB flash drive contains the following folders:

- `../Server2016/` for the OS on the NVR4-PRM and NVR4-STD, which contains:
 - `nnn.nn-quadro-winserv-2016-2019-64bit-international-whql.exe`
- `../Server2012R2/` for the OS on the HD-NVR3-PRM, which contains:
 - `nnn.nn-quadro-winserv2008r2-2012-2012r2-64bit-international-whql.exe`
 - `Win8.1AndW2K12R2-KB3191564-x64.msu`
- `../Win10/` for the OS on the NVR4-VAL most NVR3-STD, NVR3-VAL models, and for any model of NVR previously running Windows 7 and upgraded to Windows 10, which contains:
 - `nnn.nn-quadro-desktop-notebook-win10-64bit-international-whql.exe`

Important: Before updating the Windows operating system driver on your NVR, check the Windows version currently running. If the NVR is using Windows Server 2012, you must update Windows PowerShell. See *Updating Windows PowerShell (Windows Server 2012 only)* below

Updating Windows PowerShell (Windows Server 2012 only)

Update Windows PowerShell if the operating system on your NVR appliance is Windows Server 2012R2 or Windows 7.

1. Insert the USB flash drive into the USB port on the NVR.



2. Windows Server 2012R2:
 - a. Navigate to the `../Server2012R2/` folder on the USB drive.
 - b. Double-click on **Win8.1AndW2K12R2-KB3191564-x64**.

Updating the Windows OS Driver and Configuring the NVR

Update the driver software for the version of the Windows operating system on your NVR:

1. Insert the USB flash drive into the USB port on the NVR if it is not already present.



2. From the USB flash drive, navigate to the folder for the operating system used on the NVR appliance:
 - Windows 10 (NVR4-VAL, NVR3-VAL, NVR3-STD)
 - a. Navigate to the `../Win10/` folder on the USB drive.
 - b. Right-click on `<nnn.nn-quadro-desktop-notebook-win10-64bit-international-whql.exe`
 - Windows Server 2016 (NVR4-PRM, NVR4-STD)
 - a. Navigate to the `../Server2016/` folder on the USB drive.
 - b. Right-click on `<nnn.nn-quadro-desktop-notebook-win10-64bit-international-whql.exe`
 - Windows Server 2012R2 (HD-NVR3-PRM)
 - a. Navigate to the `../Server2016/` folder on the USB drive.
 - b. Right-click on `nnn.nn-quadro-winserv2008r2-2012-2012r2-64bit-international-whql.exe`
3. Select **Run as administrator**
4. Right-click **GPU Configuration Tool.exe** and select **Run as administrator**.

Allow the Configuration Tool to run and finish. You will see several processing messages as the system is reconfigured for the new GPU provided with the Analytics Kit.

Note: When configuring the NVR Premium (Series 3) the message **System Rebranding Requested** also appears. No action is required.

The process takes under ten minutes. After it completes the NVR will automatically restart.

After the Analytics Kit has been installed and configured, you can download, install and run the latest version of the Avigilon Control Center software.

Troubleshooting the NVR Appliance Fans

On NVR STD or NVR PRM appliances after the NVR Analytics Kit has been installed and configured and the recorder restarted, check the fan speed. Normally, the fan speed should slow down and the fan noise noticeably drop shortly after powering on. If the fan noise does not decrease, open a PowerShell window and enter:

```
racadm reset
```

Installing the Analytics Kit into the 16 Port or 24 Port Video Appliance

Install the Analytics Kit for the Video Appliance (VMA-AS3-ANK) in any HD Video Appliance Pro 16 Port or 24 Port model to use the video analytics features of the Avigilon Control Center (ACC™) system.

The Analytics Kit consists of the GPU preinstalled in a mounting bracket that drops into place in the chassis and is secured in place with four screws.

1. Make sure the appliance is turned off, and:
 - All network, power and peripheral cables are disconnected from the recorder.
 - It is recommended that you use a static mat or static strap to ground yourself against static shock.
2. Remove the top of the appliance by unscrewing the two screws at the back of the appliance, sliding the top backward to release it from the front bezel and lifting it off.

Tip: You can pull the cover back using the tabs that are used by the screws to connect the cover to the chassis.

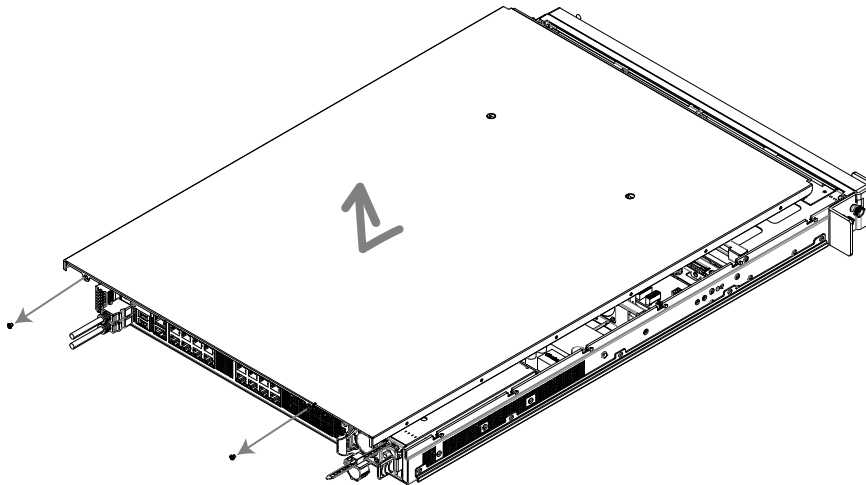

3. The Analytics Kit is installed in the open area towards the back of the chassis next to the internal power supply:

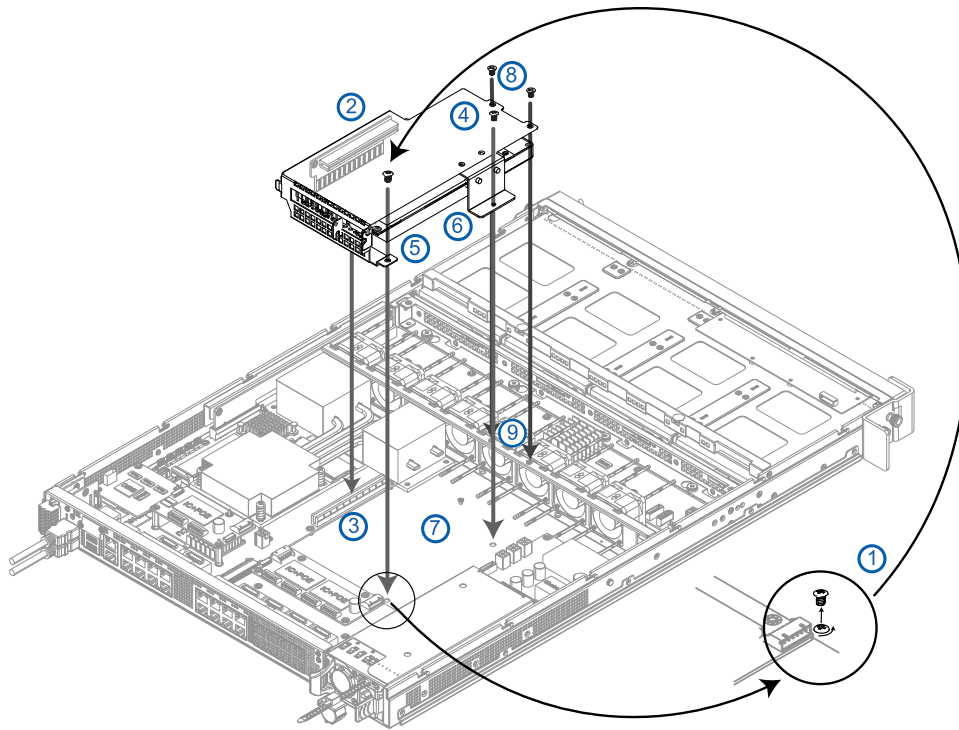

- a. Remove the round-headed screw (1) from the bottom of the chassis and set aside.
 - b. Place the Analytics Kit into the chassis, ensuring the connector (2) fits securely into the slot (3).
 - c. Fasten the Analytics Kit to the chassis with the screw (1) and the three screws provided with the kit:
 1. Insert the round-headed screws (1) and (4) through the holes on the mounting bracket tabs (5) and (6) into the corresponding threaded holes on the bottom of the chassis (7).
 2. Insert and tighten the two flat-headed screws (8) to included with the kit into the threaded holes (9) on the crossbar.
4. Reattach the top of the appliance by placing the top on the appliance just behind the front bezel, sliding the top forwards, and screwing the top back onto the appliance.
 5. Install the required Windows driver for the Analytics Kit. See *Updating and Configuring the 16 Port or 24 Port Video Appliance for Analytics* on the next page.

Updating and Configuring the 16 Port or 24 Port Video Appliance for Analytics

The USB flash drive provided with the Video Appliance Analytics Kit (VMA-AS3-ANK) contains the verified Windows 10 driver you must install on the HD Video Appliance Pro 16 Port or 24 Port model. After it is installed, Avigilon Analytics functionality will be automatically configured on the appliance to operate with the Avigilon Control Center software.

The USB flash drive contains the `../Win10/` folders, which contains `nnn.nn-quadro-desktop-notebook-win10-64bit-international-whql.exe`

1. Insert the USB flash drive into the USB port on the appliance.



2. From the USB flash drive, navigate to the `../Win10/` folder.
3. Right-click on `<nnn.nn-quadro-desktop-notebook-win10-64bit-international-whql.exe`
4. Select **Run as administrator**
5. Right-click **GPU Configuration Tool.exe** and select **Run as administrator**.

Allow the Configuration Tool to run and finish. You will see the message **System Rebranding Requested**, and several processing messages as the system is reconfigured for the new GPU provided with the NVR Analytics Kit. The process takes under ten minutes. After it completes the NVR appliance will automatically restart.

Limited Warranty and Technical Support

Avigilon warranty terms for this product are provided at [avigilon.com/warranty](https://www.avigilon.com/warranty).

Warranty service and technical support can be obtained by contacting Avigilon Technical Support: [avigilon.com/contact-us/](https://www.avigilon.com/contact-us/).