

## AXIS Q1765-LE Network Camera

Full featured, all integrated bullet-style outdoor-ready camera.



- > 18x zoom and autofocus
- > Built-in IR illumination
- > Bullet-style
- > Slim design and low-weight
- > Outdoor-ready

The bullet-style and outdoor-ready AXIS Q1765-LE Network Camera is especially adapted for installation on buildings, for monitoring entrances and exits, parking lots, toll booths, service stations and for general city surveillance purposes.

AXIS Q1765-LE Network Camera delivers exceptional image quality including SMPTE-compliant HDTV 1080p and it provides multiple, individually configurable H.264 and Motion JPEG video streams.

It incorporates new long-life LED (850 nm) technology that is highly power-efficient. Adjustable in angle and intensity, the built-in IR solution offers easy configuration optimizing for the scene. The four auto adjusting IR LEDs cover up to 15 m (50 ft) in the widest field of view and up to 40 m (130 ft) when the camera is in full tele view.

It offers motorized optical zoom up to 18x and autofocus, which makes the camera particularly useful in city surveillance installations, where it can cover great dis-

tances providing both wide overviews as well as detailed images for identification purposes.

AXIS Q1765-LE with its bullet-style and slim design offers ease of installation capabilities with one-cable installation. It has low, environmental-friendly power consumption, supplied by standard Power over Ethernet (IEEE 802.3af).

The compact and outdoor-ready AXIS Q1765-LE is a lightweight yet tough camera which is both IP66- and NEMA 4X-rated. The Arctic Temperature Control capability allows reliable start-up in any temperatures from -40 °C to 50 °C (-40 °F to 122° F), making it perfect for installations in places with challenging weather.



### Powerful zoom with high image detail

AXIS Q1765-LE offers very high image detail with its HDTV 1080p performance in compliance with the SMPTE 274M standard regarding a 1920x1080 pixel resolution, 25/30 frames per second, HDTV color fidelity and a 16:9 format. Since HDTV 1080p provides more than dou-

ble the number of pixels as HDTV 720p (1280x740p), the combination of HDTV 1080p performance and 18x optical zoom allows AXIS Q1765-LE to catch details at longer distances than a camera with HDTV 720p and the same zoom factor.



The image to the right is taken with a digital single-lens reflex camera with a 50 mm lens – thus representing the view of the human eye. The image to the left is a snapshot from AXIS Q1765-LE in 18x zoomed-in view where the license plate of a car 275 m (900 ft.) away can be read.

### Day/night functionality and IR illumination

The day/night functionality in AXIS Q1765-LE is useful for surveillance in indoor or outdoor environments with changing lighting conditions. The day/night functionality involves an automatically removable infrared-cut filter in the cameras. The filter is on during daytime or bright conditions, enabling the cameras to produce colors as the human eye sees them. In nighttime or low-light conditions, the filter is removed to enable the

cameras to take advantage of invisible near-infrared light from available light sources to produce good quality black and white images. The functionality allows the cameras to extend their usefulness in low-light conditions and enables IR (infrared) illuminators to be used to further improve video quality in dark environments. AXIS Q1765-LE has built-in IR illuminators and is ideal for surveillance in complete darkness.



The above images are snapshots from AXIS Q1765-LE mounted indoors in a 30 m (98 ft) long hallway. The image to the left is the camera view in Corridor Format in wide view and day mode at 600 lux. The image in the middle, also in Corridor Format in wide view, is taken in night mode at 0 lux with IR illumination on and shows a person at a 2 m distance from camera. In the image to the right, the AXIS Q1765-LE is in Corridor Format and night mode at 0 lux with IR illumination on. The camera is in full tele view at 18x zoom and the person is at a 30 m.

## Dimensions

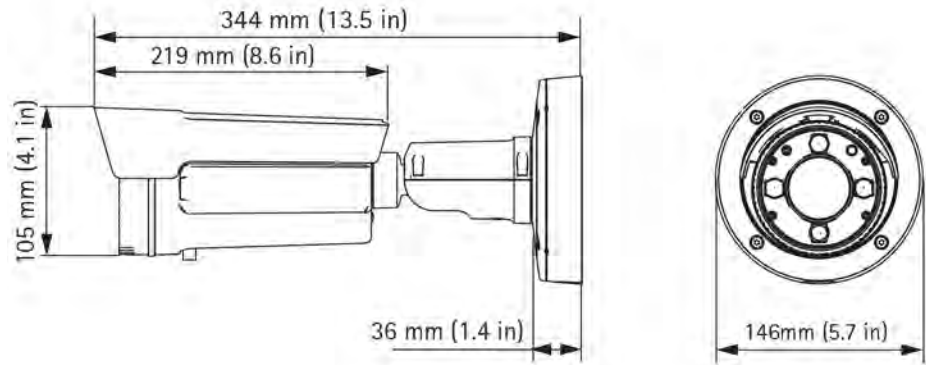

## Optional accessories

1. *AXIS T98A17-VE Surveillance Cabinet*
2. *AXIS T91A47 Pole Mount 60 mm–110 mm*
3. *AXIS T91A47 Pole Mount 110 mm–400 mm*
4. *AXIS T94P01B Corner Bracket*
5. *AXIS T8640 Ethernet over Coax Adapter PoE+*
6. *AXIS T8604 Media Converter Switch*
7. *AXIS T8120 Midspan 15 W 1-port*
8. *AXIS T8129 PoE Extender*
9. *AXIS Multicable A I/O Audio 5 m and AXIS Multicable A I/O Audio 1 m*



## Technical Specifications – AXIS Q1765-LE Network Camera

<b>Models</b>	AXIS Q1765-LE Network Camera	
<b>Camera</b>		
<b>Image sensor</b>	1/2.9" progressive scan RGB CMOS	
<b>Lens</b>	f=4.7–84.6 mm, F1.6–2.8, Autofocus, Automatic day/night Horizontal angle of view: 59° to 4°	
<b>Day and night</b>	Automatically removable infrared-cut filter	
<b>Minimum illumination</b>	Color: 0.5 lux at 30 IRE F1.6 B/W: 0.04 lux at 30 IRE F1.6 (0 lux with IR illumination on)	
<b>Shutter time</b>	1/28000 s to 2 s	
<b>Video</b>		
<b>Video compression</b>	H.264 Mainline and Baseline Profiles (MPEG-4 Part 10/AVC) Motion JPEG	
<b>Resolutions</b>	1920x1080 (HDTV 1080p) to 320x180	
<b>Frame rate</b>	H.264/Motion JPEG: Up to 30/25 fps (60/50 Hz) in all resolutions	
<b>Video streaming</b>	Multiple, individually configurable streams in H.264 and Motion JPEG Controllable frame rate and bandwidth VBR/CBR H.264	
<b>Image settings</b>	Manual shutter time, Compression, Color, Brightness, Sharpness, White balance, Exposure control, Exposure zones, Backlight compensation, Fine tuning of behavior at low light, Rotation, Text and image overlay, 3D privacy mask, Day/night shift level, Axis' Corridor Format	
<b>Pan/Tilt/Zoom</b>	18x optical zoom and 12x digital zoom Preset positions	
<b>Audio</b>		
<b>Audio streaming</b>	Two-way	
<b>Audio compression</b>	AAC-LC 8/16 kHz, G.711 PCM 8 kHz, G.726 ADPCM 8 kHz Configurable bit rate	
<b>Audio input/output</b>	Requires multi-connector cable (not included) for external microphone input or line input and line output	
<b>Network</b>		
<b>Security</b>	Password protection, IP address filtering, HTTPS <sup>a</sup> encryption, IEEE 802.1X <sup>a</sup> network access control, Digest authentication, User access log	
<b>Supported protocols</b>	IPv4/v6, HTTP, HTTPS <sup>a</sup> , SSL/TLS <sup>a</sup> , QoS Layer 3 DiffServ, FTP, CIFS/SMB, SMTP, Bonjour, UPnP <sup>TM</sup> , SNMPv1/v2c/v3 (MIB-II), DNS, DynDNS, NTP, RTSP, RTP, TCP, UDP, IGMP, RTCP, ICMP, DHCP, ARP, SOCKS	
<b>System integration</b>		
<b>Application Programming Interface</b>	Open API for software integration, including VAPIX <sup>®</sup> and AXIS Camera Application Platform; specifications at <a href="http://www.axis.com">www.axis.com</a> AXIS Video Hosting System (AVHS) with One-Click Camera Connection. ONVIF Profile S, specification at <a href="http://www.onvif.org">www.onvif.org</a>	
<b>Intelligent video</b>	Video motion detection, Active Gatekeeper, Active tampering alarm, Audio detection, AXIS Camera Application Platform enabling installation of additional applications	
<b>Event triggers</b>	Intelligent video, External input, Edge storage events	
<b>Event actions</b>	File upload: FTP, HTTP, network share and email Notification: email, HTTP and TCP External output activation Video and audio recording to edge storage Pre- and post-alarm video buffering	
<b>Data streaming</b>	Event data	
<b>Built-in installation aids</b>	Pixel counter	
<b>General</b>		
<b>Casing</b>	IP66- and NEMA 4X-rated, impact-resistant aluminum enclosure Color: white NCS S 1002-B	
<b>Memory</b>	256 MB RAM, 128 MB Flash	
<b>Power</b>	Power over Ethernet IEEE 802.3af; max 12.95 W 8–28 V DC max 15.2 W, 20–24 V AC max 22.0 VA	
<b>Connectors</b>	RJ45 10BASE-T/100BASE-TX PoE DC Power connector Multi-connector (not included): 2 configurable alarm inputs/outputs, mic in, line mono input, line mono output (e.g. to active speaker)	
<b>Edge storage</b>	MicroSD/microSDHC/microSDXC slot supporting memory card up to 64 GB (card not included) Support for recording to network share (network-attached storage or file server)	
<b>Operating conditions</b>	–40 °C to 50 °C (–40 °F to 122 °F) Humidity 10–100% RH (condensing)	
<b>Approvals</b>	EN 55022 Class B, EN 61000-3-2, EN 61000-3-3, EN 61000-6-1, EN 61000-6-2, EN 55024, EN 50121-4, FCC Part 15 Subpart B Class A, ICES-003 Class B, VCCI Class A, C-tick AS/NZS CISPR 22, KCC KN22 Class A, KN24, IEC/EN/UL 60950-22	
<b>Weight</b>	1.8 kg (4.0 lb) including the bracket	
<b>Included accessories</b>	Connector kit, Installation Guide, Mini CD with installation tools, Recording software and User's Manual, Windows decoder 1-user license, Allen key	
<b>Optional accessories</b>	AXIS T98A17-VE Surveillance Cabinet AXIS Multicable A I/O Audio 5 m Power: AXIS T8120 Midspan 15 W 1-port or AXIS T8129 PoE Extender Media converters: AXIS T8640 Ethernet over Coax Adapter PoE+ or AXIS T8604 Media Converter Switch Mounts: AXIS T91A47 Pole Mount 60 mm–110 mm or AXIS T91A47 Pole Mount 110 mm–400 mm or AXIS T94P01B Corner Bracket	
<b>Video management software</b>	AXIS Camera Companion (included), AXIS Camera Station and video management software from Axis' Application Development Partners (not included). For more information, see <a href="http://www.axis.com/products/video/software">www.axis.com/products/video/software</a>	
<b>Warranty</b>	Axis 3-year warranty, see <a href="http://www.axis.com/warranty">www.axis.com/warranty</a>	

a. This product includes software developed by the OpenSSL Project for use in the OpenSSL Toolkit. ([www.openssl.org](http://www.openssl.org)), and cryptographic software written by Eric Young ([ey@cryptsoft.com](mailto:ey@cryptsoft.com)).

More information is available at [www.axis.com](http://www.axis.com)