

LBC 3482/00 Horn Loudspeaker

www.boschsecurity.com



BOSCH
Invented for life



- ▶ High efficiency driver
- ▶ Excellent speech reproduction
- ▶ Provision for inside mounting of the optional line/loudspeaker supervision board
- ▶ Water-and dust protected to IP 65
- ▶ EN 54-24 certified

Bosch high-efficiency horn loudspeakers provide excellent speech reproduction and sound distribution for a wide scope of outdoor applications. They are ideal for sports grounds, parks, exhibitions, factories and swimming pools.

The LBC 3482/00 is a circular 25 W horn loudspeaker, measuring 355 mm (14 in) in diameter. They are made from aluminum. The edges of the horns are covered with a PVC profile for protection against impact damage. They are light grey (RAL 7035), and are water and dust protected.

Voice alarm loudspeaker

The LBC 3482/00 is designed for use in voice alarm systems and is compliant with emergency standards. The horn loudspeaker has built-in protection to ensure that, in the event of a fire, damage to the loudspeaker does not result in failure of the circuit to which it is connected. In this way, system integrity is maintained; ensuring loudspeakers in other areas can still be used to inform people of the situation. The horn loudspeaker has a ceramic terminal block, thermal fuse and heat resistant, high-temperature wiring. They have provision for inside mounting the optional line/loudspeaker supervision boards.

Functions

The rear cover on the horn is made from self-extinguishing ABS (acc. to class UL 94 V0). The connection cable is fed out through a cable gland (PG 13.5) in rear cover. For loop through connection, the rear cover is fitted with a second hole (covered as standard supplied).

These integrated horns are also available as separate horn and driver, allowing installing any combination of horn and driver. See order information for the type numbers.

Certifications and approvals

All Bosch loudspeakers are designed to withstand operating at their rated power for 100 hours in accordance with IEC 268-5 Power Handling Capacity (PHC) standards. Bosch has also developed the Simulated Acoustical Feedback Exposure (SAFE) test to demonstrate that they can withstand two times their rated power for short durations. This ensures extra reliability under extreme conditions, leading to higher customer satisfaction, longer operation life, and much less chance of failure or performance deterioration.

Safety	acc. to EN 60065
Water and dust protection	acc. to IEC 60529, IP 65
Emergency	acc. to EN 54-24 / BS 5839-8 / EN 60849
Wind-force	acc. to NEN 6702: 2007 + A1: 2008, Bft11

Region	Certification
Europe	CE
	CPD
Poland	CNBOP

Installation/configuration notes

Simple Power Setting

The horn has a three-way terminal block with screw connection (including earth). Three primary taps are provided on the matching transformer to allow selection of nominal full-power, half-power or quarter-power radiation (in 3 dB steps).

Mounting

The horn loudspeakers are supplied, complete with sturdy adjustable steel mounting brackets, allowing the sound beam to be accurately directed.

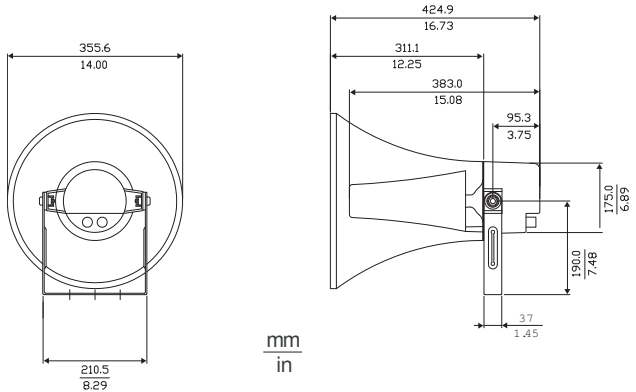

Dimensions in mm (in)

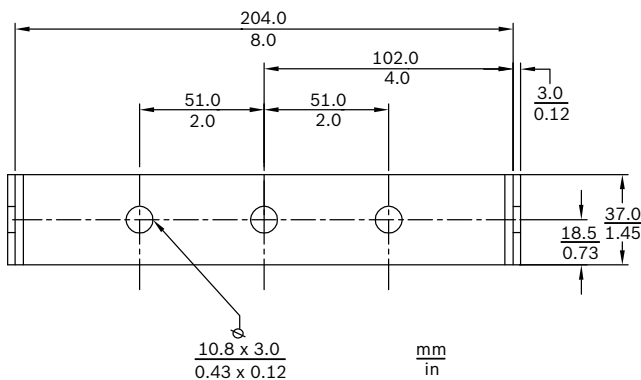

Bracket dimensions

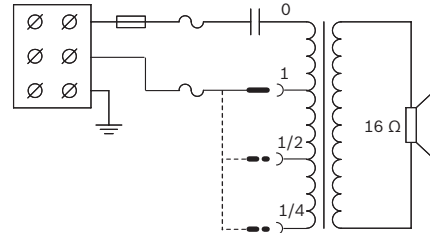

Circuit diagram

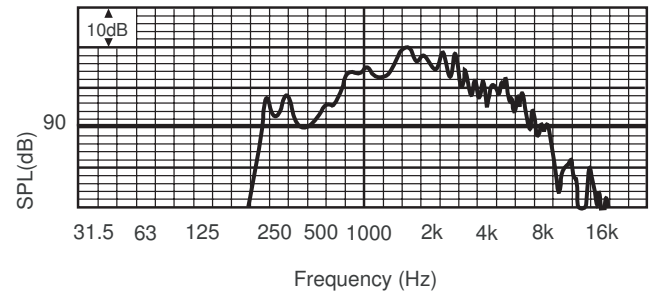

Frequency response

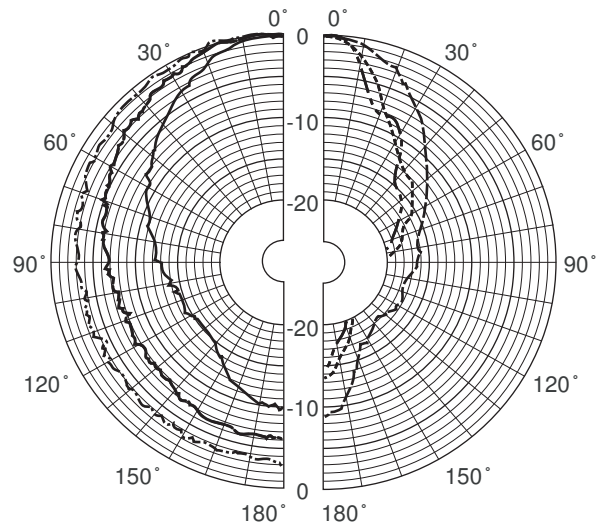

- 250 Hz
- 500 Hz
- 1000 Hz
- 2000 Hz
- 4000 Hz
- 8000 Hz

Polar diagram (measured in pink noise)

Octave band sensitivity*

	Octave SPL 1W/1m	Total octave SPL 1W/1m	Total octave SPL Pmax/1m
125 Hz	60.1	-	-
250 Hz	86.6	-	-
500 Hz	100.2	-	-
1000 Hz	106.9	-	-
2000 Hz	104.1	-	-

4000 Hz	99.4	-	-
8000 Hz	87.8	-	-
A-weighted	-	100.1	113.0
Lin-weighted	-	99.8	111.8

Octave band opening angles

	Horizontal	Vertical	
125 Hz	-	-	
250 Hz	360	360	
500 Hz	120	120	
1000 Hz	75	75	
2000 Hz	43	43	
4000 Hz	25	25	
8000 Hz	22	22	

Acoustical performance specified per octave

- (all measurements are done with a pink noise signal; the values are in dB SPL)

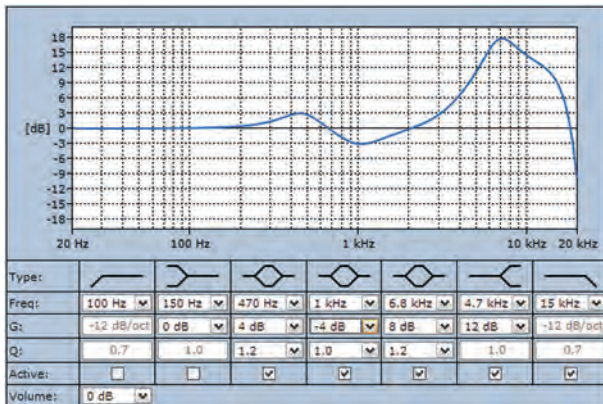

Specified active equalization, required for EN54-24

Parts included

Quantity	Component
1	LBC 3482/00 Horn Loudspeaker
1	PG 13.5 cable gland (fitted)

Technical specifications

Electrical*

Maximum power	37.5 W
Rated power	25 / 12.5 / 6.25 W
Sound pressure level at 25 W / 1 W (1 kHz, 1 m)	121 dB / 107 dB (SPL)
Effective frequency range (-10 dB)	550 Hz to 5 kHz

Opening angle at 1 kHz/4 kHz (-6 dB)	70° / 25°
Rated voltage	100 V
Rated impedance	400 ohm
Connector	Screw terminal block

* Technical performance data acc. to IEC 60268-5

Mechanical

Dimensions (L x Dmax)	425 x 355 mm (16.7 x 14 in)
Weight	3.6 kg (8 lb)
Color	Light grey (RAL 7035)
Cable diameter	6 mm to 12 mm (0.24 in to 0.47 in)

Environmental

Operating temperature	-25 °C to +55 °C (-13 °F to +131 °F)
Storage temperature	-40 °C to +70 °C (-40 °F to +158 °F)
Relative humidity	<95%

Other parameters are available in CNBOP test report nr 4786/BA/10.



1438

Bosch Security Systems BV
Kapittelweg 10, 4827 HG Breda, The Netherlands
10
1438-CPD-0192

EN 54-24:2008

Loudspeaker for voice alarm systems
for fire detection and fire alarm systems for buildings

Horn Loudspeaker 25 W
LBC3482/00
Type B

Ordering information

LBC 3482/00 Horn Loudspeaker

25 W, aluminum, circular
Order number **LBC3482/00**

Accessories

LBC 3478/00 Horn, 14" without Driver

aluminum, suitable for use with driver units LBC 3472/00, LBC 3473/00, and LBC 3474/00
Order number **LBC 3478/00**

LBC 3479/00 Horn, 20" without Driver

aluminum, suitable for use with driver units LBC 3472/00, LBC 3473/00, and LBC 3474/00
Order number **LBC 3479/00**

LBC 3472/00 Driver Unit

25 W, 100 V
Order number **LBC 3472/00**

LBC 3473/00 Driver Unit

35 W, 100 V
Order number **LBC 3473/00**

LBC 3474/00 Driver Unit

50 W, 100 V
Order number **LBC3474/00**

Represented by:

Americas:

Bosch Security Systems, Inc.
12000 Portland Avenue South
Burnsville MN 55337, USA
Phone: +1-800-392-3497
Fax: +1-800-955-6831
audiosupport@us.bosch.com
www.boschsecurity.com

Europe, Middle East, Africa:

Bosch Security Systems B.V.
P.O. Box 80002
5617 BA Eindhoven, The Netherlands
Phone: + 31 40 2577 284
Fax: +31 40 2577 330
emea.securitysystems@bosch.com
www.boschsecurity.com

Asia-Pacific:

Robert Bosch (SEA) Pte Ltd, Security Systems
11 Bishan Street 21
Singapore 573943
Phone: +65 6571 2808
Fax: +65 6571 2699
apr.securitysystems@bosch.com
www.boschsecurity.asia

China:

Bosch (Shanghai) Security Systems Ltd.
201 Building, No. 333 Fuquan Road
North IBP
Changning District, Shanghai
200335 China
Phone +86 21 22181111
Fax: +86 21 22182398
www.boschsecurity.com.cn

America Latina:

Robert Bosch Ltda Security Systems Division
Via Anhanguera, Km 98
CEP 13065-900
Campinas, Sao Paulo, Brazil
Phone: +55 19 2103 2860
Fax: +55 19 2103 2862
al.securitysystems@bosch.com
www.boschsecurity.com