

DINION AN 5000

www.boschsecurity.com



BOSCH
Invented for life



- ▶ Ultra high resolution 960H sensor
- ▶ High Dynamic Range to see bright and dark details simultaneously
- ▶ Detail enhancement
- ▶ Bilinx communication for remote set-up and control
- ▶ Easy to install

The DINION 5000 family combines high resolution with high dynamic range in a true day/night analog camera. The high performance 960H 1/3-inch CCD sensor with a resolution of 720TVL, the high dynamic range engine, and the advanced image processing technology combine together to provide a detailed image with outstanding accuracy in color reproduction even under harsh lighting conditions. True day/night performance ensures the highest image quality possible at any time, day or night. The camera is easy to install and offers the best solution for demanding scene conditions.

System overview

The camera is supplied ready to operate – simply attach the separately available lens, connect video and then power. Six distinct pre-programmed operational modes are stored in the camera. Recall the mode that suits your application for optimized performance. The lens wizard ensures accurate back-focusing for perfectly sharp pictures at all times. For especially challenging situations where fine tuning or special settings are required, the camera parameters can be individually set using the control buttons on the side of the camera and an Onscreen Display (OSD).

Functions

Detail in extreme lighting

In harsh lighting, the difference between the brightest and the darkest parts of a scene can be extreme. To produce a clear picture in these conditions, the CCD sensor in the camera generates two images; one long exposure to resolve details in the scene's darkest areas, and one short exposure to resolve details in the scene's brightest areas. The advanced image processing technology in the camera combines these dual shutter images, mixing pixels from each exposure to produce the most detailed image possible. The superior wide dynamic range for all lighting conditions reveals details previously unseen.

Day/Night mode

The day/night mode provides enhanced night viewing by increasing the IR sensitivity. The IR filter can switch from color to monochrome automatically by either sensing the illumination level or via the alarm input. The filter can be switched manually via the alarm input, through the camera menu or via the Bilinx coaxial control interface. An internal through-the-lens IR detector enhances the monochrome mode stability, as it prevents reverting to the color mode when IR illumination is dominant. IR contrast is also measured and used to handle reflected IR light in outdoor scenes.

Ease of installation

The lens wizard helps focus the lens at the maximum opening to ensure proper back-focus is maintained throughout the 24-hour cycle. No special tools or filters are required.

Six independent, pre-programmed operating modes support typical applications, but are fully programmable for individual situations. Switching between modes is easy via Bilinx or the external alarm input.

Several other features are available that make installation easy:

- Power and alarm cable connectors which can be removed even when the camera is mounted.
- A built-in test pattern generator produces signals to test and fault-find cables.
- A multi-language On-Screen Display (OSD).
- A high efficiency power supply improves maximum operating temperature

Cable compensation is used to avoid the need for amplifiers in long distance coaxial connections up to 1000 m (3000 ft). It can prevent the image quality degradation caused by signal losses from long cable lengths.

Bilinx technology

Bilinx is a bidirectional communication capability embedded in the video signal of this camera. Installers can check status, change camera settings and even update firmware from virtually anywhere along the video cable. Bilinx reduces service and installation time, provides for more accurate set-up and adjustment, and improves overall performance. In addition, Bilinx uses the standard video cable to transmit alarm and status messages, providing superior performance without additional installation steps.

Ideal picture performance

There are many settings available to help fine-tune the picture performance to match your installation environment. These include:

- Smart BLC – automatically and dynamically compensates for strong backlight
- Peak White Invert – reduces glare from highlight areas
- Contrast and sharpness – enhance details in bright or misty scenes
- SensUp – sensitivity is dramatically enhanced by a factor of 10
- Default shutter – improves the motion performance in auto exposure mode
- Dynamic noise reduction – dynamically reduces noise in the picture

Privacy masking

Fifteen different privacy zones allow specific parts of a scene to be blocked. Pre-program any part of the scene to be masked.

Video Motion Detection

The built-in video motion detector allows you to select four programmable areas with sensitivity thresholds. When motion is detected, alarms can be displayed in the video signal, the output relay can be closed or an alarm message can be transmitted via Bilinx.

Typical applications:

- Entrance foyer or lobby with glare
- Outdoor perimeters
 - low light
 - IR light
- Traffic monitoring
 - highway
 - traffic intersections
 - emergency response coordination
- Tunnels
- Car parks (outdoor)
- Restricted access locations such as:
 - prisons
 - ports / freight terminals
 - military facilities
 - border control and homeland
- Casino and gambling centers

Certifications and approvals

Standards	FCC Part15 Subpart B, Class B
	EN 55022 class B
	EN61000-3-2
	EN61000-3-3,
	EN 50130-4
	EN 50121-4
	Camera with 500 g (1.1 lbs) lens according to IEC 60068-2-6
VBN-5085-C11/ VBN-5085-C21	EN60950-1, UL60950-1 (2 ND edition), CSA C22.2 No. 60950-1-07 (2 ND edition)
VBN-5085-C51	EN60950-1
Product certifications	CE, FCC, UL, cUL, C-tick
Marks	CE, cULus, WEEE, PADS, RCM and China RoHS
Region	Certification
Europe	CE
USA	UL
	FCC
Canada	CSA

Installation/configuration notes

Dimensions

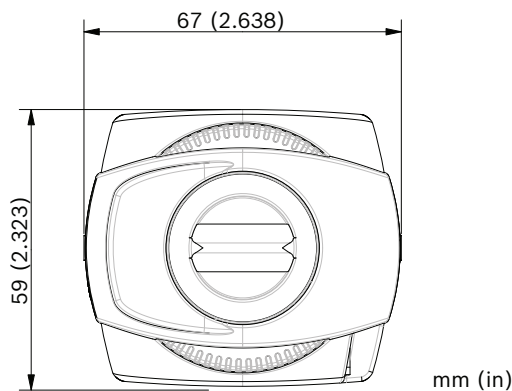
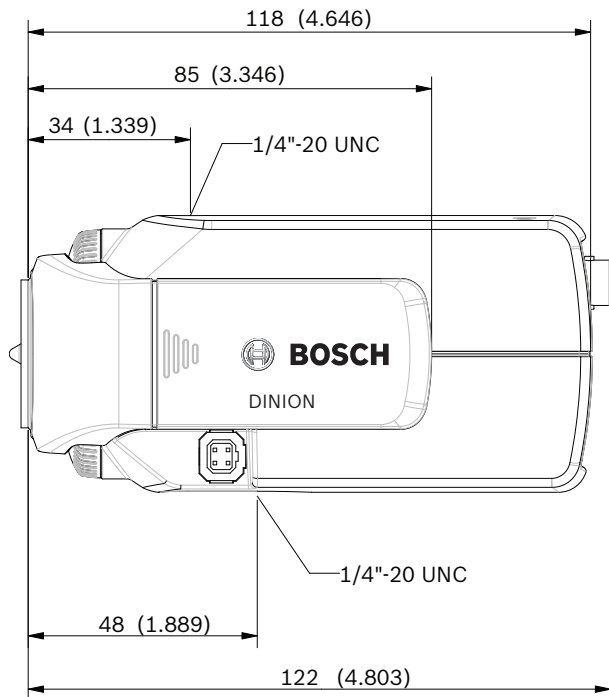

Technical specifications

Electrical

Model No.	Rated Voltage	Rated Frequency
VBN-5085/11	12 VDC / 24 VAC	50 Hz
VBN-5085/21	12 VDC / 24 VAC	60 Hz
VBN-5085/51	230 VAC	50 Hz
Power Consumption	360 mA (12 VDC) 330 mA (24 VAC) 60 mA (230 VAC)	

Image Sensor	960H, 1/3" DS CCD, sensor resolution 720TVL, WDR dual shutter
System	PAL or NTSC
Total pixels (H x V)	1020 x 596 (PAL) 1020 x 508 (NTSC)
Effective pixels (H x V)	976 x 582 (PAL) 976 x 494 (NTSC)

Sensitivity (3200K, scene reflectivity 89%, F1.2)

	Full video (100 IRE)	Usable picture (50 IRE)	Usable picture (30 IRE)
Color	0.5 lx (0.0465 fc)	0.09 lx (0.00837 fc)	0.04 lx (0.00372 fc)
Color + SensUp 10x	0.05 lx (0.00465 fc)	0.009 lx (0.000837 fc)	0.004 lx (0.000372 fc)
Monochrome	0.2 lx (0.0186 fc)	0.04 lx (0.00372 fc)	0.02 lx (0.00186 fc)
Monochrome SensUp 10x	0.02 lx (0.00186 fc)	0.004 lx (0.000372 fc)	0.002 lx (0.000186 fc)

Signal-to-Noise Ratio	>54 dB
Video Output	Composite video 1 Vpp, 75 ohm
Synchronization	Internal, Line Lock
Shutter	Auto (1/50 [1/60] to 1/100000) selectable, fixed, flickerless, default
Sensitivity Up	Adjustable from Off up to 10x
Day/Night	Color, Mono, Auto
Dynamic Engine	XF-Dynamic, HDR, Smart BLC
Dynamic Range	94 dB (WDR)
Dynamic Noise Reduction	2D-NR, 3D-NR
AGC	AGC On or Off (0 – 40 dB) selectable
Smart BLC	On/Off
Peak White Invert	On/Off
White Balance	ATW Indoor, ATW Outdoor, ATW hold and Manual
Contrast Enhancement	Low, Medium, High
Sharpness	Sharpness enhancement level selectable
Alarm Output	VMD or Bilinx
Alarm Input (TTL)	Profile switching, +3.3 V nominal, +40 VDC max.

Alarm Output Relay	30 VAC or +40 VDC, Max 0.5 A continuous, 10 VA
Cable Compensation	Up to 1000 m (3000 ft) coax without external amplifiers (automatic set-up in combination with Bilinx coaxial communication)
Camera ID	17 character editable string, position selectable
Test Pattern Generator	Color bar, Raster, Impulse, Cross Impulse, Cross hatch,
Lens Types	Manual, DC-Iris DC-iris drive: max. 50 mA continuous
Lens Mount	CS (max lens protrusion 5 mm, 0.2 inch), C-mount compatible with adapter ring (optional)
Modes	6 preset programmable modes
Remote Control	Bilinx coaxial bi-directional communication
Video Motion Detection	4 areas, fully programmable
Privacy Masking	15 independent areas, fully programmable
E-Zoom	Up to 16x
Digital Image Stabilizer	On/Off
Controls	OSD with soft-key operation
OSD Language	English, French, German, Spanish, Portuguese, Simplified Chinese, Russian

Mechanical

Dimensions (H x W x L)	58 x 66 x 122 mm (2.28 x 2.6 x 4.8 inch) without lens
Weight (12 VDC/ 24 VAC)	500 g (1.10 lbs) without lens
Weight (230 VAC)	600 g (1.32 lbs) without lens
Color	RAL 9007 Metallic Titanium
Tripod Mount	Bottom (isolated) and top 1/4-inch 20 UNC

Environmental

Operating Temperature	-20°C to +55°C (-4°F to 131°F)
Storage Temperature	-40°C to +70°C (-40°F to +158°F)
Operating Humidity	20% to 93% RH
Storage Humidity	up to 98% RH

Ordering information

DINION AN 5000

960H analog indoor WDR box camera. True day/night; 720 TVL; 4-zone motion detect; 15-zone privacy mask; 12VDC/24VAC; 50 Hz; PAL
Order number **VBN-5085-C11**

DINION AN 5000

960H analog indoor WDR box camera. True day/night; 720 TVL; 4-zone motion detect; 15-zone privacy mask; 12VDC/24VAC; 60 Hz; NTSC
Order number **VBN-5085-C21**

DINION AN 5000

960H analog indoor WDR box camera. True day/night; 720 TVL; 4-zone motion detect; 15-zone privacy mask; 230VAC; 50 Hz; PAL
Order number **VBN-5085-C51**

Accessories

LVF-5000C-D2811 Varifocal Lens

960H varifocal IR-corrected lens. 1/3" sensor; CS-mount; 4-pin DC-iris; F1.4-360; 2.8 to 11 mm
Order number **LVF-5000C-D2811**

LVF-5000C-D0550 Varifocal Lens

960H varifocal IR-corrected lens. 1/3" sensor; CS-mount; 4-pin DC-iris; F1.6-360; 5 to 50 mm; high resolution; low distortion
Order number **LVF-5000C-D0550**

LTC 3664/31 Varifocal Lens

960H varifocal IR-corrected lens. 1/3" sensor; CS-mount; 4-pin DC-iris; F1.0-360; 3 to 8 mm
Order number **LTC 3664/31**

EX12LED-3BD-8M Infrared Illuminator

Mini IR 850 nm illuminator. LED array; 3D Diffuser; black; 17 m HFOV; 30° beam pattern
Order number **EX12LED-3BD-8M**

EX12LED-3BD-8W Infrared Illuminator

Mini IR 850 nm illuminator. LED array; 3D Diffuser; black; 16 m HFOV; 60° beam pattern
Order number **EX12LED-3BD-8W**

EX12LED-3BD-9M Infrared Illuminator

Mini IR 940 nm illuminator. LED array; 3D Diffuser; black; 17 m HFOV; 30° beam pattern
Order number **EX12LED-3BD-9M**

EX12LED-3BD-9W Infrared Illuminator

Mini IR 940 nm illuminator. LED array; 3D Diffuser; black; 16 m HFOV; 60° beam pattern
Order number **EX12LED-3BD-9W**

TC8235GIT Ground Loop Isolation Transformer

Order number **TC8235GIT**

UPA-2430-60 Power Supply

Power supply for camera. 120 VAC, 60 Hz; 24 VAC, 30 VA Out
Order number **UPA-2430-60**

UPA-2420-50 Power Supply

Power supply for cameras. 220 VAC, 50 Hz In; 24 VAC, 20 VA Out
Order number **UPA-2420-50**

UPA-2450-50 Power Supply, 220 V, 50 Hz

Indoor power supply for camera. 220 VAC, 50 Hz In; 24 VAC, 50 VA Out
Order number **UPA-2450-50**

UPA-2450-60 Power Supply, 120 V, 60 Hz

Indoor power supply for camera. 120 VAC, 60 Hz In; 24 VAC, 50 VA Out
Order number **UPA-2450-60**

S1374 Adapter

Adapter to convert C mount lens to CS mount camera
Order number **S1374**

Software Options

VP-CFGSFT Configuration Software

Configuration software for cameras using Bilinx. VP-USB adaptor
Order number **VP-CFGSFT**

Represented by:

Americas:

Bosch Security Systems, Inc.
130 Perinton Parkway
Fairport, New York, 14450, USA
Phone: +1 800 289 0096
Fax: +1 585 223 9180
security.sales@us.bosch.com
www.boschsecurity.us

Europe, Middle East, Africa:

Bosch Security Systems B.V.
P.O. Box 80002
5617 BA Eindhoven, The Netherlands
Phone: + 31 40 2577 284
Fax: +31 40 2577 330
emea.securitysystems@bosch.com
www.boschsecurity.com

Asia-Pacific:

Robert Bosch (SEA) Pte Ltd, Security Systems
11 Bishan Street 21
Singapore 573943
Phone: +65 6571 2808
Fax: +65 6571 2699
apr.securitysystems@bosch.com
www.boschsecurity.asia

China:

Bosch (Shanghai) Security Systems Ltd.
203 Building, No. 333 Fuquan Road
North IBP
Changning District, Shanghai
200335 China
Phone +86 21 22181111
Fax: +86 21 22182398
www.boschsecurity.com.cn

America Latina:

Robert Bosch Ltda Security Systems Division
Via Anhanguera, Km 98
CEP 13065-900
Campinas, Sao Paulo, Brazil
Phone: +55 19 2103 2860
Fax: +55 19 2103 2862
latam.boschsecurity@bosch.com
www.boschsecurity.com