

1 Introduction **A10U49 - UHF READER U4Go**

General description

A10U49 is a high performance UHF RFID integrated reader.

It supports fast tag read/write operation with high identification rate. It can widely applied in many RFID application systems such as logistics, access control, anti-counterfeit and industrial production process control system.



Working principle

The reader A10U49 generates continuously a RF signal in the band 902 - 928 MHz.

When a passive tag (card, sticker or car plate type), carried by an user or fixed on a vehicle enters in the RF field, generated by the reader, a small perturbation occurs: the tag replies with an encrypted signal, that includes its s/n and more information. These are then detected by the reader which transmits the signal to the decrypting I/F device, that makes them available in wiegand format or activate a relay.

The wiegand signal can be read by an Access Control System that gives the final authorization to the user.

The reader comes with the corresponding I/F device which has a RF receiver built-in, operating at 433,92 MHz, with a memory for 100 remote controls, type Erone 128.

The remote control can be used as an alternative means of identification from longer range, with the very high security level given by the 128 bit rolling code, encrypted AES128

2 U4Go Range

Part-name	Part-Number	Description
A10U48	F0103000125	READER UHF LONG RANGE U4GO 865 MHz
A10U49	F0103000126	READER UHF LONG RANGE U4GO 902 MHz
A6U48	F0103000127	READER UHF 6M U4GO 865 MHz
A6U49	F0103000128	READER UHF 6M U4GO 902 MHz
ATU48	F0103000129	ADHESIVE TAG U4GO
CHU4GO	F0103000031	CARD HOLDER U4GO
CTU48	F0103000132	CARD TAG U4GO
PTU48	F0103000134	CAR PLATE TAG U4GO
RXU4GO128	F0103000137	I/F RECEIVER U4GO - 128

3 Technical specifications : Reader

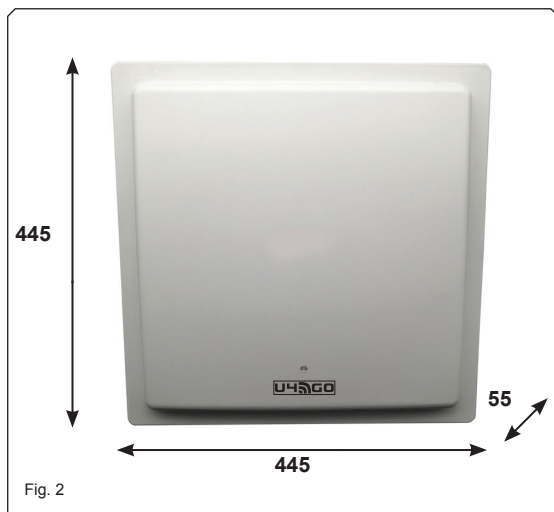
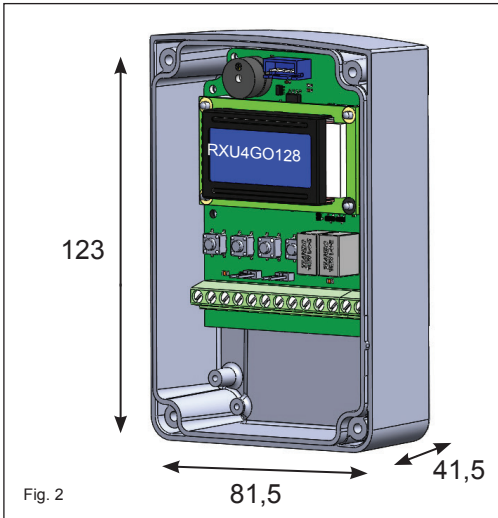

Fig. 2

Operating frequency range.....	902 - 928 MHz
Transmission type	FHSS
Detection range in open space.....	10 m (*)
Rated Power supply (Ta=25°C).....	9 Vdc (8V min,12V max)
Current consumption (average).....	350 mA
Max current consumption	650 mA
Operating temperature	-20°C ÷ +55°C
Storage temperature	-20°C ÷ +75°C
Weight	2,4 Kg.
Protocol tag supported	ISO18000-6B, ISO18000-6C
.....	EPC C1G2)
RF output power	up to 30 dBm (adjustable)
Output	RS-485
Dimensions.....	445 x 445 x 55 mm

(*) Effective distance depends on antenna, tag and environment

4 Technical specifications : I/F w/built-in radio receiver



- Operating frequency 433,92 MHz
- Demodulation GFSK
- Sensitivity (for good signal) -115 dBm
- Power supply: 12/24 Vac/dc
- Current consumption (@12 Vdc) from 25 to 50 mA (max)
- Encryption..... Rolling code w/encoding AES128
- Input RS-485
- Outputs Relay, Wiegand
- Wiegand protocols supported 26 - 30 - 44 bit
- Memory capacity 7560 tags
- 100 remote controls
- Relays..... 2 x 24 VA - max 48Vdc
- Relay operating mode pulse , step, delayed
- Delay from 1 sec. to 23 h : 59 min
- Retransmission period over wiegand bus... from 100 mS to 2 Sec.
- Relay pulse 300 mS
- Operating temperature: -10 ÷ +60°C
- Enclosure IP protection: IP55
- Dimensions: 120 x 80 x 40 mm
- Weight 65 gr.

5 Transmitters Erone 128

Part-name	Part-Number	Description
S3TR128E2	F1002000089	TRANSMITTER ERONE 128 2 CH
S3TR128E4	F1002000090	TRANSMITTER ERONE 128 4 CH



6 Mounting the reader

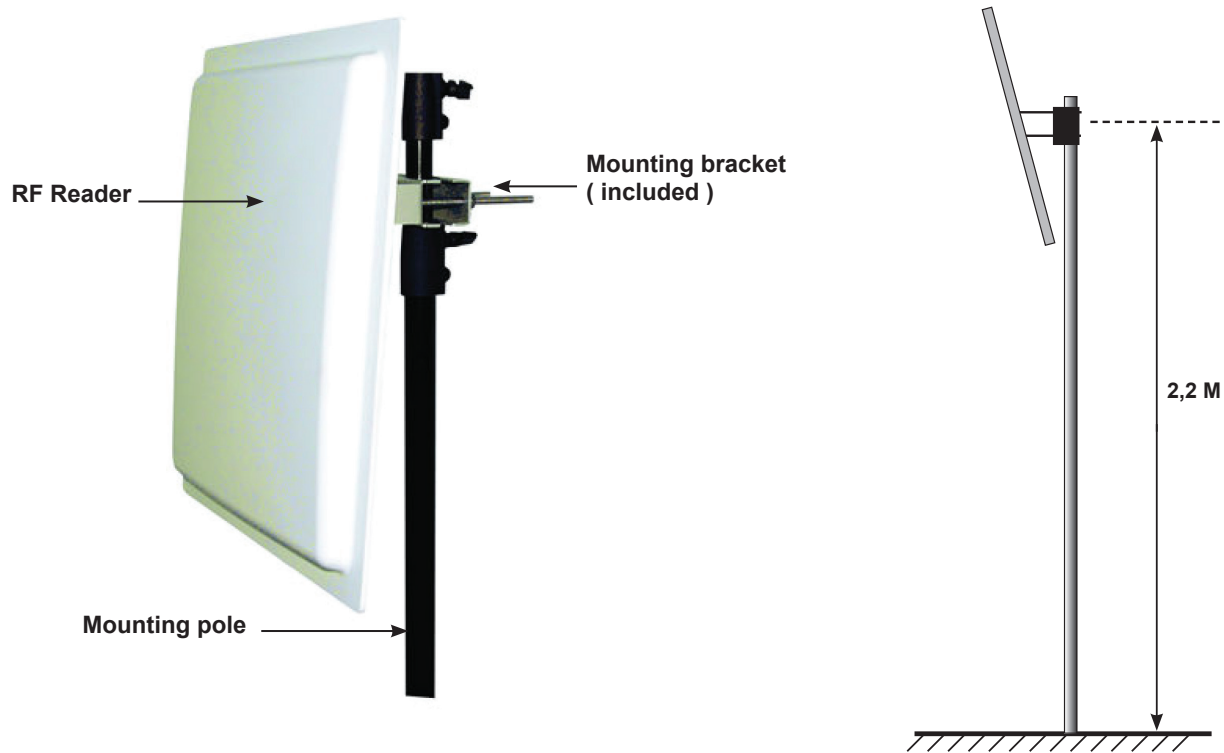

7 Mounting the I/F receiver

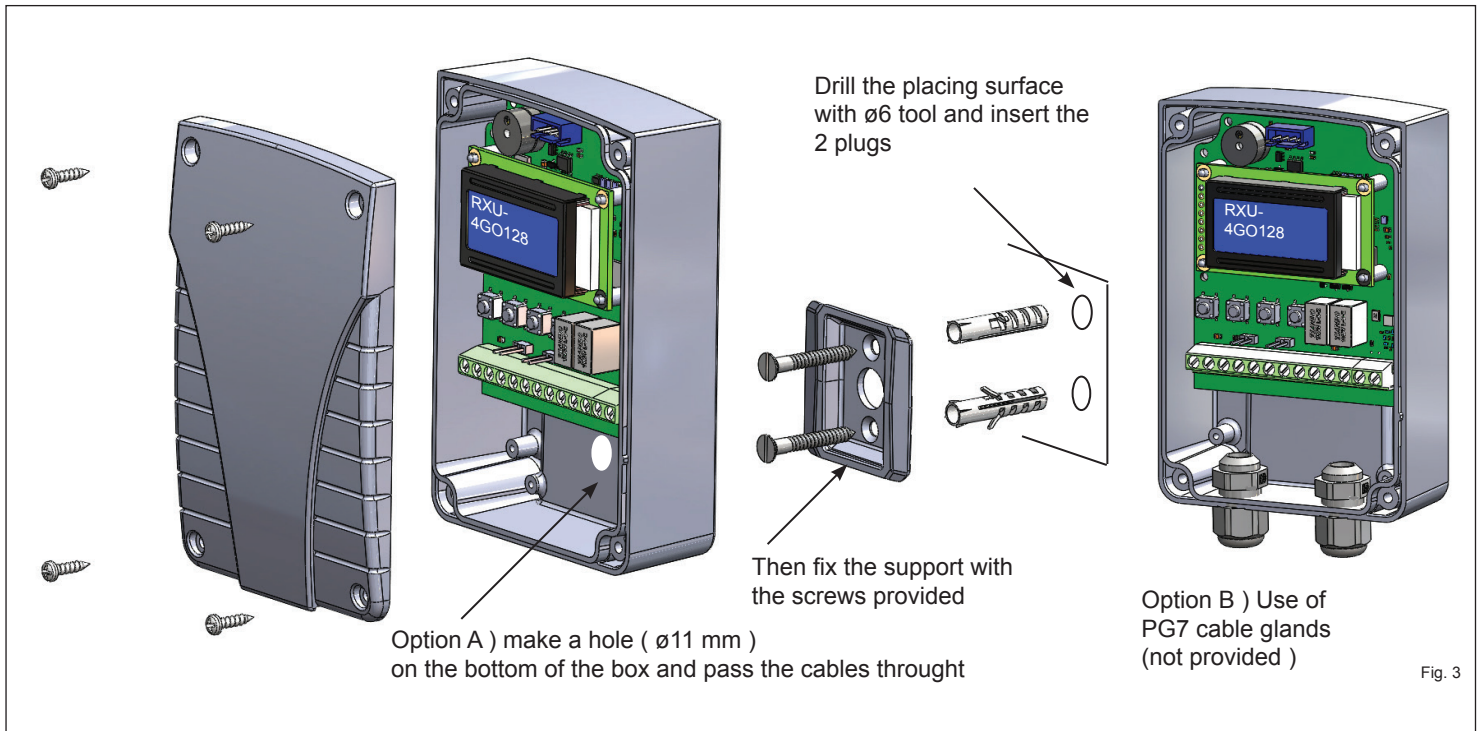

8 Connections

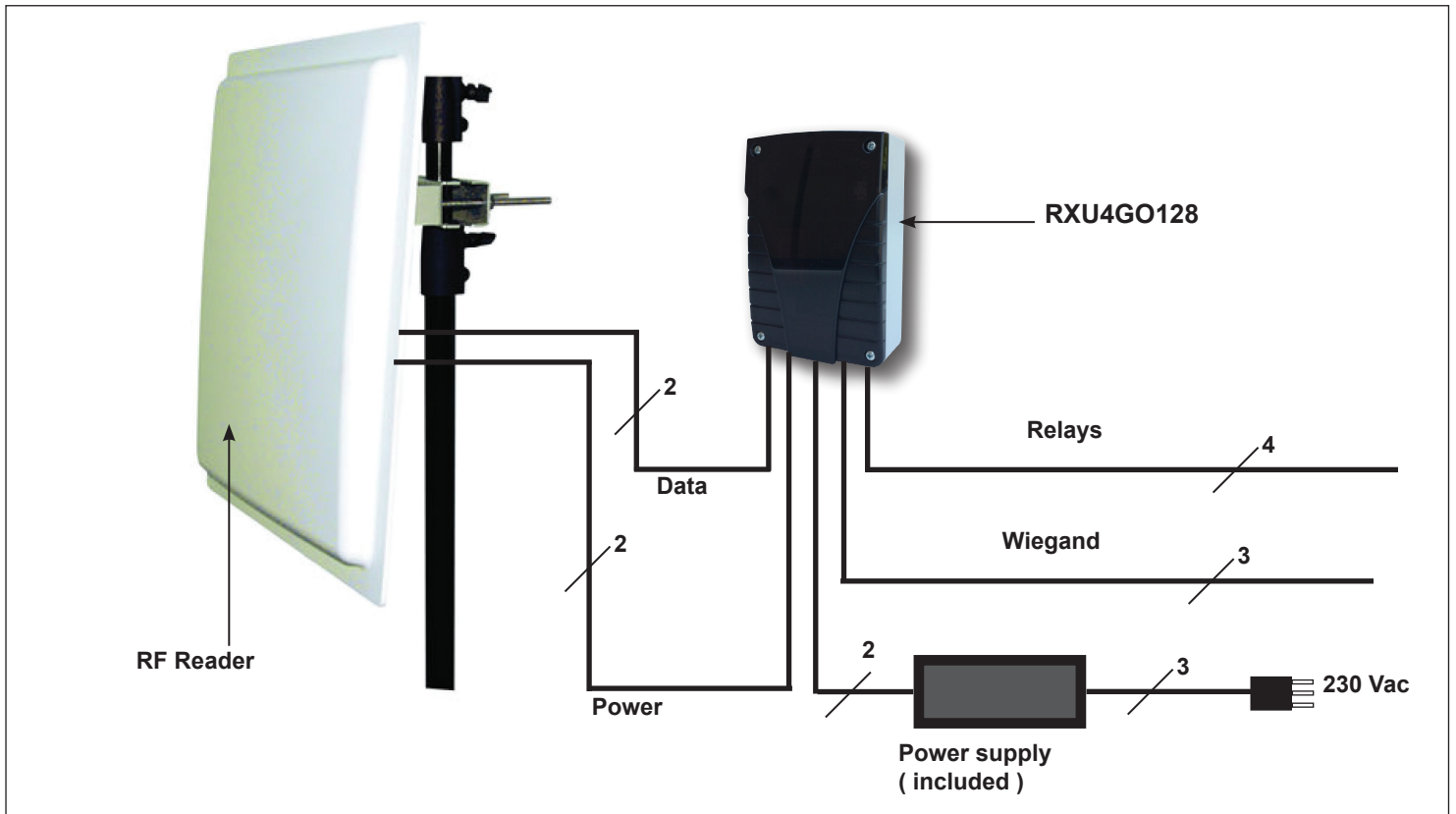

9 Wirings

Fig. 4

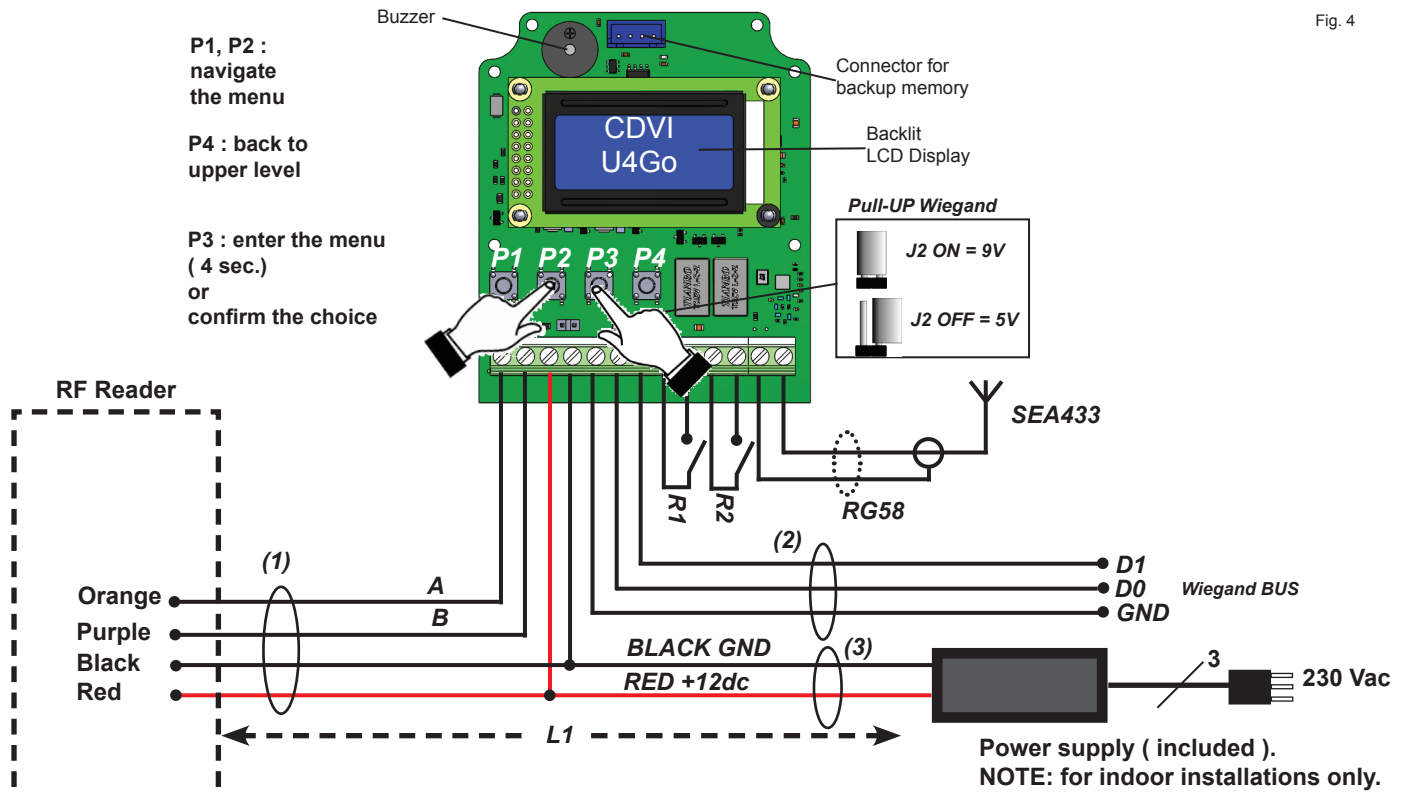

Example 1: TX reception

5	5	6	7	1	4	3	5
R 1	a	b	c	d	R 2		

TX Serial number

Button activated a, b, c or d

Relay activated

Example 2 : Status of the relays

R 1							
P	U	L	S	E			

Relay 1 : Pulse

R 1							
S	T	E	P				

Relay 1 : Step

R 2							
0	0	:	0	1	:	0	5

Relay 2 : Timed

R 2							
D	I	S	A	B	L	E	D

Relay 2 : Disabled

Delay setting

h	h	m	m	s	s		
0	0	:	0	0	:	0	1

The factory value for the timing is 1 sec. Use P1 to scroll the digits and P2 to confirm

Ref	Description	Wire type	Optional extension size	Maximum length
(1)	Cable from reader (0,7m)	2 conductors (RS485 bus)	24AWG (0,51 mm ²)	1220 m
		2 conductors (Power supply)	18AWG (1,02 mm ²)	L1 = 32 m MAX
(2)	Wiegand BUS	3 conductors Belden 9553	22AWG (0,64 mm ²) to 18AWG (1,02 mm ²)	150 m
(3)	Power supply	2 conductors	18AWG (1,02 mm ²)	L1 = 32 m MAX

10 Compatible UHF Tags

P/N	Description	Image	Suitable way
ATU48	ADHESIVE TAG U4GO		Stick on the surface of the glass
CTU48	CARD TAG U4GO		1) fixed with card holder 2) handheld by user
PTU48	Plate TAG U4GO		fixed on the surface of the metal

11 Side installation

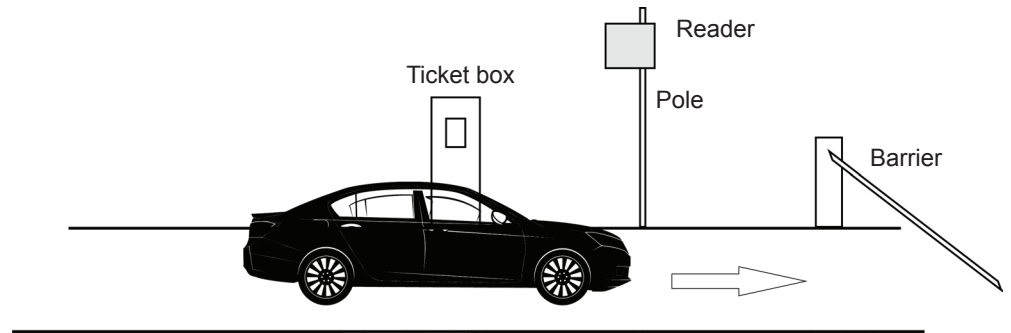
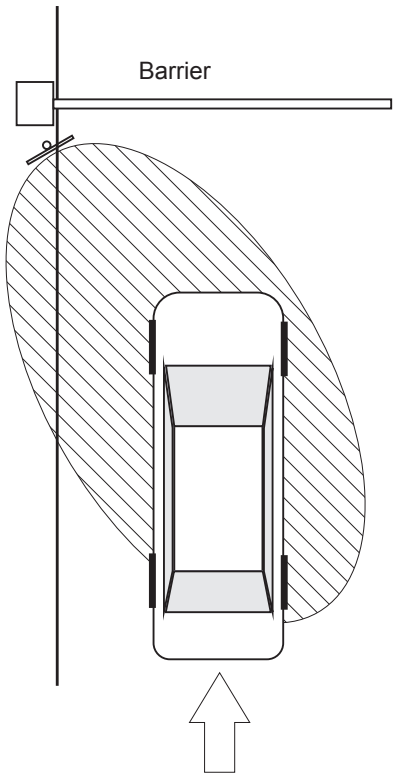

12 Over-head installation

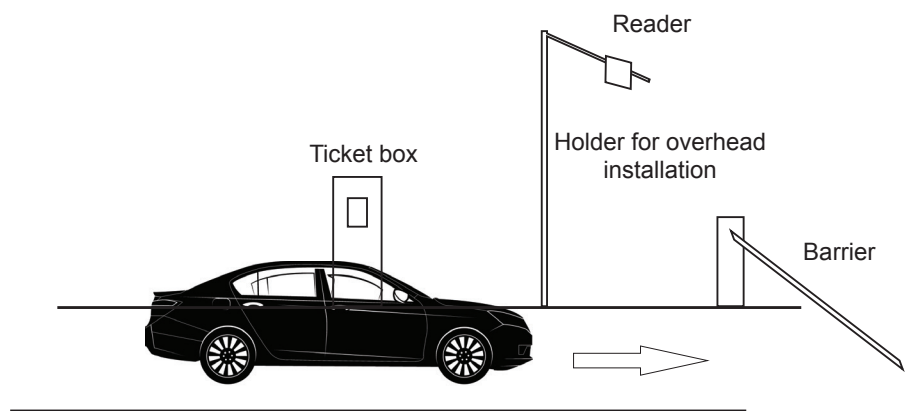
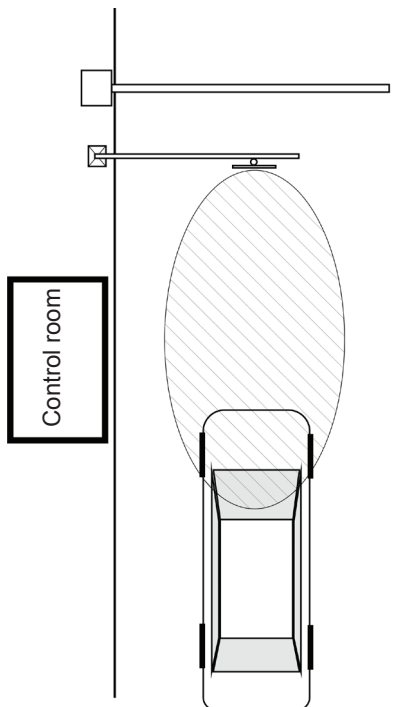

13 Getting started

When the antenna installation is complete, it is necessary to determine whether the interface device must activate the relays or simply sends in wiegand the serial numbers of tags.

Relay output: the serial numbers of the tags must be stored (see. Add Card). the memory can hold up to 7560 cards;

Wiegand output: if the interface device is connected to an access control panel, through the Wiegand bus, the pairing of the cards is not necessary and therefore there is *no memory limit*.

However, if the SELECTIVE OPERATION MODE is set, the memorization of a single tag will effect the wiegand communication, on which will pass the s/n of the only tags memorized.

Furthermore, if the installation requires the use of Erone 128 remote controls, which will be decoded by the built-in receiver, the remote controls must be memorized: the memory contains 100 transmitters. Erone - S3TR128E2, S3TR128E4

14 Programming / Navigation menu

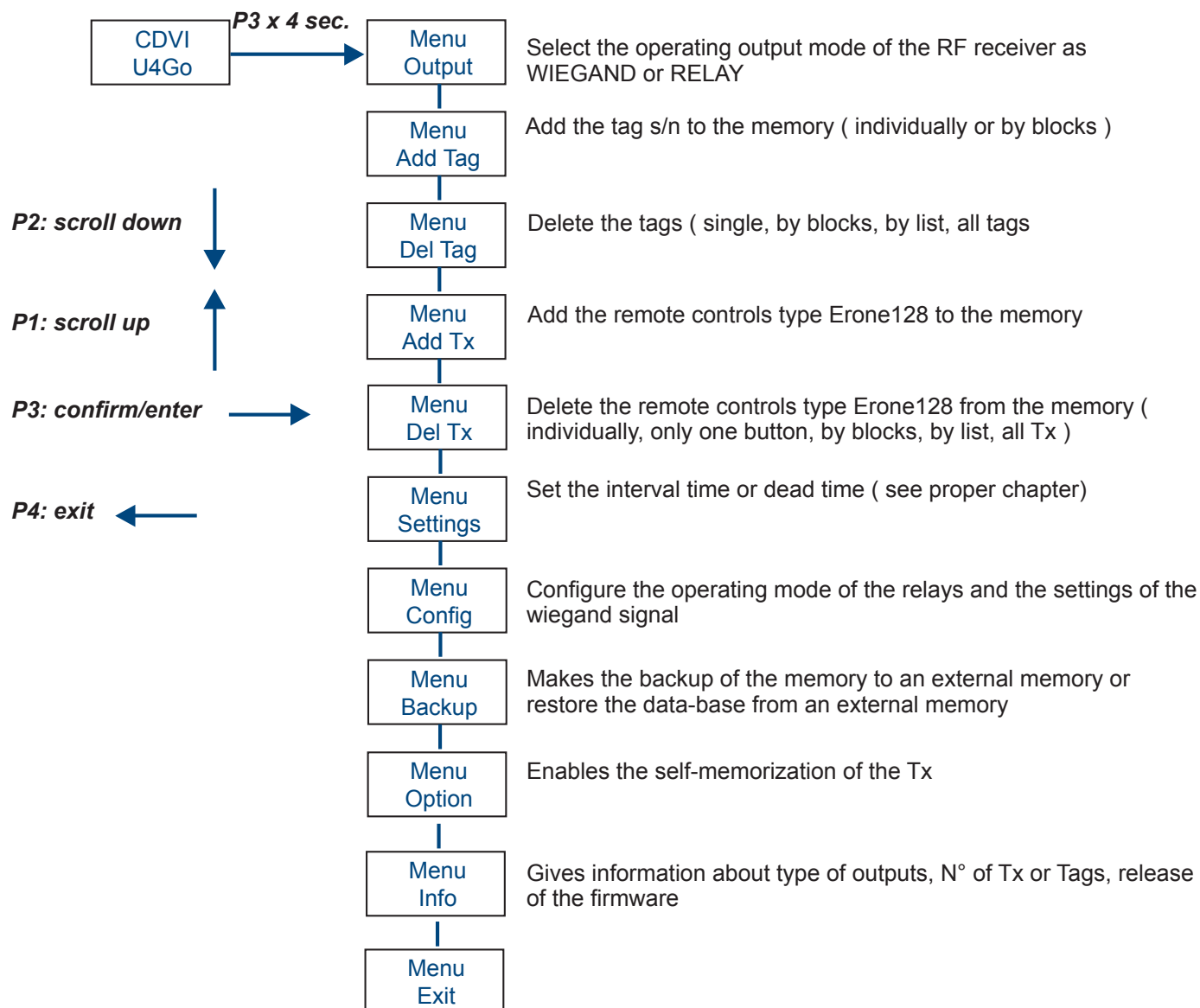

15 Add Tag [Single]

For adding a tag (card, plate, sticker) enter the option “Add Tag” of the main menu and “Add Tag again”.

m	e	n	u		
A	d	d	T	a	g



→

A	d	d	T	a	g

↓

W	a	i	t	T	a	g
0	0	0	0	0	0	0

↙ ↘

Show the Tag to the reader  

Type the S/N of the tag : enter the number using P1 or P2, shift left with P4

16 Add Tag [Block]

For adding a block of tags (card, plate, sticker) enter the option “Add Tag” of the main menu and “Add Tag Block”.

m	e	n	u		
A	d	d	T	a	g

↓

A	d	d	T	a	g
B	l	o	c	k	

→

H	o	w	m	a	n	y
T	a	g	?	0	0	0

Type the number of tag to memorize

↓



1	0	0	T	a	g	?
N	o			Y	e	s

Confirm (P1 for shift and P3 to confirm)

↓

W	a	i	t	T	a	g
0	0	0	0	0	0	0

↙ ↘

Show the Tag to the reader  

Type the S/N of the first tag of the block tag : enter the number using P1 or P2, shift left with P4

17 Delete Tag [Single]

For deleting a tag (card, car-plate, sticker) enter the option “Add Tag” of the main menu and “Delete Tag”.

m	e	n	u		
D	e	l	T	a	g



→

D	e	l	e	t	e
T	a	g			

↓

W	a	i	t	T	a	g
0	0	0	0	0	0	0

↙ ↘

Show the Tag to the reader  

Type the S/N of the tag : enter the number using P1 or P2, shift left with P4

↓

C	o	n	f	i	r	m	?
N	o			Y	e	s	

Confirm (P1 for shift and P3 to confirm)

18 Delete Tag [Multiple]

For deleting many tags you can do it by block, selecting them from a list, or delete the full memory.

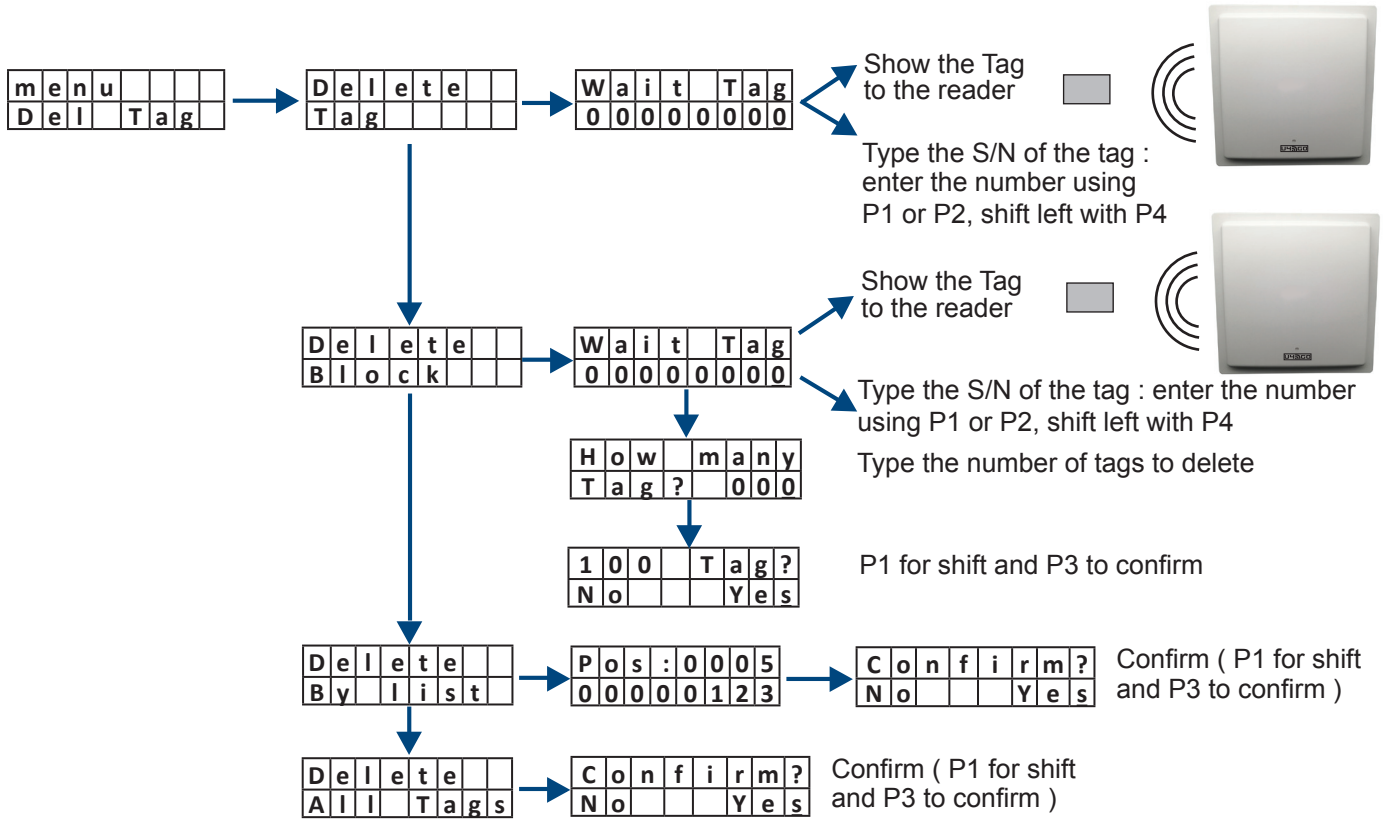

19 Add Tx

ATTENTION: The memorization of a TX, even just one, sets the SELECTIVE OPERATING MODE. That means that from that time on, the interface device filters and sends on wiegand the serial numbers the only TX memorized (100 TX)

Add RF transmitters to the memory (up to 100)

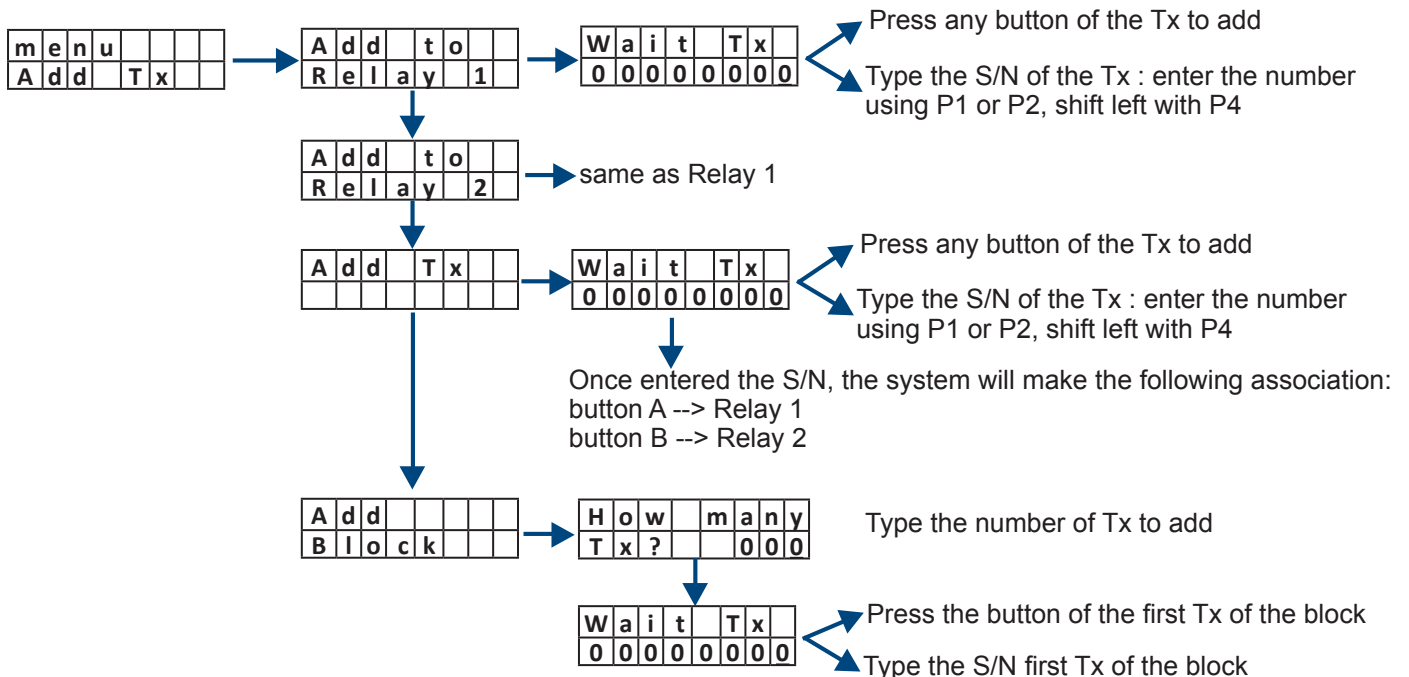

20 Del Tx

Delete RF transmitters from the memory (single or multiple

m	e	n	u				
D	e	l	T	x			

D	e	l	e	t	e		
T	x						

W	a	i	t	T	x		
0	0	0	0	0	0	0	0

Press any button of the Tx to delete
Type the S/N of the Tx : enter the number using P1 or P2, shift left with P4

Allows to specify which button activate the relay 1 or the relay 2

D	e	l	e	t	e		
B	u	t	t	o	n		

W	a	i	t	T	x		
0	0	0	0	0	0	0	0

Press any button of the Tx to delete
Type the S/N of the Tx : enter the number using P1 or P2, shift left with P4

R	e	l	a	y	1		
-	B	-	D				

Press P1 to add a Button and P2 to delete it, confirm with P3, shift back with P4

R	e	l	a	y	2		
A	-	C	-				

D	e	l	e	t	e		
B	l	o	c	k			

W	a	i	t	T	x		
0	0	0	0	0	0	0	0

Press any button of the first Tx of the block to delete
Type the S/N of the first Tx of the block to delete enter the number using P1 or P2, shift left with P4

D	e	l	e	t	e		
b	y	L	i	s	t		

P	o	s	:	0	0	0	5
0	0	0	0	0	1	2	3

Press P1 to scroll the list and P3 to confirm

C	o	n	f	i	r	m	?	
N	o					Y	e	s

D	e	l	e	t	e		
A	l	l	T	x			

C	o	n	f	i	r	m	?	
N	o					Y	e	s

21 Settings

m	e	n	u				
S	e	t	t	i	n	g	s

S	e	t	t	i	n	g	s
I	n	t	e	r	v	a	l

Sets the interval time between 2 next trains of bits carrying the S/N of the tag detected by the reader, as long as the tag stands in the field generated by the UHF reader. Values available : [0, 5, 10, 20, 30 Sec.]

S	e	t	t	i	n	g	s
D	e	a	d	T	i	m	e

Set the "deadtime" that is the time in which a tag, once carried out, must remain outside the detection field to be detected again. Available values [0, 1, 2, 3, 4, 5, 6, 7, 8, 9 Sec.]

S	e	t	t	i	n	g	s
A	d	d	r	e	s	s	

Sets the address of the reader : [0 - 9]. Factory value = 1
A different address of the reader can be used when 2 readers with the corresponding I/F are connected on the same wiegand BUS.

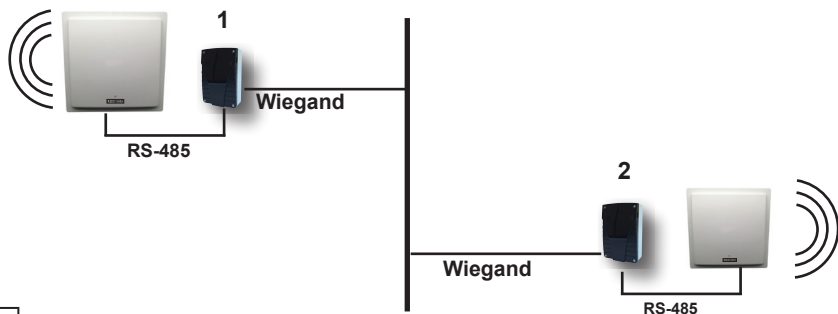

D	e	l	e	t	e		
S	e	t	t	i	n	g	s

Sets the receiver to the factory defaults.

22 Config

If the output is "Wiegand" set the wiegand protocol (26, 30 or 44 bit) and a filter on the Tx buttons
 If the output is "Relay" set the operating mode of the 2 relays as Pulse, Step, Timed or Disabled)

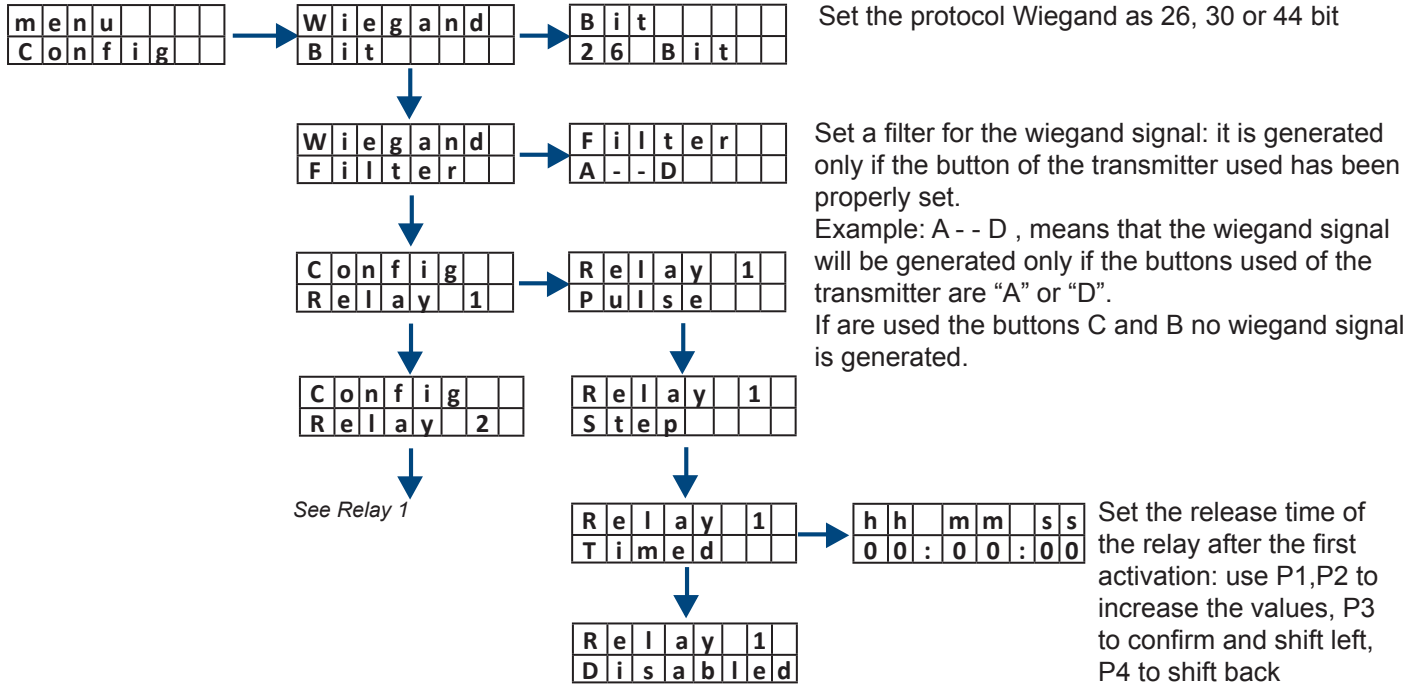

23 Backup

Allows to save the full internal data-base into an external memory or restore the data-base from an external memory

1) Plug-in the memory into the proper connector

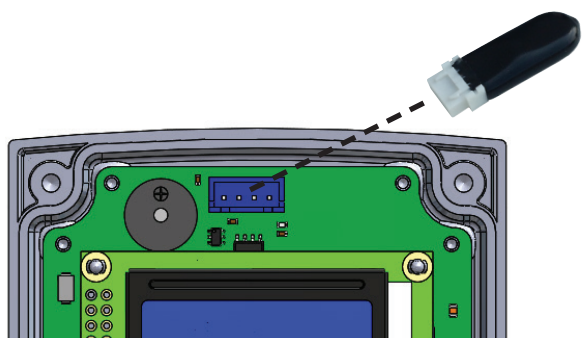

Red Rubber Memory = 512 Kbit

2) Enter the backup menu and select the option desired.

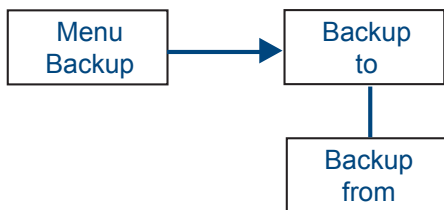

ATTENTION: the restore from an external memory will cause the overwriting of the all the data of the internal memory.

24 Option

The menu Option allows to enable (ON) or disable (OFF) the “Autoinstalling feature” : adding a new transmitter without accessing to the receiver. You need to use a transmitter already memorized for authorizing the autoinstalling function on a new unit. NOTE : at least one transmitter must be memorized in the receiver.

Take 2 transmitters (“old” and “new”) and hold next each other. (1)

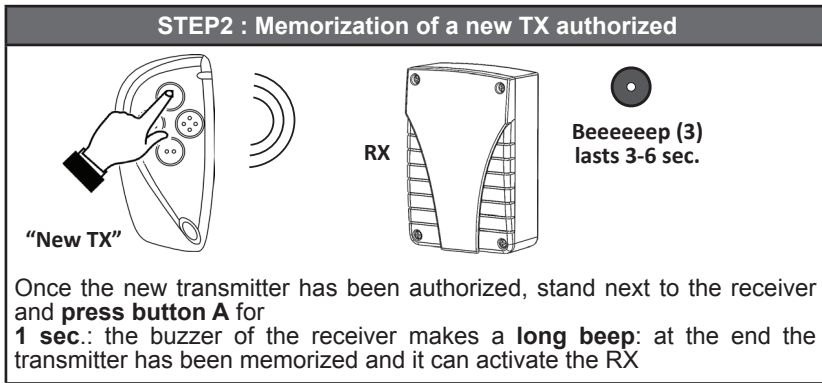
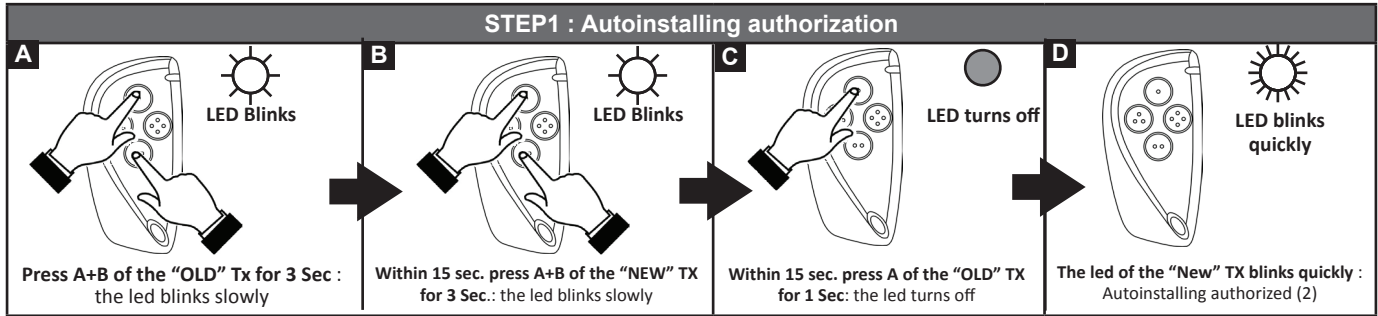

NOTES :

- (1): The “old” transmitter must be already memorized in the receiver
- (2): The autoinstalling feature, if enabled on the receiver (Option=ON), is limited to 15 attempts. If you press any button of the new transmitter out of the reception range of the receiver more that 15 times, the autoinstalling property stops and the procedure must be repeated.

(3): The beep of the receiver confirms the memorization: it will take 3-6 sec. to happen according to the number of transmitters stored.

25 Wiegand Output

The I/F - receiver converts in wiegand format both the S/N of the tags UHF and the S/N of the radio transmitters Erone 128 bit. The architecture of the wiegand signal is different according to the number of bits set (26, 30 or 44 bit).

25.1 Wiegand UHF

Wiegand 26	Bit 1	Bit 2 - 5	Bit 6 - 25	Bit 26
	Even Parity (1 bit)	[4 bit Address] (*)	[20 bit S/N]	Odd Parity (1 bit)

Wiegand 30	Bit 1	Bit 2 - 5	Bit 6 - 29	Bit 30
	Even Parity (1 bit)	[4 bit Address]	[24 bit S/N]	Odd Parity (1 bit)

Wiegand 44	Bit 1-4	Bit 5 - 8	Bit 9 - 40	Bit 41 - 44
	0000 (fixed)	[4 bit Address]	[32 bit S/N]	LRC (**)

(*) Is the address of the receiver set in the Settings submenu (see par. 21)

(**) Longitudinal Redundancy Check

25.2 Wiegand S/N of the radio transmitters

Wiegand 26	Bit 1	Bit 2 - 5	Bit 10 - 25	Bit 26
	Even Parity (1 bit)	[4 bit Button] (*)	[20 bit S/N]	Odd Parity (1 bit)
Wiegand 30	Bit 1	Bit 2 - 5	Bit 6 - 29	Bit 30
	Even Parity (1 bit)	[4 bit Button] (*)	[24 bit S/N]	Odd Parity (1 bit)
Wiegand 44	Bit 1-4	Bit 5 - 8	Bit 9 - 40	Bit 41 - 44
	0000 (fixed)	[4 bit Button] (*)	[32 bit S/N]	LRC (**)

(*) Code of the 4 buttons of a transmitter expressed in hex format, according to the table below

Button	Code
A	1010
B	1011
C	1100
D	1101

(**) Longitudinal Redundancy Check

26 Info

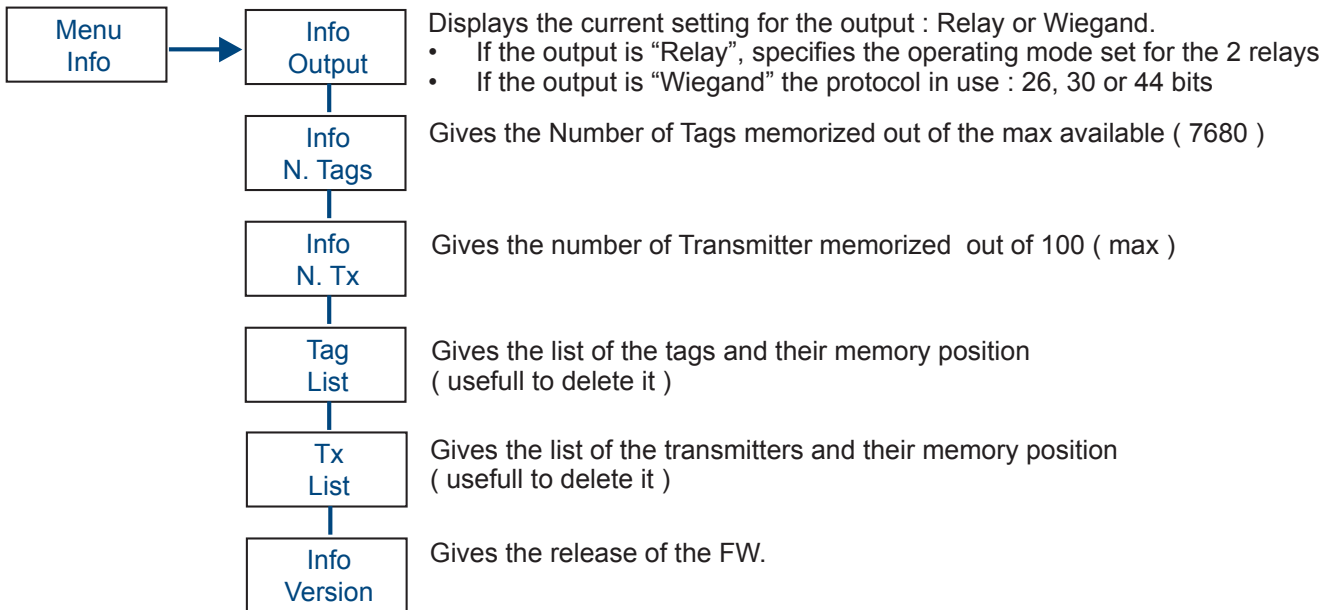

27 Installation of the tags

For vehicles without metalized windshield, you can choose one of the six places showed on the figure below to install (A - F).

For vehicles with pre-configured metalized windshield, it should have a reserved area that is not metalized for RFID tags according to the European Standard, so choose the position B.

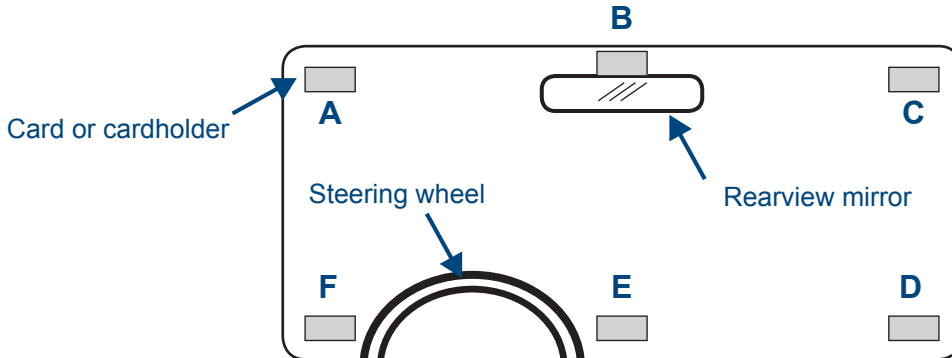

For optimum performance, choose A or F if the reader is in the left position of the windshield, or the position C or D if the reader is on the right position of the windshield.

Choose position B or E if the antenna is in the overhead of the traffic line.

REMARK : when there is a metalized windshield, the read range of the reader will be affected. Please test the performance before installation !



28 Parking garage application

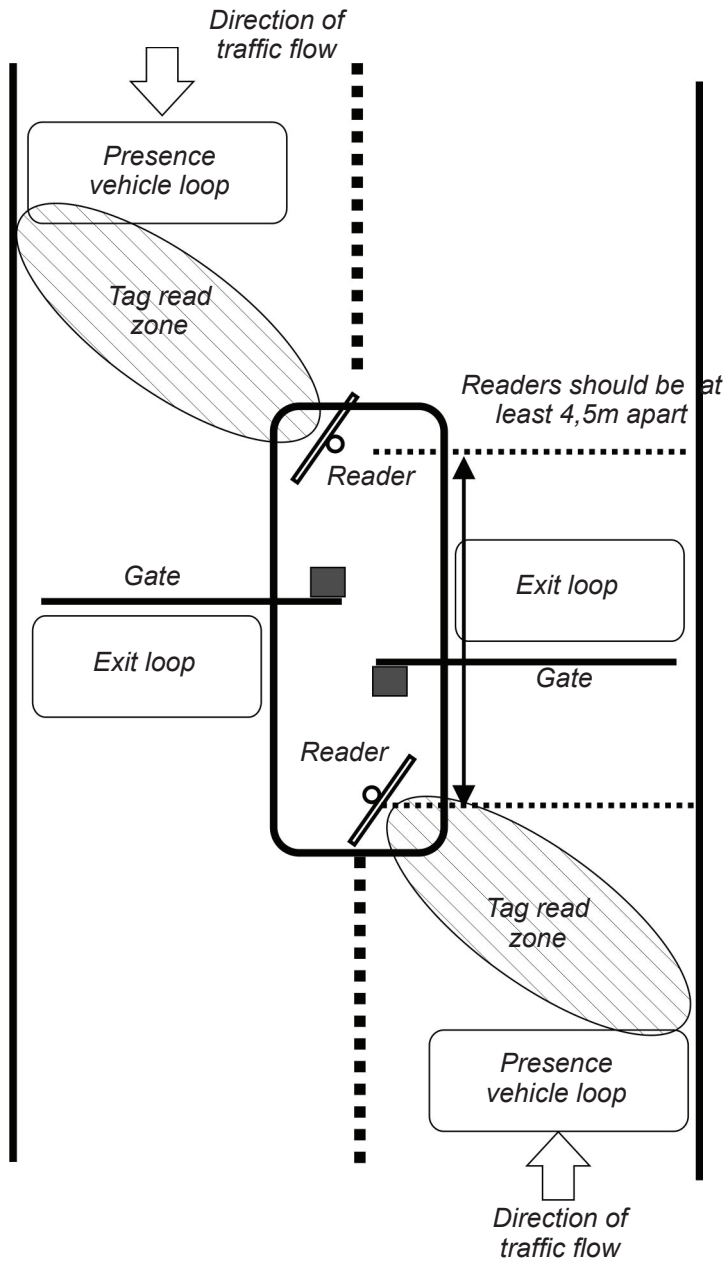

29 Holding the card by hand

The best position of the reader can be searched, in the first step holding the card by hand.

Attention: the card is very sensitive to the human hand.

The performance of detection can drastically change according to the way of holding the cards.

Look at the following images to understand the best holding way of the card



Hold the card with the outstretched arm, away from the body.

If the card is hold near the body the performances can decrease a lot.

A card held in the wallet cannot be detected.

A card in touch with the clothes cannot be read.

30 Installation of the sticker ATU48

The sticker position should be similar to the card, as described above.

Best use on the surface of a window or headlights.

IMPORTANT: the sticker, once fixed, cannot be rip off and reused.

Please test the performances before installation

31 Installation of the Licence plate PTU48

Use only for licence plate. Use the screws to fix the tag on the bottom of the licence plate

Please test the performances before installation

Hereby, CDVI Wireless Spa, declares that the radio equipment type A10U49 complies with the Standard 47 CFR FCC Part 15, subpart B. The full text of the Declaration of conformity is available at the following internet address: www.erone.com.

GUARANTEE

The warranty period for this product is 24 months, beginning from the manufacturer date. During this period, if the product does not work correctly, due to a defective component, the product will be repaired or substituted at our discretion. The guarantee does not cover the plastic container integrity. After-sale service is supplied at the factory.



IS-A10U49EN, Rev.1 on 10/7/2019