

Superterm Accelerator[™]

Plug-In Processor / Memory / Ethernet
Expansion for the Continental Superterm
and Sensormatic Sensorpanel II[™]

Model C1CP18ACCBD

Installation and Service Manual

Continental **Access** 

A NAPCO SECURITY GROUP COMPANY

355 Bayview Avenue, Amityville, NY 11701

Telephone: 631-842-9400

Fax: 631-842-9135

www.cicaccess.com

Publicly traded on NASDAQ Symbol: NSSC

FCC Warning

Changes or modifications to this unit not expressly approved by the party responsible for compliance could void the user's authority to operate the equipment.

NOTE

This equipment has been tested and found to comply with the limits for a Class A digital device, pursuant to Part 15 of the FCC Rules. These limits are designed to provide reasonable protection against harmful interference when the equipment is operated in a commercial environment. This equipment generates, uses, and can radiate radio frequency energy and, if not installed and used in accordance with the instruction manual, may cause harmful interference to radio communications. Operation of this equipment in a residential area is likely to cause harmful interference in which the user will be required to correct the interference at his own expense.

Shielded cables must be used with this unit to ensure compliance with the Class A FCC limits.

DISCLAIMER

Continental Access makes no representations or warranties with respect to the contents hereof and specifically disclaims any implied warranties of merchantability or fitness for any particular purpose. Further, Continental Access reserves the right to revise this publication and to make changes from time to time in the content hereof without obligation of Continental Access to notify any person of such revision or changes.

Information furnished by Continental Access is believed to be accurate and reliable. However, no responsibility is assumed by Continental Access for its use; nor for any infringements of other rights of third parties which may result from its use. No license is granted by implications or otherwise under any patent or patent rights of Continental Access.

Sensorpanel II is a registered Trademark of Sensormatic Electronics Corporation.

Copyright © 2007 by Continental Access. All rights reserved. No part of this publication may be reproduced, transmitted, transcribed, or stored in a retrieval system, without the prior written permission of Continental Access,
355 Bayview Avenue, Amityville, NY 11701. 631-842-9400

A NAPCO SECURITY GROUP COMPANY

THE INSTALLATION OF THIS PRODUCT SHOULD BE MADE BY QUALIFIED SERVICE PERSONNEL AND SHOULD CONFORM TO ALL LOCAL CODES.



	 <p>The lightning flash with arrowhead symbol, within an equilateral triangle, is intended to alert the user to the presence of uninsulated 'dangerous voltage' within the product's enclosure that may be of sufficient magnitude to constitute a risk of electric shock to persons.</p>  <p>The exclamation point within an equilateral triangle is intended to alert the user to the presence of important operating and maintenance (servicing) instructions in the literature accompanying the product.</p>
<p style="text-align: center;">WARNING</p> <p>This product generates, uses, and can radiate radio frequency energy and if not installed and used in accordance with the instruction manual, may cause interference to radio communications. It has been tested and found to comply with the limits for a Class A computing device pursuant to Part 15 of FCC Rules, which are designed to provide reasonable protection against such interference when operated in a commercial environment. Operation of this product in a residential area is likely to cause interference in which case the user at his own expense will be required to take whatever measures may be required to correct the interference.</p>	<p style="text-align: center;">UNPACKING AND INSPECTION</p> <p>Unpack carefully. This is an electronic product and should be handled as such. Compare the items received with the packing list with your order.</p> <p>BE SURE TO SAVE THE SHIPPING CARTONS AND INSERT PIECES. THEY ARE THE SAFEST MATERIAL IN WHICH TO MAKE FUTURE SHIPMENTS OF THE PRODUCT.</p>
<p style="text-align: center;">WARNING</p> <p>TO REDUCE THE RISK OF FIRE OR SHOCK HAZARD, DO NOT EXPOSE THIS PRODUCT TO RAIN OR MOISTURE.</p>	<p style="text-align: center;">MAINTENANCE</p> <p>User maintenance of this unit is limited to external cleaning and inspection.</p>

TABLE OF CONTENTS

DESCRIPTION	5
BEFORE INSTALLATION	5
ABOUT THIS MANUAL	5
<i>End-User Periodic Tests and Emergency Planning</i>	5
INSTALLATION	6
<i>Plugging in the Accelerator Board</i>	6
TROUBLESHOOTING	8
SUPERTERM ACCELERATOR COMPONENTS.....	9
ACCESSORIES & SPECIFICATIONS.....	10
<i>Model Numbers</i>	10
<i>Specifications</i>	10
<i>Maximum Recommended Cable Length</i>	10
WARRANTY	11

DESCRIPTION

The Superterm Accelerator™ adds wide-band Ethernet connectivity, greater memory capacity and higher speed processing to new and existing Sensorpanel II and Superterm installations. Existing installations may be upgraded with minimal rework at the facility. All field wiring for the Card Readers, Electrical Locks, Alarm and Accessory Relay circuits remain intact.

The main benefits of the Superterm Accelerator are greater cardholder capacity to support the needs of a growing facility and much faster database downloads to complete these larger downloads in less time.

The larger capacity makes the Accelerator-equipped Superterm the preferred platform for emerging large badge formats such as FIPS201, PIV and TWIC.

MIS costs associated with the use of Ethernet cables are minimized because the existing EIA/RS-422 Repeater Network Wiring may continue to be used to link panels together. Thus, one Ethernet cable may serve as many as 63 Access Control Panels that are equipped with the Superterm Accelerator.

Other communication configurations exist, including direct Ethernet connection to each panel, high-speed EIA/RS-422 connections (460.8 KBaud), and even a high-speed EIA/RS-232 (921.6 KBaud) connection. See Communications Options, publication # WI1617.

The Accelerator Board may be installed in the following equipment:

- Superterm All Models
- Turbo Superterm All Models
- Sensorpanel II™ All Models

Note: Sensorpanel II is a registered Trademark of Sensormatic Electronics Corporation.

CA3000 - Software Release 2.51 or later is required.

BEFORE INSTALLATION

Before installing the Accelerator PC board, be sure the existing control panel is working properly. Once an individual panel has been tested and found operating satisfactorily, it can then be safely upgraded by the installation of the Accelerator board.

Only qualified service personnel familiar with all local building codes should attempt this installation. Take appropriate safeguards to avoid unintentional operation by employees and maintenance personnel working about the premises.

The main control panel is categorized as PERMANENTLY CONNECTED EQUIPMENT with fixed wiring. This system must be installed within the protected premise in accordance with the National Electrical Code (NFPA70), local codes, and the authorities having jurisdiction.

A Ground Bond Strap is bolted between the Enclosure and the Door to reduce the risk of electric shock. If the Ground Bond Strap is unbolted from the Door to allow the Door to be removed, it is critical that the Ground Bond Strap be correctly attached before putting the Access Control Unit into service.

The warnings listed below are designed for the safety of the install/service technician and for the continued proper function of the unit.



ABOUT THIS MANUAL



This manual describes the installation of the Superterm Accelerator board.

End-User Periodic Tests and Emergency Planning

The Host Computer Software supervises the Access Control System, reporting failures at an individual panel within seconds of the occurrence. Nevertheless, failures can occur at the Door Sense and Bypass contact monitoring hardware, the individual Card Reader electronics and wiring, or the Electric Door Lock Hardware that will not be detected until the equipment is used. For this reason, please instruct staff at the installation to perform a "walk through" test at every controlled entrance and verify operation of all the monitored contacts at least once per week, especially at sites that are less frequently used. Assist the Security Staff at the installation to devise acceptable alternates to allow entrance and monitoring of access at controlled sites impacted by equipment failures, especially in high-traffic areas.

Provide staff members at the facility with contact information that will help assure the swift correction of equipment outages.

NOTES:	Notes are included with a procedure informing the installer about related material.
CAUTION 	Cautions indicate that a particular process requires special attention.
WARNING 	Warnings indicate that a particular process exposes the installer to live circuits or that making wrong connections can lead to equipment failure.
CAUTION 	Do not place accessory circuit cables in the same conduit sections containing power cables.

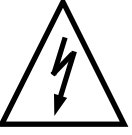
CAUTION 	Prevent the risk of a fire by replacing ALL fuses with the same type and rating. The main fuse protects the power supply circuit against excessive currents and short circuits. Failure of the power supply (other than a blown fuse) usually indicates a fault in a power supply component. There are no user-serviceable parts in the panel cabinet. Replace the power supply if it fails.
WARNING 	The lower part of the power supply has exposed terminals and components (see page 10). DO NOT probe the power supply and expose yourself to high voltage and a shock hazard.
WARNING 	The risk of a serious electrical shock exists if the wiring harness power connector is removed from the Super Two circuit board, but AC power remains live at the AC Input Terminal Block (see Figure 7, page 15).

INSTALL THE ACCELERATOR BOARD



Keep the black protective antistatic foam in place until the Accelerator PCB is installed. The anti-static foam protects the 40-pin header on the bottom of the Accelerator PC board.



Prior to opening the Accelerator PCB package or touching anything inside the control panel enclosure, discharge any static electricity from your body or clothing. Use a grounded wrist strap or touch an unpainted, grounded metal object such as the metal frame of the panel enclosure.

1. Inside the panel housing, remove power from the main PCB by pushing the POWER plug connector (located on the lower right of the PCB) downward until the connector is completely separated from the PCB. Do not disconnect the battery wires. See Fig. 1, below.

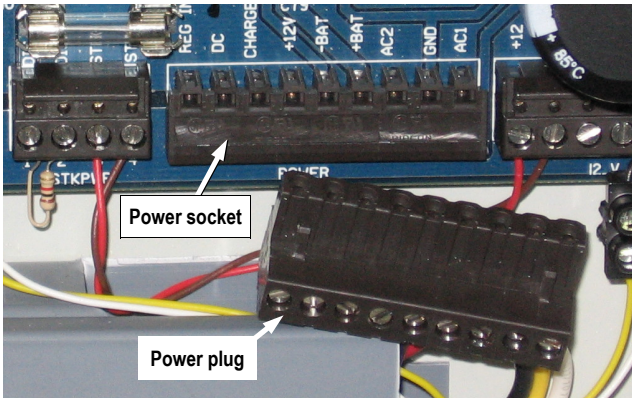

Fig. 1: Push POWER plug connector downward until removed.

2. Remove any Memory Expansion Boards located in U55 and/or U56 (circled in Fig. 2, below). **Note:** The EPROM (U39) and the on-board SRAM (U61) may be removed or left in place, as desired.

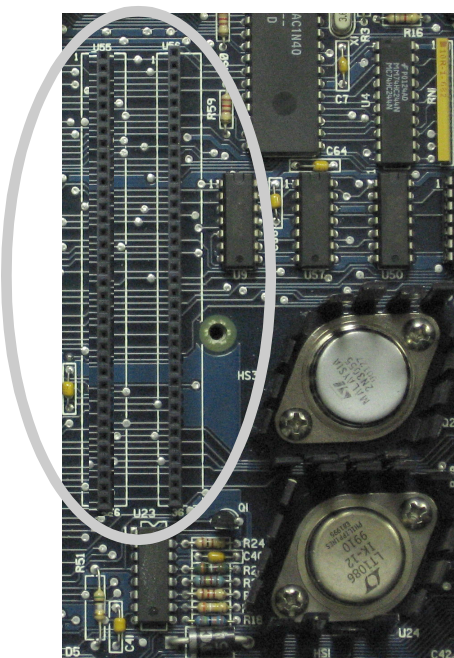

Fig. 2: Empty location "U56" (circled above).

3. **IMPORTANT:** To avoid damaging the Accelerator board pins, remember to remove U37, the 40-pin processor chip. Location U37 is the 40-pin receptacle into which the Accelerator PCB will be placed. See image in Fig. 3 for the location.

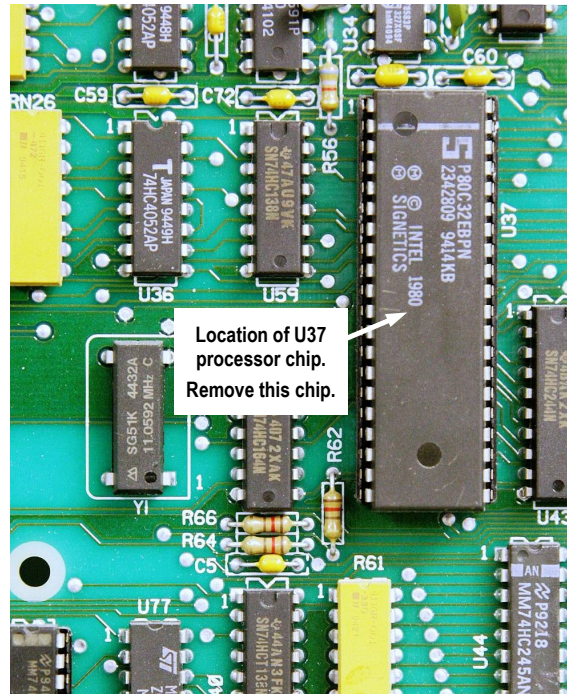

Fig. 3: Remove the processor chip located in "U37".

4. Carefully cut and remove the resistor labeled "R62". This resistor "R62" is located near the center of the motherboard, just left of "U37" as shown in Fig. 4, below.

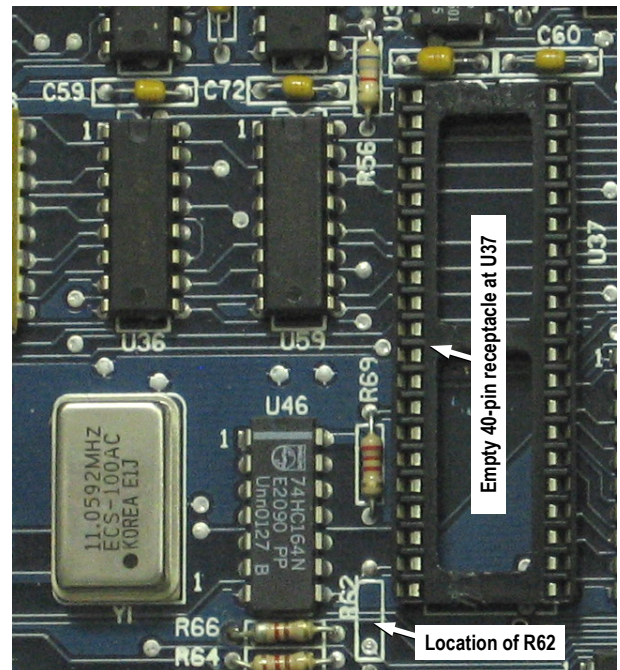

Fig. 4: Location of resistor "R62". This resistor MUST be removed.

- Remove any screws or fasteners from the 6-32 threads located near HS3 (heat sink #3). See Fig. 5 .

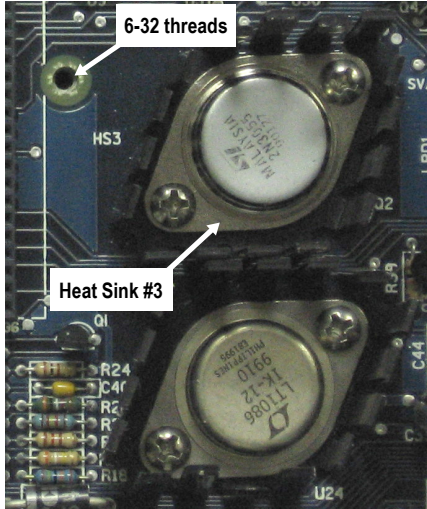

Fig. 5: Location of threads near HS3.

Into these 6-32 threads, install the 3/4" nylon male-to-male standoff with brass inserts (threads) provided. **Note:** "Finger tight" is sufficient. See Fig. 6.

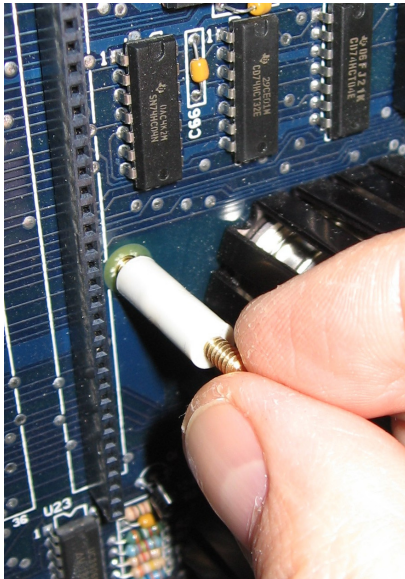

Fig. 6: Install the 3/4" male-to-male standoff.

- Find the two existing white nylon snap-lock standoffs on the upper-left of the PC board (see Fig. 7). Be sure they are straight (these standoffs may have bent over time).



Fig. 7: Photo of one of the two white nylon snap-lock standoffs located at the upper-left of the PC motherboard.

- Remove the protective black foam pad from the 40-pin header on the bottom of the Accelerator PC board. Be careful--pins are delicate and are easily bent.
- Align the board:** Hold the Accelerator PC board with its left side angled slightly closer to the motherboard (Fig. 8). Gently place the two left Accelerator PC board mounting holes over the two snap-lock standoffs (do not insert fully). Then place the lower-right Accelerator mounting hole over the brass insert of the male-to-male standoff (do not insert fully).

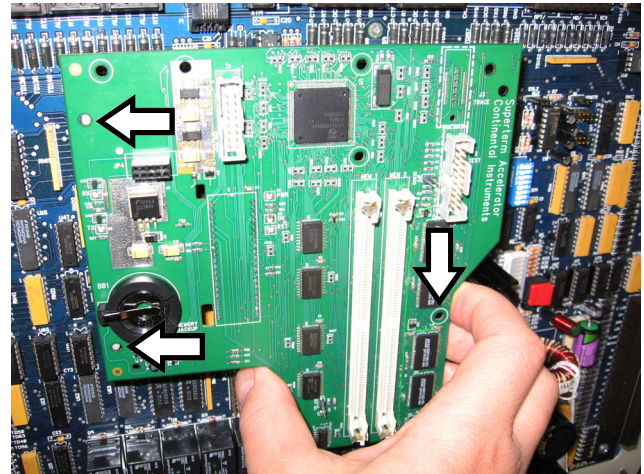

Fig. 8: Arrows indicate location of the two left Accelerator PC Board mounting holes. Place holes over the two snap-lock standoffs before placing over male-to-male standoff--do not insert yet.

Note: Two viewing holes (see Fig. 9 for locations) allow the use of a flashlight to check the pin alignment.

Insert the board: With all three mounting holes placed over all three standoffs, place fingers over the 40-pin header on the Accelerator PC board as shown in Fig. 9. Press evenly between the two 40-pin header rows with fingers of your right hand while simultaneously applying pressure over the two left mounting holes until the board snaps into place. Press more firmly over the 40-pin header to verify the header is fully seated in place.

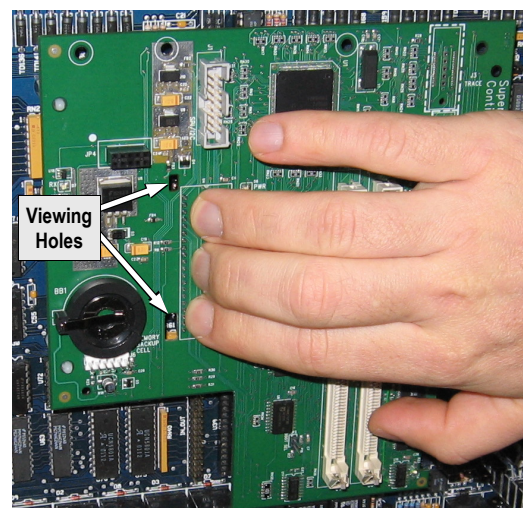

Fig. 9: Press evenly between the two 40-pin header rows with your right hand fingers while gently pressing over the two left mounting holes. The board snaps into place.

INSTALLATION

9. In the plastic parts bag, find the 3/8" white nylon 6-32 thumb nut. Carefully thread this nut into the brass threads of the male-to-male standoff (previously installed in step 5). **Note:** "Finger tight" is recommended. See Fig. 10.



Fig. 10: Thread the thumb nut into the brass threads of the male-to-male standoff "finger tight".

10. Re-connect power from the main Superterm PCB by pushing the POWER plug connector on the lower right of the PCB upward into the PCB. Verify that the OK lamp (LED) on the Accelerator board blinks on and off once per second. Also verify the heartbeat lamp on the motherboard (location T1) blinks in unison with the OK lamp on the Accelerator board.
10. Move the MEMORY BACKUP CELL jumper from the OUT position to the IN position (see Fig. 11). The jumper in the IN position provides memory data retention for about two weeks after AC Mains has failed and the Gel-cell backup power has been fully discharged.

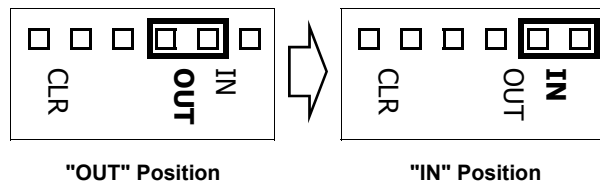

Fig. 11: Move the Memory Backup Cell jumper from the "OUT" position (shown above left) to the "IN" position (shown above right).

Note: Move the jumper to the OUT position if the board will be un-powered for more than a few hours.

Note: A drained Memory Backup Cell may be replaced with another Duracell DL2032 type battery cell.

Note: The lithium battery on the main PCB is still used to provide backup power to the Superterm Clock/Calendar chip.

TROUBLESHOOTING

If either the OK lamp (LED) on the Accelerator board or the heartbeat lamp on the motherboard (location T1) fails to blink in unison, perform the following:

1. Press and hold the red RESET button on the main board for 4 seconds, then release. Wait 10 seconds. If the two lamps are still not functioning correctly, proceed to the next step.
2. Remove power from the main motherboard PCB by pushing the POWER connector (located on the lower right of the PCB) downward until the connector is completely separated from the PCB. Wait 10 seconds and reconnect the POWER connector. If the lamps still do not function correctly, proceed to the next step.
3. Remove the Accelerator board as follows: Remove power from the main motherboard PCB, then move the MEMORY BACKUP CELL jumper from the IN position to the OUT position. Remove the male-to-male standoff thumb nut. Push in the tabs of the two white nylon snap-lock standoffs as shown in Fig. 12 and carefully remove the Accelerator board. Check for and straighten any bent pins and try re-installing the Accelerator board again.

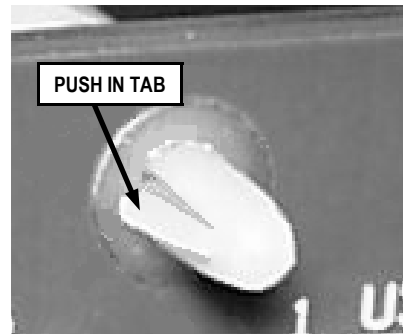

Fig. 12: Push in tab to detach "snap lock" type standoff.

Note: When the Accelerator board is not installed, replace the black protective antistatic foam to fully cover the 40-pin header of the Accelerator board.

4. If any CICP18MEM8MB memory modules are installed, remove power and remove the memory modules. Reconnect the POWER connector to verify normal operation of the OK and heartbeat lamps.

SUPERTERM ACCELERATOR COMPONENTS

Mounting Holes – For the optional Ethernet Interface or the EIA/RS-232 Interface.

Connector – For the optional Ethernet Interface or the EIA/RS-232 Interface.

Lithium Coin Cell and Holder – Replace drained cell with a Duracell DL2032.

Jumper Block – Place in OUT position when board is not in service. Place to IN position to maintain Database Memory during long-term power failures.

Expansion Memory Sockets – Each Module adds 8MB of battery-backed static RAM.

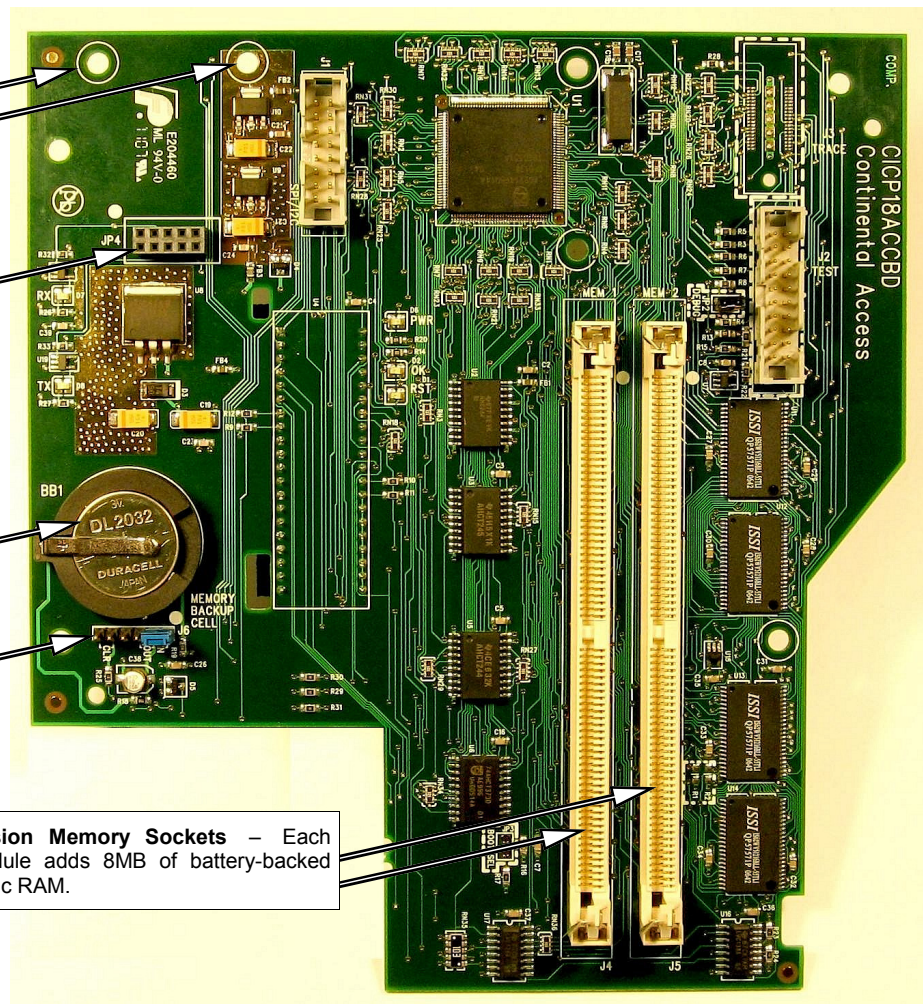

Rx – Receiving Data on Plug-in Ethernet Port or High Speed EIA/RS-232 Channel.

Tx – Transmitting Data on High Speed Port.

PWR – Receiving 5 Volt power from

OK – Flashes in unison with the "Heartbeat" Lamp on the Panel during normal operation.

RST – Blinks on during Panel Reset. A steady blink indicates *Watchdog Timer* activity.

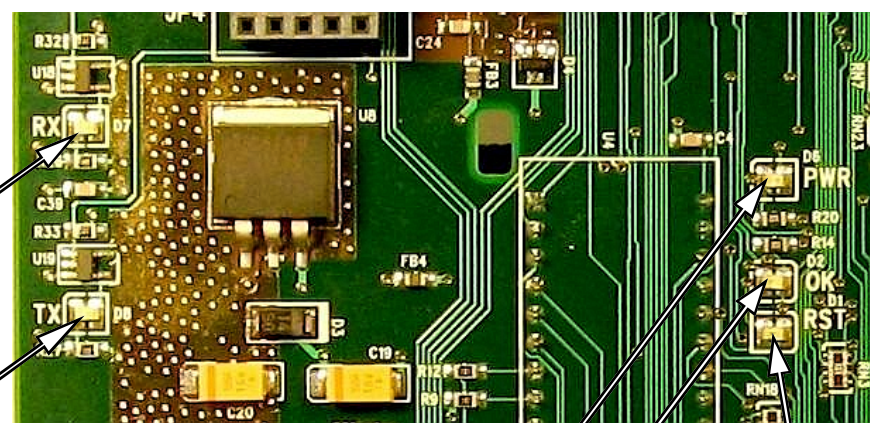

ACCESSORIES & SPECIFICATIONS

ACCESSORIES

Description	Model Number	Comments
Ethernet Module	CICP18ACCNETBD	Adds 10/100Base-T Ethernet to Accelerator
EIA/RS-232 Module	CICP18ACCEIABD	Adds high-speed EIA/RS-232 to Accelerator
8 MB Memory Module	CICP18MEM8MB	

Note: Only one Ethernet or EIA/RS-232 Plug-in Board may be added to an Acceleration Board. Two 8 MB Memory Modules may be added, to bring the total capacity to 20 MB.

The Superterm Plug-in Accelerator provides Processor/Memory/Network Enhancement for the following equipment:

Superterm	CICP1400UL CICP1400ULExp CICP1800 CICP1800Exp
Turbo Superterm	CICP1400TUL CICP1400TULExp CICP1800T CICP1800TExp
Sensorpanel II¹	

¹CA3000 Version 2.51 or later is required.

Note: The Accelerator will not operate with Sensormatic® AC500 Software.

SPECIFICATIONS

- 32-Bit ARM7TDMI Processor running at 58.94 MHz
- Program Code Memory held in 256KB FLASH Memory internal to the 32-bit processor
- Base Memory 32-Bit wide 4MB on board for Database; Approximately 120,000 Cardholder capacity
- Each plug-in 8MB Memory Expansion Module increases cardholder capacity by about 250,000 cards. With two modules, approximately 600,000 cardholder capacity is available.

Note: The number of Badge Digits, Activity Links, Access Groups, and Transaction Buffer size required will influence the total Cardholder Capacity.

Maximum Recommended Cable Length :

EIA/RS-232	
Baud Rate	Practical EIA/RS-232 Distance Limits
921.6KBaud	10 Feet
460.8KBaud	20 Feet
230.4KBaud	40 Feet
115.2KBaud	80 Feet

EIA/RS-422	
Baud Rate	Practical EIA/RS-422 Distance Limits (Between Panels)
460.8KBaud	1000 Feet
230.4KBaud	2000 Feet
115.2KBaud	4000 Feet

Ethernet	
Speed	Limits defined by IEEE802.3 for CAT5/6 Copper Cable (to Switch or Router)
10/100Base-T	100 Meters (305 Feet)

WARRANTY / TERMS & CONDITIONS

Standard Terms of Sale

Ordering

Orders for Continental products may be placed by calling Continental's order department or by issuing a purchase order specifying the quantity of Products, the desired delivery date, shipping method, and the location to which product should be shipped. If an order is placed by telephone, it must be confirmed in writing by fax or mail.

If the customer requests a guaranteed ship date or expedited shipping, Continental reserves the right to add to the price, with the customer's approval, expenses which increase the cost of production and delivery, i.e. freight charges, overtime expenses, etc. Continental reserves the right to change any price on this price list and all prices are subject to factory reconfirmation at the time of placing an order.

Sales Assistance

Continental will furnish to customers, reasonable quantities of product-related catalogs and other sales and promotional literature.

Continental will provide customer training, both technical and sales at Continentals facilities in New York. Contact the factory for costs and requirements.

Payment Terms

- Sales terms are Cash on Delivery (COD) unless prior credit arrangements are established.
- If credit arrangements are established with Continental, terms of sale are net 10 days.
- Interest charges shall accrue on all past due accounts at a rate of 1.5% per month (18% APR).
- Continental reserves the right to place a customer on a C.O.D. status in the event that customer's account becomes delinquent or Continental becomes unsure about customer's financial capabilities.
- Continental will charge a Service Fee of \$50.00 for any returned check.
- If customer believes an invoice to be in error, customer shall notify Continental of the error within thirty (30) days.
- Continental reserves a security interest in all products sold hereunder, together with all proceeds thereof to secure the performance of the customer's obligations hereunder.
- All orders unless otherwise requested are shipped F.O.B. Amityville, NY.

Cancelled Orders

Special or custom order items that cannot be cancelled with our suppliers are subject to a 100% cancellation charge.

No unauthorized, returned merchandise will be accepted for credit.

Orders returned or canceled are subject to a 25% restocking charge.

Return Material Authorizations

No products will be accepted for return to Continental without prior written authorization (RMA). Unauthorized returns will not be accepted from the carrier by the receiving department. The customer may request a return material authorization (RMA), whether for credit or repair of the product. Continental will either issue an RMA or provide the customer with a written explanation for not issuing the RMA. Except for warranty claims, no returns will be accepted more than 60 days after shipment from Continental. Orders that are accepted for return are subject to a 25% restocking charge. No product will be accepted for return which has been special ordered or custom in nature.

Limited Warranty

Return Material Authorization (RMA) numbers are required to be

issued by Continental prior to returning any Product for service, repair, credit or exchange. Continental warrants that its Products shall be free from defects in materials and workmanship for a period of one year from date of shipment of the product to purchaser. The warranty on 3rd party equipment such as terminals, printers, and communications devices shall be 1 year from date of shipment. Remediation of this warranty shall be limited to the repair or replacement of those products which are defective or become defective under normal use. Continental's warranty shall not extend to any product which is found after examination to be defective as a result of misuse, improper storage, incorrect installation, operation or maintenance, alteration, modification or accident.

There are no other warranties which extend beyond this provision. This warranty is in lieu of all other warranties whether express, implied or statutory, including implied warranties of merchantability or fitness for any particular purpose. No representation or warranty of the distributor shall extend the liability or responsibility of the manufacturer beyond the terms of this provision. In no event shall Continental be liable for any costs, loss of profits, loss of use, incidental, consequential or special damages to any person resulting from the use of Continental's products.

The above limited warranty is the only warranty provided by Continental. Continental makes no other warranties or guarantees, whether expressed or implied, including, but not limited to, warranties and/or guarantees of merchantability or fitness for a particular purpose. In no event shall Continental be liable for any indirect, consequential or incidental damages, including those to person and those for lost wages, or other economic loss.

Product Liability

Continental's sole Liability and the customer's exclusive remedy for damages, shall not exceed the cost of correcting the defect and in no event shall such liability be greater than the purchase price paid by the customer for the defective equipment or software. Under no Circumstances will Continental be liable for direct, indirect or consequential damages of any kind.

General Notices:

In order to assure that Continental's customers receive the most accurate and reliable information possible, Continental at times monitors telephone calls

Information and pricing contained within this document are subject to change without notice.

Continental does not recommend that these products be used as the primary means of monitoring, warning or egress. Primary warning or monitoring systems should always meet local fire and safety code requirements.

This transaction shall be governed and construed in accordance with the laws of the State of New York.

Continental specifically rejects any terms or conditions stated by the customer or contained within purchase documents or correspondence from the customer which are in addition to, conflict with or limit, terms or conditions set forth herein. The customer's execution or other acceptance of this proposal or its acceptance of delivery of all or part of the goods to be delivered hereunder shall constitute customer's acceptance of the terms and conditions herein and shall be deemed to exclude any additional, conflicting or limiting terms stated by customer or contained in customer's purchase documents or correspondence.

Continental **Access**



A NAPCO SECURITY GROUP COMPANY

355 Bayview Avenue, Amityville, NY 11701
Phone: 631-842-9400 Fax: 631-842-9135

www.cicaccess.com

Publicly traded on NASDAQ Symbol: NSSC