

OSM-1000-BRD Quick Start Guide

OSDP-Wiegand Converter

What is included:

- OSM-1000-BRD (board only)
- Warranty
- Quick Start Guide

Product Overview:

The OSM-1000-BRD (board only) OSDP-Wiegand Converter is a general purpose Wiegand / OSDP converter. The OSM unit has two operating modes, PD (Peripheral Device) mode and ACU (Access Control Unit) mode. In PD mode, the OSM unit connects a traditional Wiegand reader to an OSDP ACU. In ACU mode, the OSM unit connects an OSDP reader to a traditional Wiegand Access Controller. Additionally, two OSM-1000 units can be used together, one in ACU mode and the other in PD mode, to connect a Wiegand reader to a Wiegand Access Controller with an OSDP connection in between.

Pin Designations:

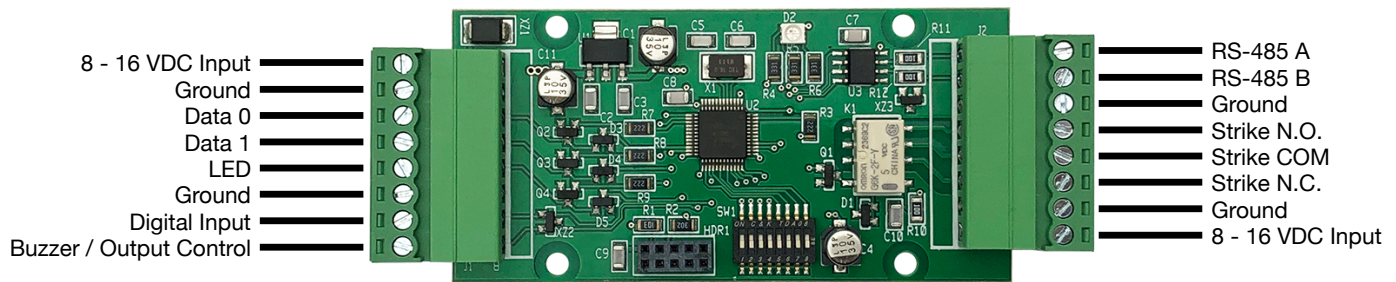

DIP Switch Settings:

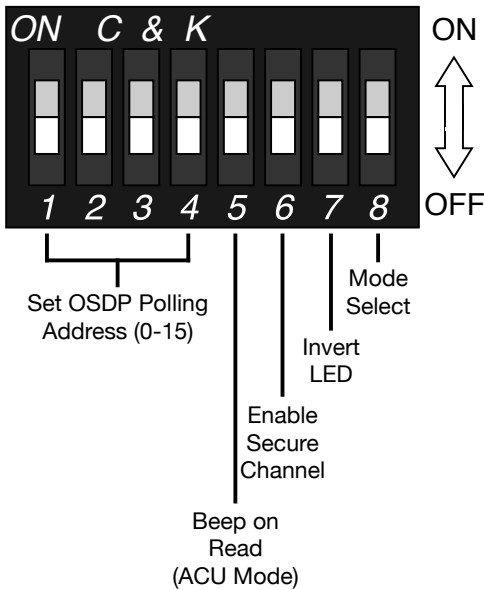

DIP Switches 1-4: Set the OSDP Polling Address in PD mode. Set the OSDP Address to be polled by the OSM unit in ACU mode. See the DIP Switch Address Table to the right.

DIP Switch 5: When ON, enables the Beep on Read feature when in ACU mode.

DIP Switch 6: When ON, enables Secure Channel communication.

DIP Switch 7: When ON, inverts `osdp_LED` command sent to PD when in ACU mode; and inverts the state of the output pin based on `osdp_LED` command received in PD mode.

DIP Switch 8: When ON, the OSM-1000 is set to ACU mode. When OFF, the OSM-1000 is set to PD mode.

1	2	3	4	Address #
				Address 0
X				Address 1
	X			Address 2
X	X			Address 3
		X		Address 4
X		X		Address 5
	X	X		Address 6
X	X	X		Address 7
			X	Address 8
X		X	X	Address 9
X	X	X		Address 10
		X	X	Address 11
X		X	X	Address 12
	X	X	X	Address 13
X	X	X	X	Address 14
X	X	X	X	Address 15
X = ON				

OSDP Default Parameters:

Secure Channel Key: 303132333435363738393A3B3C3D3E3F
 Polling Address: 0
 Baud Rate: 9600

For more detailed information on the OSM-1000 visit CypressIntegration.com.

ACU Mode Wiring Diagram

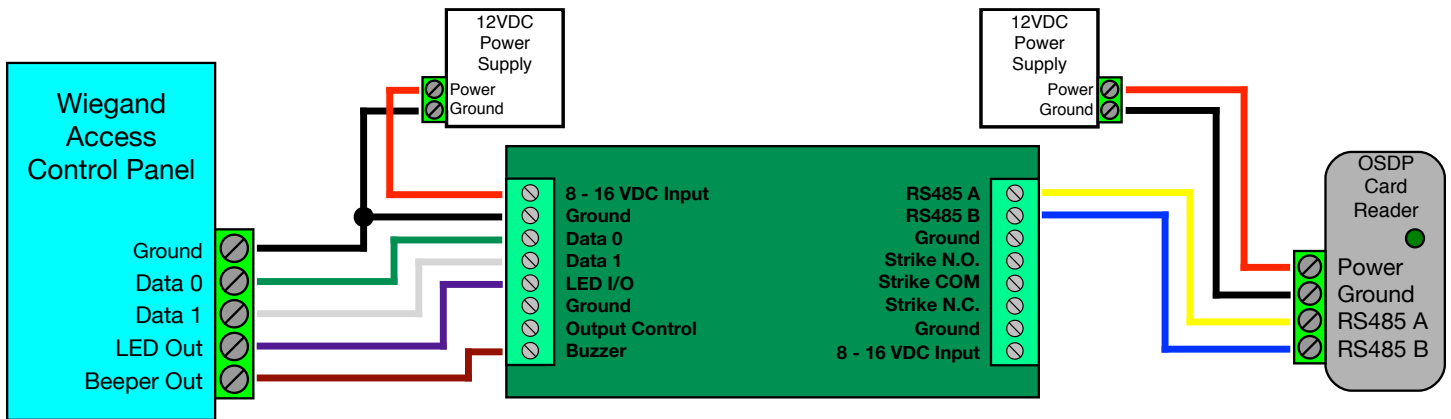

PD Mode Wiring Diagram

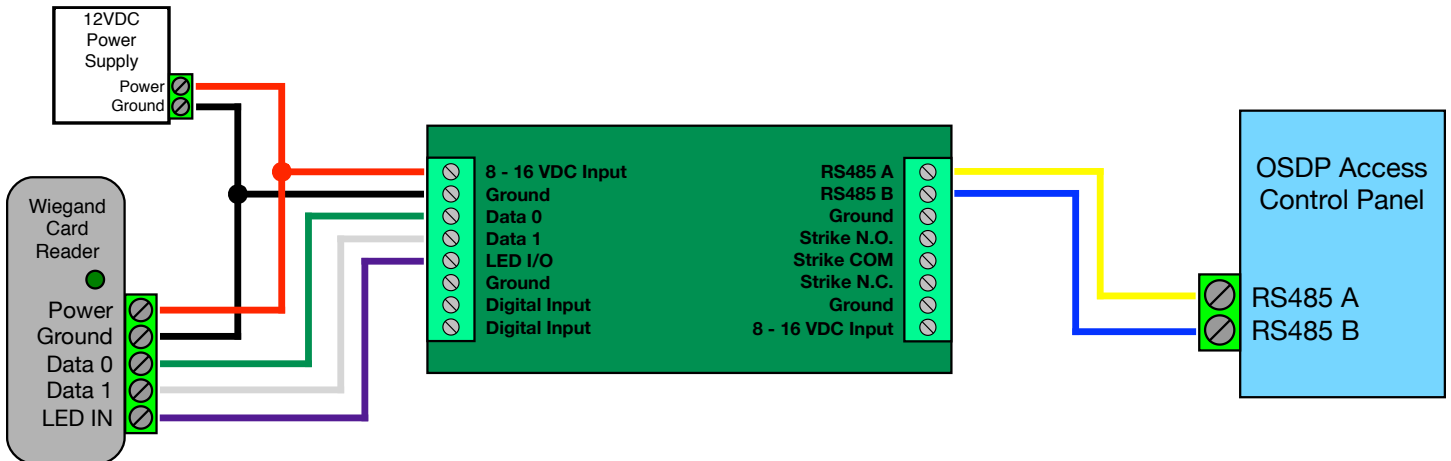

Status LED Behavior:

The OSM-1000-BRD unit has a tri-color LED that can display red, green, blue, and white. The startup sequence lasts approximately 5 seconds and the LED will display red, blue, green, white or display red, green, blue, white.

ACU Mode:

Communication with PD: the status LED will be blue with fast, green flashes or green with fast, blue flashes. The status LED will briefly turn red when it receives reader data from the PD.

No Communication with PD: the status LED will be blue with slow, green flashes or green with slow, blue flashes. The status LED will briefly turn red when it receives reader data from the PD.

PD Mode:

Communication with ACU: the status LED will red with fast, blue flashes or red with fast, green flashes.

No communication with ACU: the status LED will slowly fade from red to off, and back to red.

Bench Testing: Bench testing is recommended to avoid troubleshooting issues in the field.

ACU Mode:

1. At the bench, connect the OSM unit to the PD and the Wiegand access controller by following the ACU Mode Wiring Diagram.
2. Observe the OSM unit and PD communicating. Refer to the "Status LED Behavior" section to verify that the OSM unit is communicating with the PD.
3. If the devices do not communicate, make sure the the baud rate and polling ID match. In the OSDP spec, the default baud rate is 9600 and the default polling ID is 0.

PD Mode:

1. At the bench, connect the OSM unit to the Wiegand reader and ACU by following the PD Mode Wiring Diagram.
2. Observe the OSM unit and ACU communicating. Refer to the "Status LED Behavior" section to verify that the OSM unit is communicating with the ACU.
3. If the devices do not communicate, make sure the the baud rate and polling ID match. In the OSDP spec, the default baud rate is 9600 and the default polling ID is 0.