

Double wall-mount bracket for LED illuminators

DW-ILWM2



WHAT'S IN THE BOX

1x double mount bracket

4x M6 serrated flanged nut

4x M6 x 0.47" (12mm) bolt

1x quick set up guide

NOTE: Download all your support materials and tools in one place.

1. Go to: <http://www.digital-watchdog.com/resources>.
2. Search for your product by entering the part number in the **'Search by Product'** search bar. Results for applicable part numbers will populate automatically based on the part number you enter.
3. Click **'Search'**. All supported materials, including manuals and quick start guide (QSGs) will appear in the results.



Attention: This document is intended to serve as a quick reference for initial set up.

It is recommended that the user read the entire instruction manual for complete and proper installation and usage.

INSTALLING THE MOUNT BRACKET

Attach the wall mount bracket to the structure using suitable tapping screws (PLASTIC ANCHOR, PTS1 M8x40L) as illustrated in figure 1 below. The wall bracket must be attached to a structure such as hardwood, wall stud, concrete or a suitable material capable of supporting the final mount assembly. You may need to change the method of mounting or hardware used depending on the wall material.

LED ILLUMINATOR INSTALLATION WITH DOUBLE WALL MOUNT BRACKET

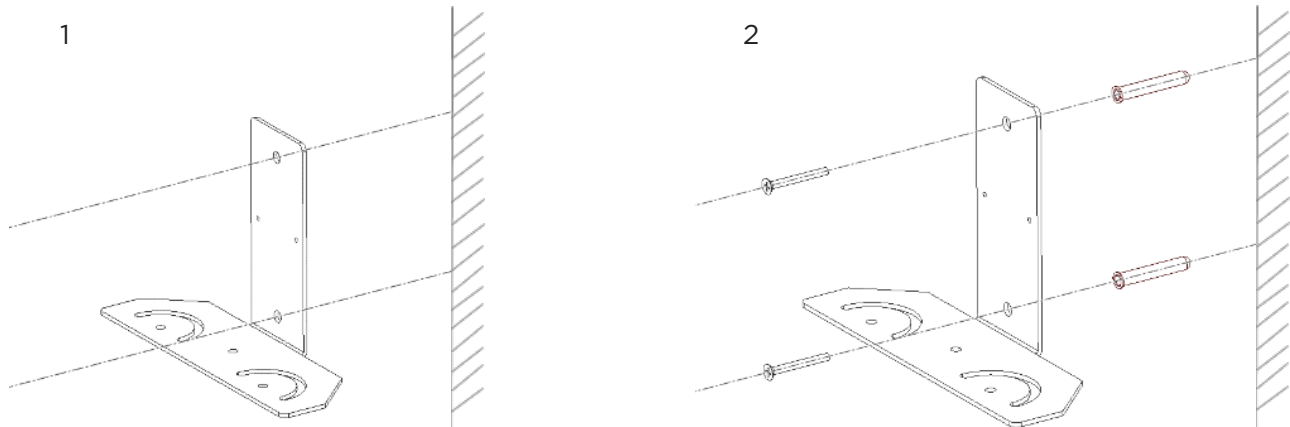

Use the bracket to mark and drill the necessary holes in the wall.

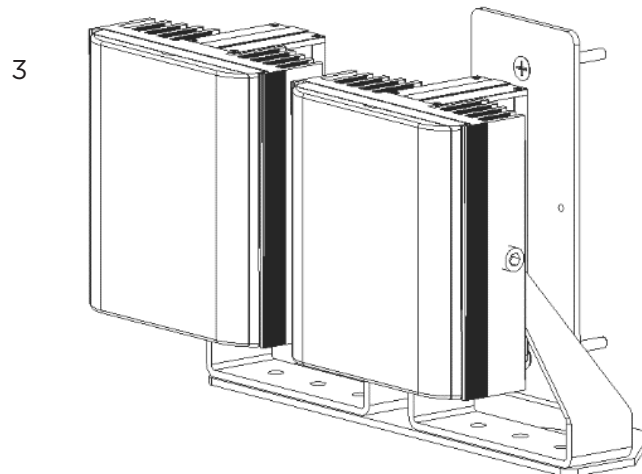

With the bracket secured to the wall, attach the illuminators with the supplied M6 nuts and bolts. For each illuminator, attach the center bolt first then rotate the illuminators to the required horizontal position. Once the necessary position is achieved, secure the illuminators with the remaining nut and bolt in one of the outer holes.

Vertical adjustment can be made via the two hex bolts on each side of the illuminator.

A waterproof junction box is attached to the bracket's rear plate. This allows for a single power cable to be routed to the junction box and then split to each illuminator. This can be removed if not required.

- NOTE:** Recommended fasteners:
- Head size: minimum 0.6"
 - Screw or bolt diameter: maximum 0.5"
 - Fastener strength: minimum 6 lb.