

DWC-B6853WTIR



WHAT'S IN THE BOX

Hex Allen wrench		1	Mounting template		1
Test video cable		1	Moisture absorber and absorber guide		1
Sunshield cover and adjusting screws		1	Quick setup guide		1
Screws and plastic anchors (4pcs)		1 Set			

**NOTE:** Download all your support materials and tools in one place.

- Go to: <http://www.digital-watchdog.com/resources>
- Search your product by entering the part number in the 'Search by Product' search bar. Results for applicable part numbers will populate automatically based on the part number you enter.
- Click 'Search'. All supported materials, including manuals and quick start guide (QSGs) will appear in the results.



**Attention:** This document is intended to serve as a quick reference for the initial setup. It is recommended that the user read the entire instruction manual for complete and proper installation and usage.

STEP 1 - PREPARING TO MOUNT THE CAMERA

- The mounting surface must withstand five times the camera weight.
- Do not let the cables get caught in improper places or the electric line cover can be damaged. This may cause a short or fire.
- Install the moisture packet in the base of the camera's lens.
  - Remove the moisture absorber from the packaging.
  - Cut the card and folder along the dotted line.
  - Place the moisture absorber behind the camera's lens module. See the drawing for more information.
- Using the mounting template sheet or the camera itself, mark and drill the necessary holes in the wall or ceiling.



✂ Please cut the card type absorber along a dotted line, overlap and attach them according to the direction of the arrow.

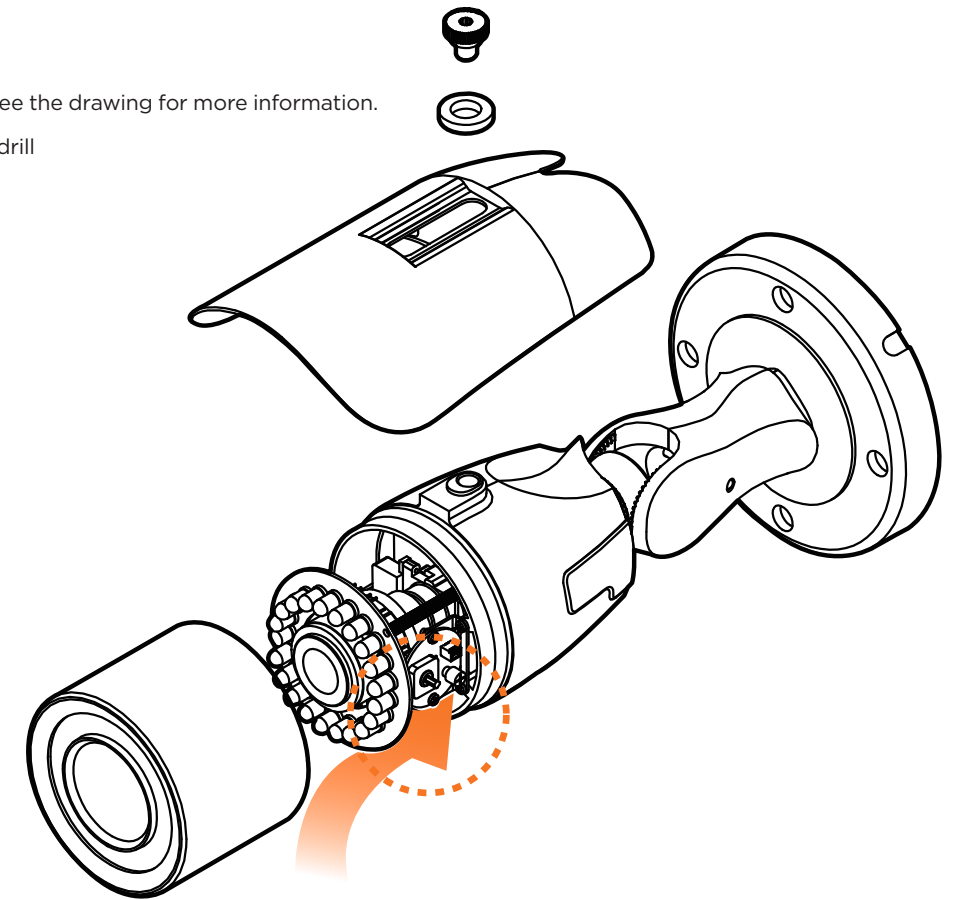

STEP 2 - CABLING THE CAMERA TO EXTERNAL DEVICES

Pass the wires through the mount bracket and make all necessary connections. Connect the BNC cable and power cables to the camera.

Power requirements	Power consumption
DC12V	DC12V (LED off): 3W (250mA) DC12V (LED on): 4.2W (352mA)

### STEP 3 - CHANGING THE SIGNAL IN THE CAMERA

1. The camera supports HD-Analog, HD-CVI and HD-TVI signals as well as CVBS up to 960H. To switch between the signals:
  - a. Enter the camera's OSD menu. You can access it locally from using the camera's joystick in the body of the camera, or from a recorder supporting UTC communication. Go to SETUP > OUTPUT.
  - b. Set the camera's resolution from the following options:
    - 4K/2160p @15fps.
    - 5MP/1440 @30fps.
    - 2.1MP/1080p @30fps.
  - c. Set the camera's analog signal output from the following options:
    - HD-A - HD-Analog
    - HD-T - HD-TVI
    - HD-C - HD-CVI
    - CVBS - legacy analog signal
  - d. Change CONFIRM to ON to save the changes.
  - e. Go to the EXIT menu and select SAVE&EXIT to save all changes. The camera signal automatically.

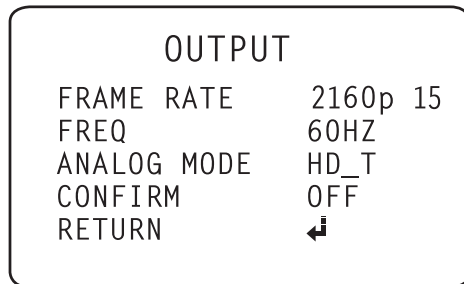

### STEP 4 - INSTALLING THE CAMERA

1. Once all cables have been connected, use the screws included with the camera to properly mount and secure the camera to the mounting surface.
2. To adjust the camera's tilt, loosen the screws at the base of the camera's bracket. The camera's max angles are:
  - Pan: 0°- 360°
  - Tilt: 0°- 90°

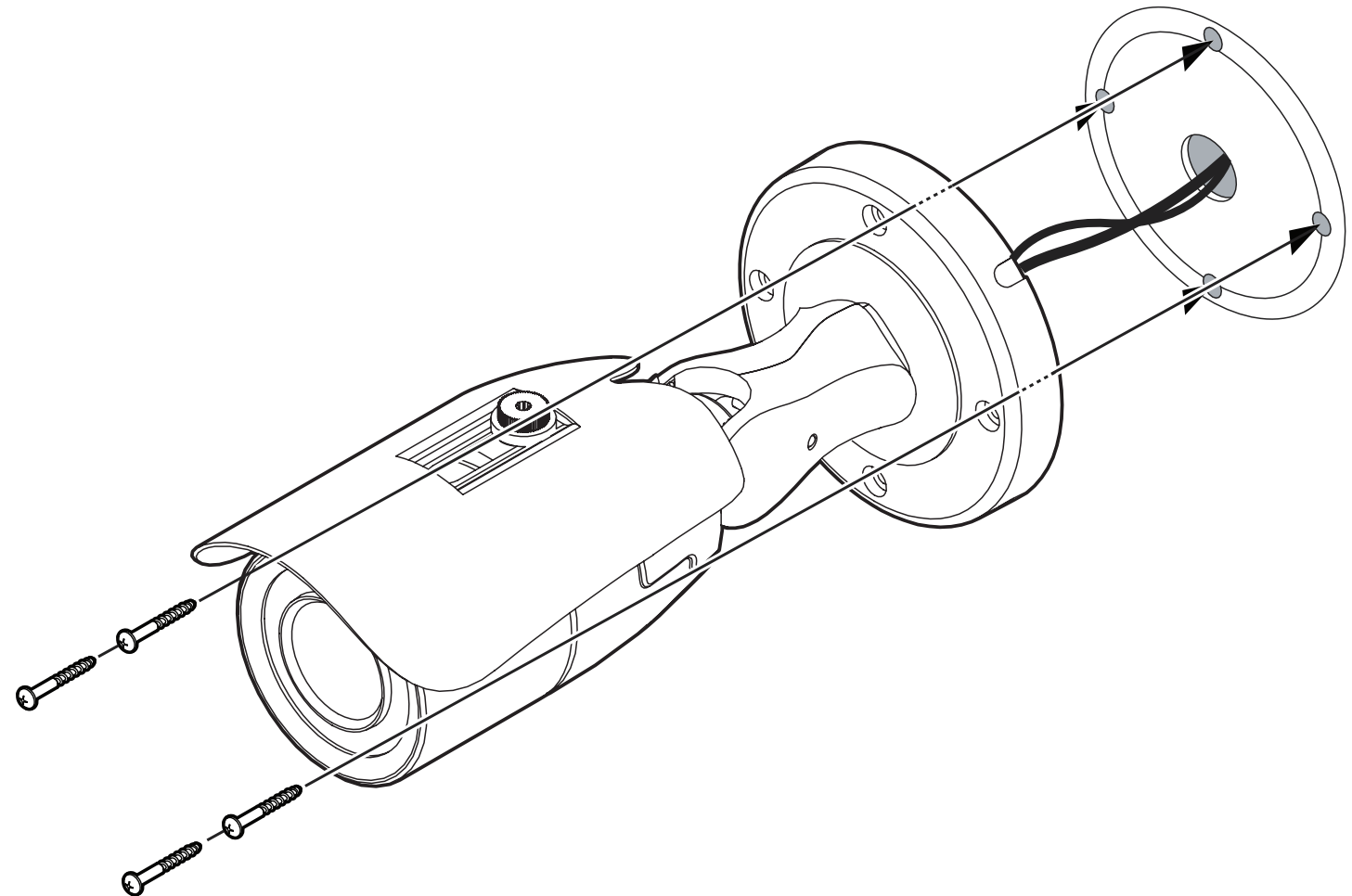

**NOTE:** To use your Star-Light Plus™ 4K cameras at a lower resolution, you must use a VMAX® A1 4K DVR to access the camera's menu due to the cameras being set to 4K as the default. A DVR that does not support 4K resolution may recognize the camera, but will not deliver a picture.