

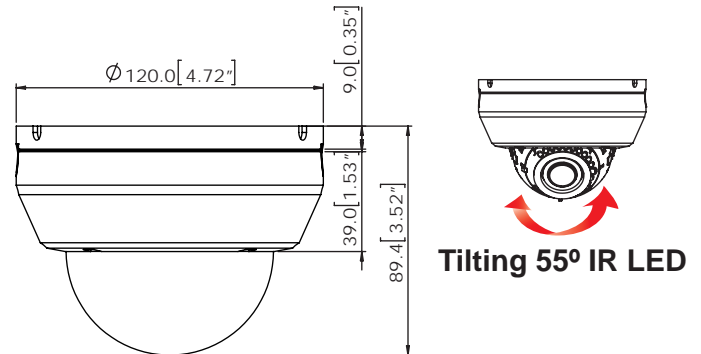

Dimensions (unit : mm)



Summary

Our WDR CMOS Series is our new ultimate Wide Dynamic Range camera line equipped with a powerful CMOS sensor chip, offering the most powerful Wide Dynamic Range feature in the market. The cameras are perfect for any project where cameras face harsh lighting conditions, with very dark and very bright areas in the same field of view. By capturing the dark and bright areas separately and then interlacing the image, you are able to utilize one camera to view all the details in complex Fields of View.

Features

- 1/3" 760H CMOS Sensor Chip (760 Horizontal Pixels)
- 690TVL
- 2.8~12mm Varifocal Auto Iris Lens
- 100ft Range IR with Intelligent Camera Sync
- TDN (True Day & Night) with IR Cut Filter
- WDR (Wide Dynamic Range)
- 2D DNR (2D Digital Noise Reduction)
- Smear Cancellation
- AGC / AWB
- Easy Icon Driven OSD Menu with Built-in Joystick
- Auto Sensing 24VAC/12VDC

Specifications

VIDEO	
Image Sensor	760H CMOS
Total Pixels	756(H) X 504(V)
Scanning System	2 : 1 Interlace
Frequency	15.734KHz (H), 59.95Hz (V)
Synchronization	Internal
Horizontal Resolution	690 TV Lines
Minimum Illumination	F1.2 (30IRE): 0.0 Lux
S/N Ratio	58dB (AGC off)
Video Output	CVBS: 1.0Vp-p / 75 Ω
LENS	
Focal Length	2.8~12 mm
Lens Type	Varifocal Auto Iris Lens
IR Distance	100ft Range IR
OPERATIONAL	
Shutter Speed	1/60~1/66,000, AUTO
Brightness	1~10
WDR	Low / Middle / High
Auto Gain Control	Low / Middle / High
DNR	Level 1 ~ 3
White Balance	ATW/ OUTDOOR/ INDOOR
Day and Night	AUTO/ COLOR/ EXT
Mirror	NONE/ H/ V/ H,V
Contrast	1~10
Sharpness	1 ~ 10
White Level	1~10
ENVIRONMENTAL	
Operating Temperature	-10°C ~ 50°C (14°F ~ 122°F)
Operating Humidity	Less than 90% (Non-Condensing)
ELECTRICAL	
Power Requirement	Dual Voltage (DC12V, 24VAC)
Power Consumption	DC12V: 1.8W, 150mA, LED On: 4.3W, 358mA AC24V: 1.8W, 75mA, LED On: 4.3W, 158mA
MECHANICAL	
Housing Material	Plastic
Dimensions	120 x 89.4 mm (4.7 X 3.52 in)
Weight	0.5 lbs

*Specification is subject to change without prior notice.