

Get the details you've been missing!



Main Features

- 1/2.8" CMOS Sensor
- 2.1 Megapixels (1920X1080)
- 4.0 mm Fixed Lens
- TDN (True Day and Night/IR Cut Filter)
- WDR (Wide Dynamic Range)
- 3D-DNR (3D Digital Noise Reduction)
- 30ft Range Intelligent Smart IR
- IP66 Certified (Weather Resistant)

HF21M4TIR

High Definition 2.1 Megapixel Camera



Dimensions (unit : mm)

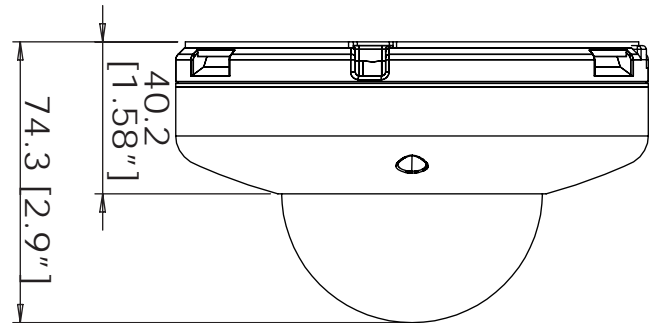

Summary

The HF21M4TIR is a 2.1 megapixel indoor dome camera with HD-SDI 1080P output. SDI technology serializes the video signal and transmits it uncompressed, eliminating distance and deformation issues that may affect the camera's image quality, making the image quality a true High Definition. The camera outputs the clearest high definition images with features like 3D Digital Noise Reduction and Wide Dynamic Range. DW's HD-SDI cameras allow you to enhance your security system to full HD 1080P resolution while still using existing coax installation. DW's HD-SDI line offers a reliable high quality yet affordable camera in just a few minutes.

Features

- 1/2.8" CMOS Sensor
- Highest Resolution 2.1 Megapixels (HD-SDI)
- 4.0mm Fixed Lens
- 12x Digital Zoom
- 30ft Range IR with Intelligent Camera Sync
- TDN (True Day and Night/IR Cut Filter)
- WDR (Wide Dynamic Range)
- 3D-DNR (3D Digital Noise Reduction)
- IP66 Certified (Vandal Proof)

Specifications

VIDEO	
Image Sensor	1/2.8" CMOS Sensor
Total Pixels	2000 (H) x 1241 (V)
Synchronization	Internal
Resolution	2.1 Megapixels (1920 x 1080) at 30fps
Minimum Illumination	0.0 Lux (IR On)
S/N Ratio	50dB (AGC off)
Video Output	HD-SDI
LENS	
Focal Length	4.0mm
Lens Type	Fixed Lens
IR Distance	30ft Range IR
ENVIRONMENTAL	
Operating Temperature	-10°C ~ 55°C (14°F ~ 131°F)
Operating Humidity	Less than 90% (Non-Condensing)
IP Rating	IP66 (Protects against dust and high pressure water.)
ELECTRICAL	
Power Requirement	DC12V
Power Consumption	LED Off: 2.0W, 166.7mA / LED ON: 2.7W, 225mA
MECHANICAL	
Housing Material	Aluminum Die-casting
Dimensions	ø 125 x 74.3mm (ø 4.9 x 2.9")
Weight	1 lbs

*Specification is subject to change without prior notice.

Accessories (Optional)



DWC-VFZWM
Wall Mount for VF and PTZ5x Models