



- DWC-MV84WiAC6 - 64GB storage
- DWC-MV84WiAC1 - 128GB storage
- DWC-MV84WiAC2 - 256GB storage



Default Login Information	
Username: admin	Password: admin



WHAT'S IN THE BOX

Quick setup guide		1	Test video cable		1
Mounting template for bolt and nuts installation		1	Waterproof cap		1 set
Mounting template for plate installation		1	Hex Allen wrench		1
Bolt and nuts 2pcs		1 set	Screws and plastic anchors 3pcs		1 set
Metal mounting plate		1	Moisture absorber and installation guide		1 set

NOTE: Download all your support materials and tools in one place.

- Go to: <http://www.digital-watchdog.com/resources>
- Search your product by entering the part number in the 'Search by Product' search bar. Results for applicable part numbers will populate automatically based on the part number you enter.
- Click 'Search'. All supported materials, including manuals and quick start guide (QSGs) will appear in the results.



Attention: This document is intended to serve as a quick reference for the initial setup. It is recommended that the user read the entire instruction manual for complete and proper installation and usage.

STEP 1 - PREPARING TO MOUNT THE CAMERA

- The mounting surface must withstand five times the camera weight.
- Do not let the cables get caught in improper places or the electric line cover can be damaged. This may cause a short or fire.
- CAUTION:** These servicing instructions are for use by qualified service personnel only. To reduce the risk of electric shock do not perform any servicing other than that contained in the operating instructions unless you are qualified to do so.
- This product is intended to be supplied by a UL Listed Power Supply Unit marked "Class 2" or "LPS" or "PS2" and rated 12 Vdc, 590 mA min.
- The wired LAN hub providing power over the Ethernet (PoE) in accordance with IEEE 802-3af shall be a UL Listed device with the output evaluated as a Limited Power Source as defined in UL60950-1 or PS2 as defined in UL62368-1.
- Unit is intended for installation in a Network Environment 0 as defined in IEC TR 62102. As such, associated Ethernet wiring shall be limited to inside the building.
- For the installation process, remove the dome cover from the camera module by loosening the three (3) screws on the dome. Use the wrench provided with the camera. Remove the protective film from the camera before the installation.
- Install the moisture packet in the base of the camera's lens.
 - Remove the moisture absorber from the packaging.
 - Cut the card and folder along the dotted line.
 - Place the moisture absorber behind the camera's lens module

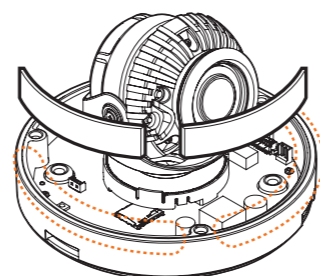

- Using the mounting template sheet or the camera itself, mark and drill the necessary holes in the wall or ceiling.

STEP 2 - CABLING THE CAMERA TO EXTERNAL DEVICES

Pass the wires through the mount bracket and make all necessary connections.

- NETWORK CONNECTIONS** - If you are using a PoE Switch, connect the camera using an Ethernet cable for both data and power.

- NETWORK CONNECTIONS** - If you are using a non-PoE switch, connect the camera to the switch using an Ethernet cable for data transmission and use a power adapter to power the camera.

Power requirements	Power consumption
DC12V POE (IEEE 802.3af Class 3). Adapter not Included.	DC12V: Max 7.1W PoE: Max 9.2W

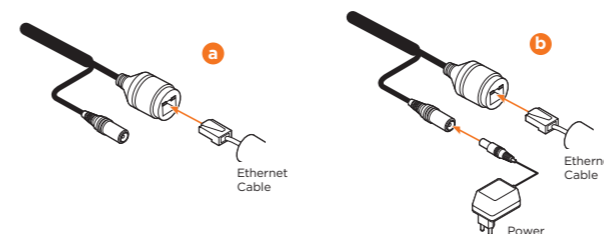

STEP 3 - INSTALLING THE CAMERA

- Attach the main body to the mount bracket by tightening the lock screw.
- For soft installation surfaces, use the included metal mount plate. Fix the mount plate on the mounting surface using the included screws. Then, press the bottom case onto the mount plate. The three bezels on the case will align and snap lock onto the plate.
- To use the camera's water proof wiring:
 - Install the LAN cable into **a**.
 - b** will be assembled to **a** with a 1/4 turn.
 - Thread **c** tightly to **b**.

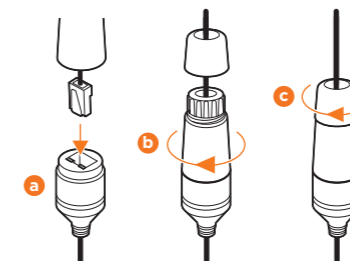

NOTE: To ensure moisture seal, make sure the o-ring is in place between **a** and **b**. In extreme environments use of an outdoor rated sealer is recommended.

NOTE: When using the waterproof cap, crimp the RJ45 connector after passing the cable through the waterproof cap.

- Use the camera's 3-Axis gimbal to adjust the camera's tilt and angle. The camera's maximum tilting angle is 75°.
- Insert the moisture pack behind the dome according to the instructions. Assemble the dome cover over the camera body and detach the protecting film from the dome bubble to complete the installation.

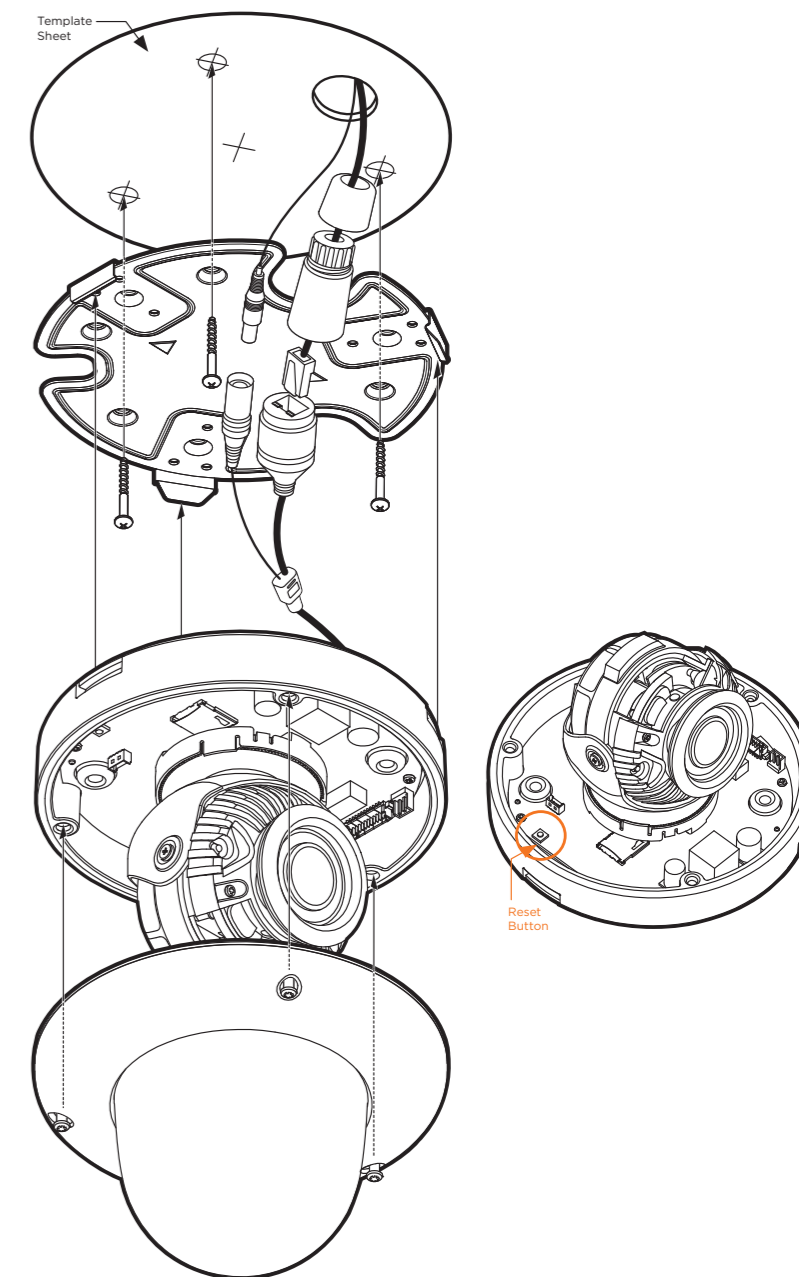

WARNING DO NOT TOUCH THE SURFACE OF BUBBLE. CleanView™ Hydrophobic Dome Coating has been applied to the camera's dome.

Resetting the camera: To reset the camera, use the tip of a paper clip or a pencil and press the reset button. Pressing the button for five (5) seconds will initiate a camera-wide reset of all the settings, including network settings.

STEP 3 - INSTALLING THE CAMERA (CONT.)

Installation using the mounting bolt and screws:

- Using the template sheet, make and drill the cabling holes on the mounting surface.
- Secure the two long mounting screws to the camera's base.
- Pass the wires through the mount bracket and make all necessary connections.
- Mount the camera to the mounting surface by using the 2 mounting nuts. Rotate the locking discs over the screws until the camera is held tightly from the mounting surface.

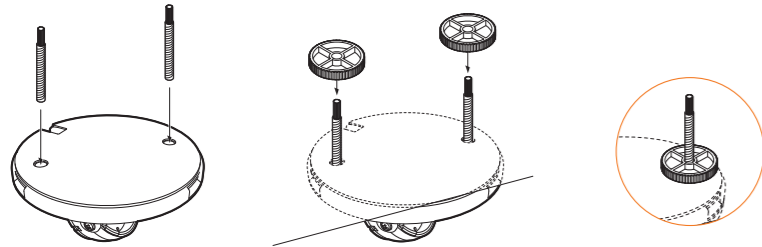

NOTE: The camera's maximum tilting angle is 75°

WARNING DO NOT TOUCH THE SURFACE OF THE BUBBLE. CleanView™ Hydrophobic Dome Coating has been applied to the camera's dome.

STEP 4 - DW® IP FINDER™

Use the DW® IP Finder™ software to scan the network and detect all MEGApix® cameras, set the camera's network settings or access the camera's web client.

Thumbnail view

Select network to scan

Filter device type to scan

Scan devices

Show/hide thumbnail view

Refresh thumbnail view

Bulk IP assignment

Firmware upgrade

Name	IP Address	Model	MAC Address	Netmask	Gateway	Port	DHCP	Version	Ping Test	IP Conf.	Uptime
DWC-MPTZ30X	192.168.150.34	DWC-MPTZ30X	00:07:0B:19:10:1A	255.255.255.0	192.168.150.1	80	Disabled	1.9.94-X2_release	Ping	Click	--
DWC-MV44WA	192.168.150.40	DWC-MV44WA	00:0D:F1:21:53:8F	255.255.255.0	192.168.150.1	80	Disabled	A2.01.02_20180619	Ping	Click	28day 14hrs 1mins
DWC-PZ21M69T	192.168.150.41	DWC-PZ21M69T	00:0D:F1:21:29:21	255.255.255.0	192.168.150.1	80	Disabled	A5.01.03_20180403	Ping	Click	39day 15hrs 54mins
DWC-PVX16W4	192.168.150.42	DWC-PVX16W4	00:0D:F1:21:5C:AD	255.255.255.0	192.168.150.1	80	Disabled	S2.01.03_20180309	Ping	Click	56day 16hrs 46mins
DWC-PFS1M1TR	192.168.150.61	DWC-PFS1M1TR	00:0A:61:1A:00:14	255.255.255.0	192.168.150.1	80	Disabled	-	Ping	Click	--
DWC-PVF9M2TR	192.168.150.62	DWC-PVF9M2TR	00:0A:61:1A:26:E7	255.255.255.0	192.168.150.1	80	Disabled	-	Ping	Click	--
DWC-MF4W4	192.168.150.63	DWC-MF4W4	00:0D:F1:20:F8:60	255.255.255.0	192.168.150.1	80	Disabled	A2.01.02_20180619	Ping	Click	28day 14hrs 0mins

Firmware version

Camera's uptime

Open Device configuration settings

Device's information

Network setup:

- To install the DW® IP Finder™, go to: <http://www.digital-watchdog.com>
- Enter "DW® IP Finder™" on the search box at the top of the page and press Enter.
- Click on the DW® IP Finder™ from the search result and go to Software tab. Click on download icon to download the DW® IP Finder™ installation file.
- Run the installation file and follow the wizard to install the DW® IP Finder™. Open the DW® IP Finder™ and click 'Scan Devices'. It will scan the selected network for all supported devices and list the results in the table. During the scan, the DW® logo will turn gray.
- Select a camera from the list by double-clicking on the camera's image or clicking on the 'Click' button under the IP Conf. column. The pop-up window will show the camera's current network settings, allowing admin users to adjust the settings as needed.
- To access the camera's web page, click on 'View Camera Website'.
- To save the changes made to the camera's setting, input username and Password of the camera and click Apply. Click Scan Devices from the main screen again to display the updated information.

- Select DHCP if the internet service is dynamic IP. This will allow the camera to receive its IP address from the DHCP server.
- Select Static to manually enter the camera's IP address, (Sub) Netmask, Gateway and DNS information. The camera's IP must be set to "Static" if connecting to DW Spectrum® IPVMS.
- Contact your network administrator for more information.

Default TCP/IP information: DHCP

'Port Forwarding' has to be set in your network's router for external access to the camera.

Default ID / PW: admin / admin

NOTE: For security purposes, it is highly recommended to change your password after initial setup.

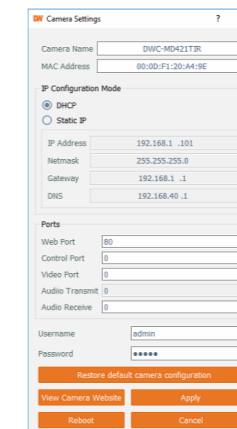

STEP 5 - WEB VIEWER

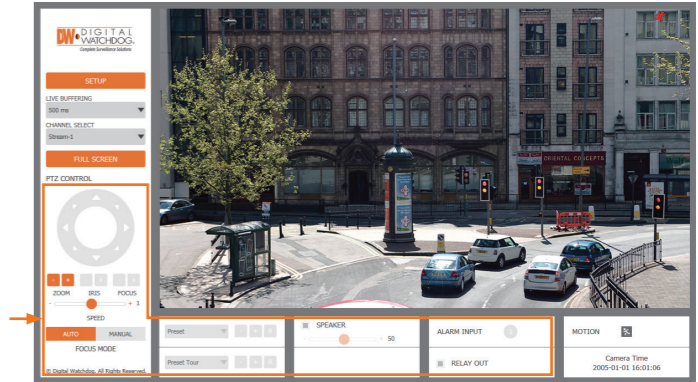

The GUI display may differ by camera models.

Once the camera's network settings have been setup properly, you can access the camera's web viewer using the DW® IP Finder™.

To open the camera's web viewer:

- Find the camera using the DW® IP Finder™.
- Double-click on the camera's view in the results table.
- Press the 'View Camera Website'. The camera's web viewer will open up in your default web browser.
- Enter the camera's username and password (default are admin / admin).
- If you are accessing the camera for the first time, install the VLC player for web files in order to view video from the camera.

NOTE: Some menu options may not be available based on the camera model. See the full manual for more information.

NOTE: Please see the full product manual for web viewer setup, functions and settings options.

STEP 6 - SETUP DW SPECTRUM® CAAS™ RECORDING

Once the CaaS™ camera is properly installed and operating, write down the IP address. You will need this information when accessing the DW Spectrum® CaaS™ server from the DW Spectrum® IPVMS client.

To complete the DW Spectrum® CaaS™ server's setup and start recording, launch the DW Spectrum® IPVMS client on the same network as the cameras. Once the DW Spectrum® CaaS™ server is detected by the client, go to the recording setup menu to setup a recording schedule and start monitoring the DW Spectrum® CaaS™ server.

Refer to the DW Spectrum® CaaS™ QSG for additional information.

NOTE: MEGApix® CaaS™ cameras are running DW Spectrum® IPVMS v4.0 server.

NOTE: Default server port: 7001
Default server username and password: admin | admin1234