



DWC-PVF5Di1TW



Default Login Information: admin | admin

When logging into the camera for the first time, you will be prompted to set up a new password. You can set the new password using the DW® IP Finder™ software or directly from the camera's browser menu.

WHAT'S IN THE BOX

Quick setup and download guides		1 set	Mount bolts and nuts - 2pcs		1 set
Metal mounting plate		1	Screws and plastic anchors - 3pcs		1 set
Mounting template for bolt and nut installation		1	Waterproof cap		1 set
Mounting template for metal plate installation		1	Hex Allen wrench		1

NOTE: Download all your support materials and tools in one place

- Go to: <http://www.digital-watchdog.com/resources>
- Search your product by entering the part number in the 'Search by Product' search bar. Results for applicable part numbers will populate automatically based on the part number you enter.
- Click 'Search'. All supported materials, including manuals and quick start guide (QSGs) will appear in the results.



Attention: This document is intended to serve as a quick reference for the initial setup. It is recommended that the user read the entire instruction manual for complete and proper installation and usage.

STEP 1 - PREPARING TO MOUNT THE CAMERA

- The mounting surface must bear five times the weight of your camera.
- Do not let the cables get caught in improper places or the electric line cover to be damaged. This may cause a breakdown or fire.
- Using the mounting template sheet or the camera itself, mark and drill the necessary holes in the wall or ceiling.

STEP 2 - CABLING THE CAMERA TO EXTERNAL DEVICES

Pass the wires through the mount bracket and make all necessary connections.

- NETWORK CONNECTIONS** - If you are using a PoE switch, connect the camera using an Ethernet cable for both data and power.
- NETWORK CONNECTIONS** - If you are using a non-PoE switch, connect the camera to the switch using an Ethernet cable for data transmission and use a power adapter to power the camera.

Power Requirements	Power Consumption
DC12V, PoE IEEE 802.3af Class 3 (Adapter not included)	DC12V: max 7.5W PoE: max 8.7W

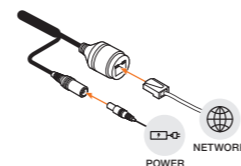

STEP 3 - INSTALLING THE CAMERA

- Once all cables are connected, secure the camera to the mounting surface using the included screws.
- For soft installation surfaces, use the included metal mount plate. Fix the mounting plate on the mounting surface using the included screws. Then, press the bottom case onto the mounting plate. The three bezels on the case will align and snap lock onto the plate.
- To use the camera's waterproof wiring:
 - Install the LAN cable into **a**.
 - b** will be assembled to **a** with a 1/4 turn.
 - Thread **c** tightly to **b**.

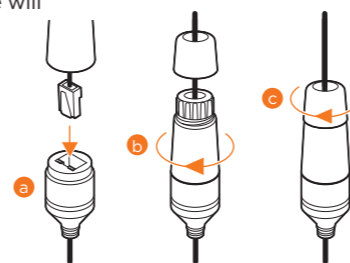

- Re-attach the camera's gasket ring and dome to the camera module by aligning the screw holes. Be sure to align the wedge on the side of the camera with the one on the mounting bracket.

Installation using mount bolt and screws:

- Using the template sheet for the nuts and bolts installation, mark and drill the holes on the mounting surface.
- Secure the two long mounting screws to the camera's base.
- Pass the wires through the mount bracket and make all necessary connections.
- Mount the camera to the mounting surface by using the 2 mounting nuts. Rotate the locking discs over the screws until the camera is held tightly from the mounting surface.
- Re-attach the camera's gasket ring and dome to the camera module by aligning the screw holes. Be sure to align the wedge on the side of the camera with the one on the mounting bracket.

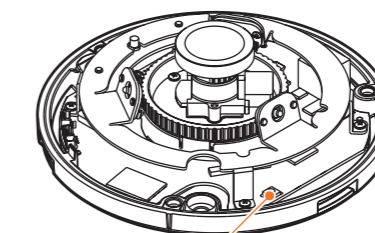
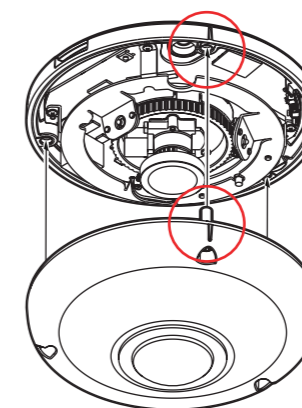
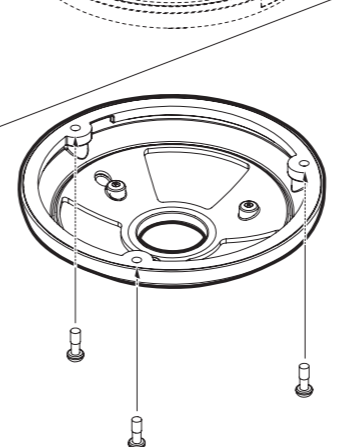
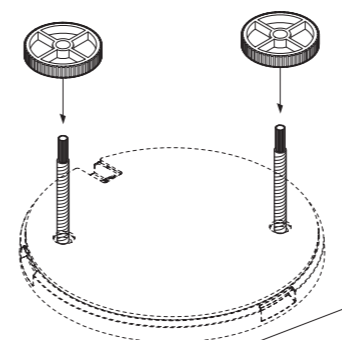

Reset Button

Resetting the camera: To reset the camera, use the tip of a paper clip or a pencil and press the reset button. Pressing the button for five (5) seconds will initiate a camera-wide reset of all the settings, including network settings.

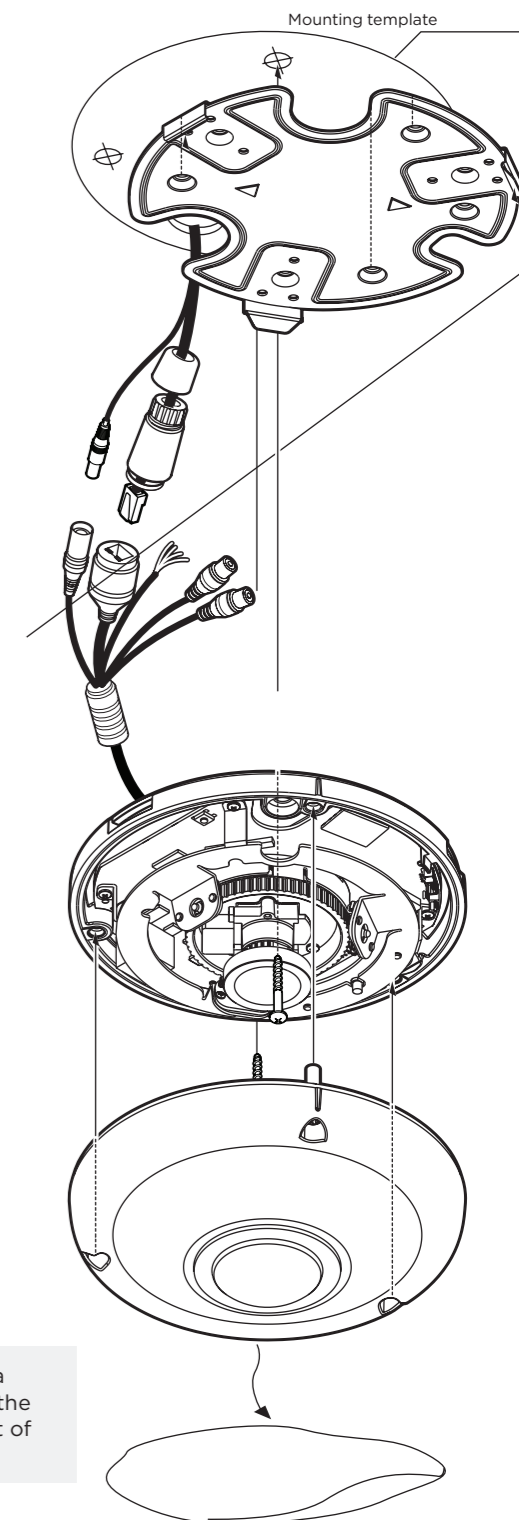

NOTE: To ensure moisture seal, make sure the o-ring is in place between **a** and **b**. In extreme environments use of an outdoor rated sealer is recommended.

NOTE: When using the waterproof cap, crimp the RJ45 connector after passing the cable through the waterproof cap.

STEP 4 - CABLING

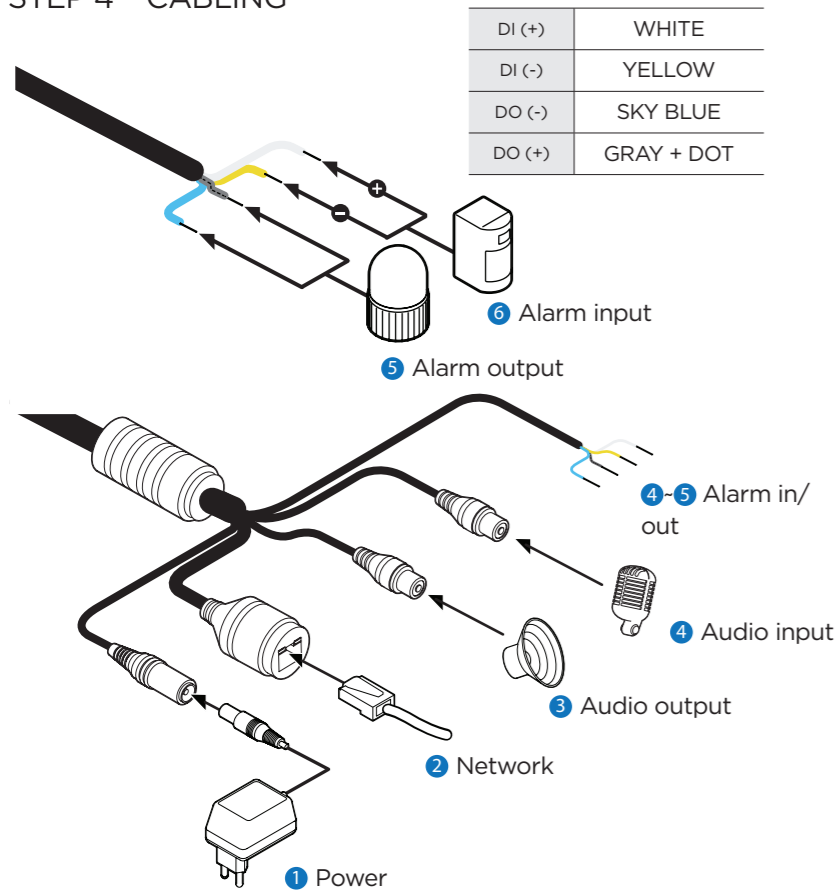

STEP 5 - MANAGING THE SD CARD

To install the memory card:

1. The SD card slot is located next to the reset button.
2. Detach the camera's cover dome from the camera's module by unscrewing the cover dome screws.
3. Insert a Micro SD/SDHC class 10 card according to the diagram.
4. To remove the SD card, press the card gently into the card slot to release it. The card will pop out automatically.

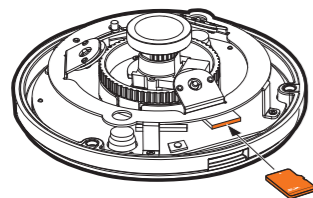

STEP 6 - DW IP FINDER™

Use the DW IP Finder™ software to scan the network and detect all MEGApix® cameras, set the camera's network settings or access the camera's web client.

Thumbnail view

Select network to scan

Filter device type to scan

Scan devices

Show/hide thumbnail view

Refresh thumbnail view

Bulk IP assignment

Firmware upgrade

Firmware version

Camera's uptime

Open Device configuration settings

Device's information

Network Setup

1. To install the DW IP Finder™, go to: <http://www.digital-watchdog.com>
2. Enter "DW IP Finder" on the search box at the top of the page and press Enter.
3. Click on the DW IP Finder from the search result and go to the Software tab. Click on the download icon to download the DW IP Finder installation file.
4. Run the installation file and follow the wizard to install the DW IP Finder™. Open the DW IP Finder™ and click 'Scan Devices'. It will scan the selected network for all supported devices and list the results in the table. During the scan, the DW logo will turn gray.

- 1 Select DHCP if the internet service is dynamic IP. This will allow the camera to receive its IP address from the DHCP server.
- 2 Select "Static" to manually enter the camera's IP address, (Sub) Netmask, Gateway and DNS information.
* The camera's IP must be set to Static if connecting to DW Spectrum
- 3 Contact your network administrator for more information.

1 Default TCP/IP information: DHCP

5. Select a camera from the list by double-clicking on the camera's image or click on the 'Click' button under the IP Conf. column. The pop-up window will show the camera's current network settings, allowing admin users to adjust the settings as needed.
6. To access the camera's web page, click on 'View Camera Website'.
7. To save the changes made to the camera's setting, input the username and password of the camera and click Apply. Click "Scan Devices" from the main screen again to display the updated information.

1 'Port forwarding' has to be set in your network's router for external access to the camera.

1 Default ID / PW : admin / admin

*NOTE: For security purposes, it is highly recommended to change your password after initial setup.

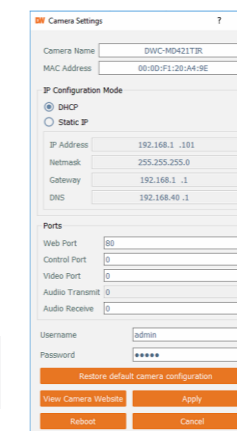

STEP 7 - WEB VIEWER

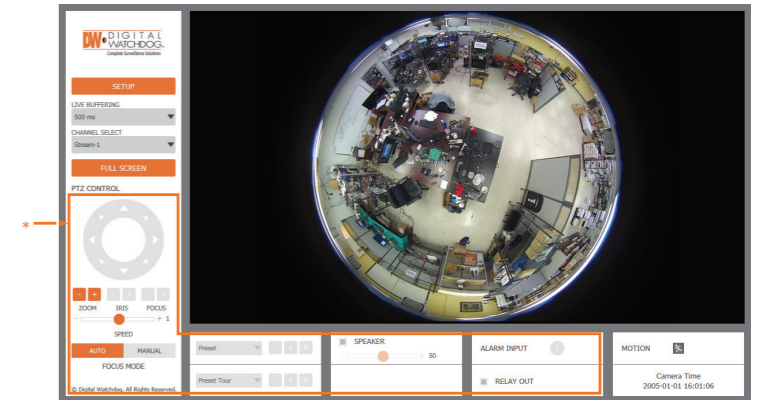

The GUI display may differ by camera models.

* NOTE: Some menu options may not be available based on the camera model. See the full manual for more information.

Once the camera's network settings have been setup properly, you can access the camera's web viewer using the DW® IP Finder™.

To open the camera's web viewer:

1. Find the camera using the DW® IP Finder™.
2. Double-click on the camera's view in the results table.
3. Press the 'View Camera Website'. The camera's web viewer will open up in your default web browser.
4. Enter the camera's username and password you setup in the DW® IP Finder™. If you did not setup a new username and password via the DW® IP Finder™, you will not be able to view video from the camera. A message will direct you to setup a new password for the camera in order to view video.

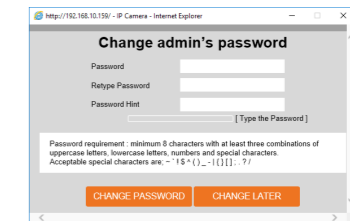

5. When accessing the camera for the first time, install the VLC player for web files in order to view video from the camera.

NOTE: 32bit version of VLC player must be installed. If you are using 64bit system, uninstall the previous 64bit version and reinstall using the 32bit version.

NOTE: Please see the full product manual for web viewer setup, functions and camera settings options.