

# Starlight MPA Vandal Dome Camera

DWC-V5661T

DWC-V5661TIR



## **ABOUT MANUAL**

Before installing and using the camera, please read this manual carefully.  
Be sure to keep it handy for future reference.

## PRECAUTIONS

---

- Do not open or modify.
- Do not open the case except during maintenance and installation, for it may be dangerous and can cause damages.
- Do not put objects into the unit.
- Keep metal objects and flammable substances from entering the camera.  
It can cause fire, short-circuits, or other damages.
- Be careful when handling the unit.
- To prevent damages, do not drop the camera or subject it to shock or vibration.
- Do not install near electric or magnetic fields.
- Protect from humidity and dust.
- Protect from high temperature.
- Be careful when installing near the ceiling of a kitchen or a boiler room, as the temperature may rise to high levels.
- Cleaning:  
To remove dirt from the case, moisten a soft cloth with a soft detergent solution and wipe.
- Mounting Surface:  
The material of the mounting surface must be strong enough to support the camera.

## FCC COMPLIANCE

---

This equipment has been tested and found to comply with the limits for a Class B digital device, pursuant to part 15 of the FCC rules. These limits are designed to provide reasonable protection against harmful interference, when the equipment is operated in a residential environment. This equipment generates, uses, and radiates radio frequency energy; and if it is not installed and used in accordance with the instruction manual, it may cause harmful interference to radio communications.

**WARNING:** Changes or modifications are not expressly approved by the manufacturer.

## TABLE OF CONTENTS

---

|                                   |                                   |       |
|-----------------------------------|-----------------------------------|-------|
| <b>Introduction</b> .....         | Features .....                    | 4     |
|                                   | Parts and Descriptions .....      | 5     |
|                                   | Dimensions .....                  | 6     |
| <b>Installation</b> .....         | Inside the Box .....              | 7     |
|                                   | Surface Mount Installation .....  | 8     |
|                                   | Accessories Installation .....    | 9-12  |
|                                   | Connecting to Monitors .....      | 13    |
|                                   | Control Board .....               | 14    |
|                                   | Adjusting the Camera Lens .....   | 15    |
|                                   | Adjusting the Camera Gimbal ..... | 16    |
| <b>Module OSD Menu</b> .....      |                                   | 17-29 |
| <b>Troubleshooting</b> .....      |                                   | 30    |
| <b>Warranty Information</b> ..... |                                   | 31-32 |
| <b>Specifications</b> .....       |                                   | 33-34 |

## FEATURES\*

- 1/3" Sony 1.3M CMOS
- 820 TV Lines [B/W], 800 TV Lines [Color]
- 2.8~12mm Varifocal Auto Iris Lens
- 100ft Range IR with Intelligent Camera Sync, Smart IR [DWC-V5661TIR]
- True Day & Night with IR Cut Filter
- 3D DNR (3D Digital Noise Reduction)
- WDR (Wide Dynamic Range)
- Star-Light (Super Low Light Technology)
- HME (Highlight Masking Exposure)
- Defog (Extreme Weather Image Compensation)
- Digital Quick Zoom & 8x Digital Zoom
- 16:9 and 4:3 Viewing Modes
- AGC / BLC / AWB
- Privacy Zones (16) & 4 Motion Detection Zones
- Camera Control via RS-485/ UTC
- RS485 & UTP Built-In
- RS485, UTP, & 1 Alarm Output Built-In
- IP66 Certified (Weatherproof)

## PARTS & DESCRIPTION\*

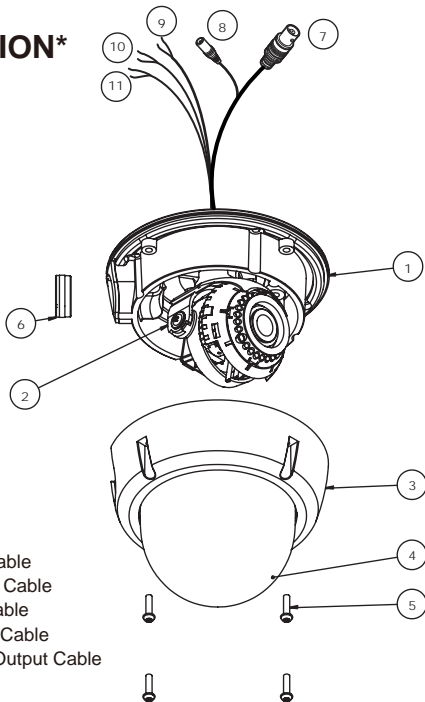

- |   |                       |   |                    |
|---|-----------------------|---|--------------------|
| ❶ | Bottom Case           | ❷ | BNC Cable          |
| ❷ | Camera Gimbal         | ❸ | DC12V Cable        |
| ❸ | Upper Case            | ❹ | UTP Cable          |
| ❹ | Dome Cover            | ❺ | RS485 Cable        |
| ❺ | Cover Screws (x4)     | ❻ | Alarm Output Cable |
| ❻ | Side Port for Cabling |   |                    |

## DIMENSIONS IN MILLIMETERS (IN)\*

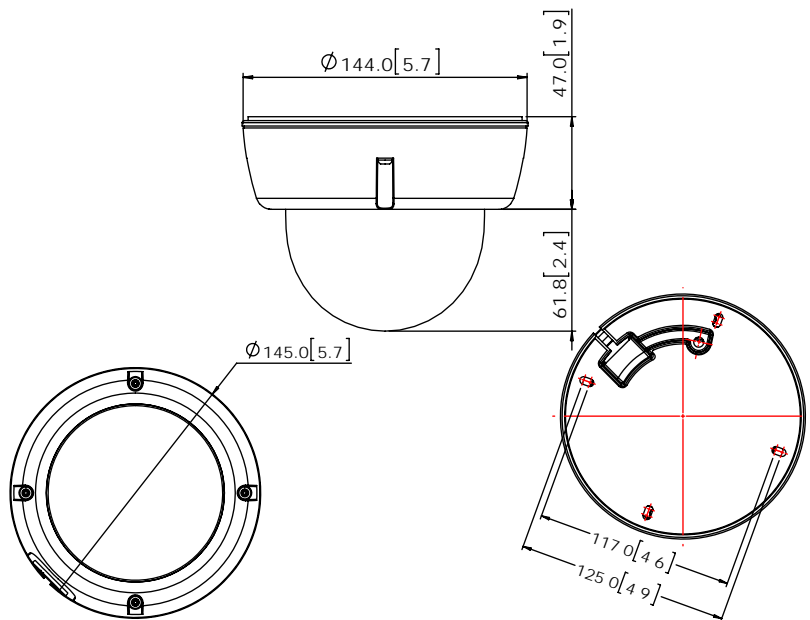

## INSIDE THE BOX\*

### Included with Camera:

- 1 User Manual
- 2 Mounting Template
- 3 4 Machine Screws and 4 Dry Wall Anchors
- 4 Secondary Video-BNC Cable
- 5 L-Key
- 6 DC Plug Power Cable



1

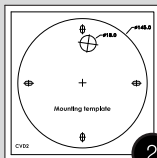

2



3



4



5



6

## SURFACE MOUNT INSTALLATION INSTRUCTIONS\*

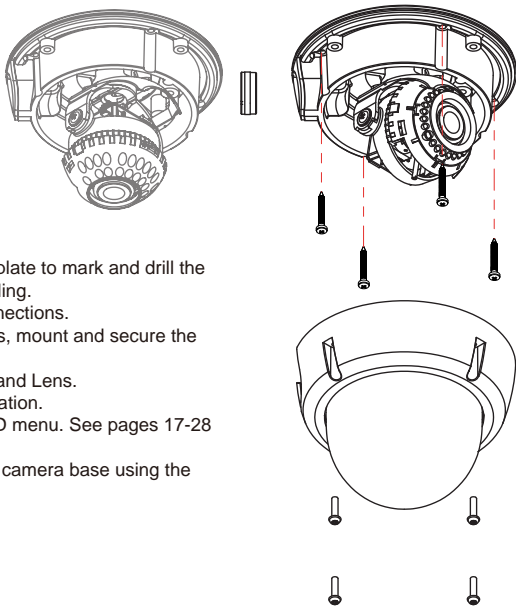

1. Use the camera or mounting template to mark and drill the necessary holes in the wall or ceiling.
2. Pull wires through and make connections.
3. Using the four (4) included screws, mount and secure the camera to the wall or ceiling.
4. Adjust the camera's Pan and Tilt and Lens.  
See pages 15-16 for more information.
5. Use the joystick to adjust the OSD menu. See pages 17-28 for more information.
6. Attach the camera housing to the camera base using the assembly screws.



## JUNCTION BOX INSTALLATION INSTRUCTIONS\*



- 1 Check to see all parts are in the box.



- 2 Use the dry wall anchors and machine screws to mount the junction box and rubber gasket to the wall.



- 3 Insert wires through the wall and make the appropriate connections.



- 4 Attach the camera to the junction box using the machine screws.



- 5 Attach the camera housing to the junction box using the assembly screws.

## WALL MOUNT INSTALLATION INSTRUCTIONS\*



- 1 Check to see all parts are in the box.



- 2 Insert the wires from the camera through the wall mount housing.



- 3 Attach the camera to the wall mount housing.



- 4 Use the mounting template to make pilot holes. Use the dry wall anchors and machine screws to attach the assembly to the wall.



- 5 Attach the camera housing to the fixture.

## PENDANT MOUNT INSTALLATION INSTRUCTIONS\*



**1** Check to see all parts are in the box.



**2** Attach the top shield to the pendant mount.



**3** Slide the wires from the camera through the pendant mount.



**4** Attach the camera to the pendant mount using the machine screws.



**5** Attach the camera housing to the fixture.



**6** Use the mounting template to make pilot holes. Mount the camera assembly to the ceiling using wall mount anchors and machine screws.

## CORNER MOUNT INSTALLATION INSTRUCTIONS\*



❶ Check to see all parts are in the box.



❷ Attach the two compression fittings to the corner bracket.



❸ Attach the wall mount to the corner bracket with the 4 machine screws.



❹ Attach the assembly to a wall corner with dry wall anchors and machine screws.

## CONNECTING TO MONITORS\*

Use the diagram below to connect to a Monitor or CRT Monitor properly.

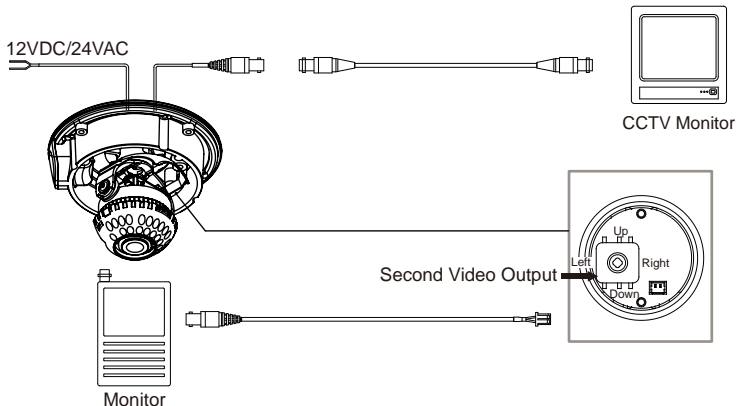

- Power Connection - 12VDC/24VAC Dual Voltage (Auto Polarity Detection and Protection)
- All cameras are equipped with a second video output for on-site configuration.

## CONTROL BOARD\*

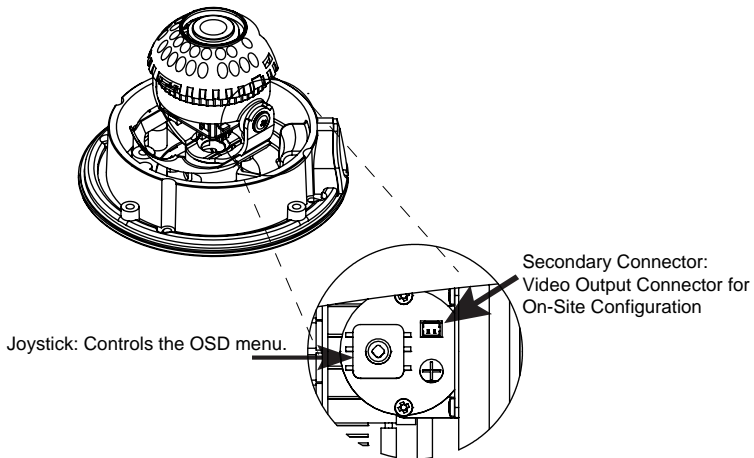

- 1 Remove the camera's cover dome to access the OSD joystick controller.
- 2 Use the joystick to control the camera's OSD options.

## ADJUSTING THE CAMERA LENS\*

Follow the instructions provided below to make any lens adjustments.

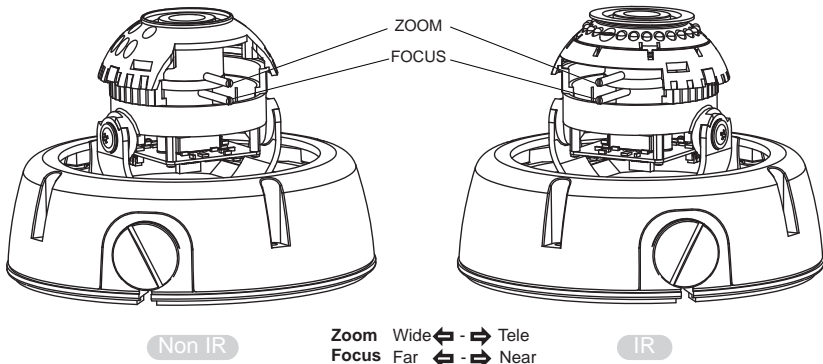

- 1 To adjust the field of view, use the L-Key to turn the zoom screw (located on the bottom of the camera) counter-clockwise to zoom in, or clockwise to zoom out.
- 2 Adjust the focus the same way as described above AFTER the desired zoom position is established.

## ADJUSTING THE CAMERA GIMBAL\*

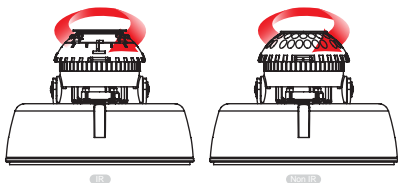

1 Rotation 360°

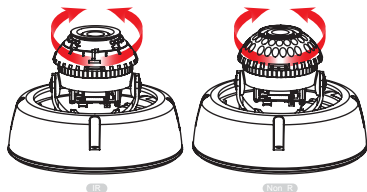

2 Panning 360°

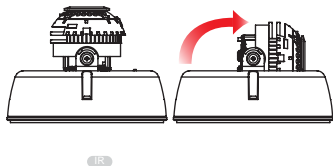

3 Tilting 70° IR LED

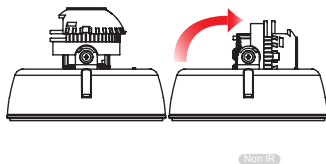

3 Tilting 90°



# MODULE OSD MENU\*

| EXPOSURE  | COLOR   | DAY & NIGHT   | FUNCTION  |
|---|---|---|---|
| <ul style="list-style-type: none"> <li>LENS               <ul style="list-style-type: none"> <li>MANUAL / DC</li> </ul> </li> <li>BACKLIGHT               <ul style="list-style-type: none"> <li>OFF / HME / BLC / WDR</li> </ul> </li> <li>DRC               <ul style="list-style-type: none"> <li>OFF / LOW / MIDDLE / HIGH</li> </ul> </li> <li>DEFOG               <ul style="list-style-type: none"> <li>OFF / ON</li> </ul> </li> <li>AGC               <ul style="list-style-type: none"> <li>0 ~ 20</li> </ul> </li> <li>STARLIGHT               <ul style="list-style-type: none"> <li>OFF / x2 ~ x64</li> </ul> </li> <li>3D DNR               <ul style="list-style-type: none"> <li>OFF / LOW / MID / HIGH</li> </ul> </li> <li>EXIT JUMP               <ul style="list-style-type: none"> <li>SAVE &amp; EXIT / EXIT</li> </ul> </li> </ul> | <ul style="list-style-type: none"> <li>WB BAL.               <ul style="list-style-type: none"> <li>ATW / AWB / PUSH / MANUAL</li> </ul> </li> <li>COLOR GAIN               <ul style="list-style-type: none"> <li>0 ~ 20</li> </ul> </li> <li>EXIT JUMP               <ul style="list-style-type: none"> <li>SAVE &amp; EXIT / EXIT</li> </ul> </li> </ul>   | <ul style="list-style-type: none"> <li>D&amp;N MODE               <ul style="list-style-type: none"> <li>AUTO / COLOR / B&amp;W</li> </ul> </li> <li>CONTROL               <ul style="list-style-type: none"> <li>AUTO / EXIT</li> </ul> </li> <li>EXT LED               <ul style="list-style-type: none"> <li>AUTO / OFF</li> </ul> </li> <li>DELAY               <ul style="list-style-type: none"> <li>LOW / MIDDLE / HIGH</li> </ul> </li> <li>B&amp;W BURST               <ul style="list-style-type: none"> <li>OFF / ON</li> </ul> </li> <li>SMART IR               <ul style="list-style-type: none"> <li>0 ~ 20</li> </ul> </li> <li>EXIT JUMP               <ul style="list-style-type: none"> <li>SAVE &amp; EXIT / EXIT</li> </ul> </li> </ul>             | <ul style="list-style-type: none"> <li>SHARPNESS               <ul style="list-style-type: none"> <li>0 ~ 10</li> </ul> </li> <li>GAMMA               <ul style="list-style-type: none"> <li>0.45 ~ 0.85</li> </ul> </li> <li>MIRROR               <ul style="list-style-type: none"> <li>OFF / ON</li> </ul> </li> <li>FL P               <ul style="list-style-type: none"> <li>OFF / ON</li> </ul> </li> <li>D-ZOOM               <ul style="list-style-type: none"> <li>x1 (0 ~ x8.0)</li> </ul> </li> <li>EXIT JUMP               <ul style="list-style-type: none"> <li>SAVE &amp; EXIT / EXIT</li> </ul> </li> </ul> |
| MOTION  | PRIVACY   | SETUP   | EXIT  |
| <ul style="list-style-type: none"> <li>MOTION               <ul style="list-style-type: none"> <li>OFF / ON</li> </ul> </li> <li>ALARM               <ul style="list-style-type: none"> <li>SHAKING - OFF / ON</li> <li>SHAKE SCALE - 0 ~ 20</li> <li>BRIGHT CHG. - OFF / ON</li> <li>BRIGHT SCL. - 0 ~ 20</li> </ul> </li> <li>QUICK ZOOM               <ul style="list-style-type: none"> <li>OFF / ON</li> </ul> </li> <li>EXIT JUMP               <ul style="list-style-type: none"> <li>SAVE &amp; EXIT / EXIT</li> </ul> </li> </ul>  | <ul style="list-style-type: none"> <li>ZONE NUM.               <ul style="list-style-type: none"> <li>0 ~ 15</li> </ul> </li> <li>ZONE DISP.               <ul style="list-style-type: none"> <li>OFF / ON</li> </ul> </li> <li>H-POS.               <ul style="list-style-type: none"> <li>0 ~ 39</li> </ul> </li> <li>V-POS.               <ul style="list-style-type: none"> <li>0 ~ 30</li> </ul> </li> <li>H-SIZE               <ul style="list-style-type: none"> <li>0 ~ 40</li> </ul> </li> <li>V-SIZE               <ul style="list-style-type: none"> <li>0 ~ 31</li> </ul> </li> <li>Y LEVEL               <ul style="list-style-type: none"> <li>0 ~ 20</li> </ul> </li> <li>CR LEVEL               <ul style="list-style-type: none"> <li>0 ~ 20</li> </ul> </li> <li>CB LEVEL               <ul style="list-style-type: none"> <li>0 ~ 20</li> </ul> </li> <li>EXIT JUMP               <ul style="list-style-type: none"> <li>SAVE &amp; EXIT / EXIT</li> </ul> </li> </ul> | <ul style="list-style-type: none"> <li>COMMUNICA.               <ul style="list-style-type: none"> <li>CAM ID (0 ~ 255)</li> <li>BAUDRATE (2400 / 4800 / 9600 / 57600 / 115200)</li> </ul> </li> <li>V EW ANGLE               <ul style="list-style-type: none"> <li>NORMAL / 4.3 / 16.9</li> </ul> </li> <li>LANGUAGE               <ul style="list-style-type: none"> <li>ENGLISH / CHINESE / CHINESE (S) / JAPANESE / KOREAN</li> </ul> </li> <li>SPECIAL               <ul style="list-style-type: none"> <li>DEFECT DET. / TV MODE / O.L.P.F</li> </ul> </li> <li>NITIAL               <ul style="list-style-type: none"> <li>ON</li> </ul> </li> <li>EXIT JUMP               <ul style="list-style-type: none"> <li>SAVE &amp; EXIT / EXIT</li> </ul> </li> </ul> | <ul style="list-style-type: none"> <li>SAVE &amp; EXIT</li> <li>EXIT</li> </ul>   |



## EXPOSURE



### LENS

Manual

Manual mode supports the fixed board lens or the manual iris lens.

DC

DC mode supports the auto-iris varifocal lens.

NOTE: Both MANUAL and DC mode have FOCUS ADJ. You can adjust the focus by finding the highest number on the FOCUS SET.

### DC Lens Submenu

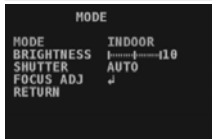

### MANUAL Lens Submenu

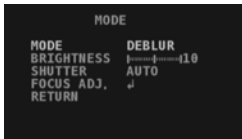

Mode: MANUAL: Set the lens mode to Normal or Deblur.

DC: Set the lens mode to Outdoor, Indoor, or Deblur.

Brightness: Adjust the camera's brightness from 0~20. The higher the number, the brighter the image will appear.

Shutter: Set the shutter speed to AUTO, Manual, or FLC (Flicker-less mode).

Select FLC if the camera is experiencing some flickering in the image. If selected, the shutter speed will automatically be set to 1/100 for NTSC, or 1/120 for PAL.

If Manual is selected, set the shutter speed from 1/60 to 1/60000.

Focus Adjustment: When on, the default level is set automatically by controlling lens focus and based on the installation and environment circumstances.



## EXPOSURE

### BACKLIGHT

OFF

HME

### HIGHLIGHT MASKING EXPOSURE

HME allows objects to appear clearly on the screen by masking extremely bright areas. To setup HME, set the level and mode. The lower the setting, the darker the masking areas have to be. Select from: 0 ~ 20.

Mode: Select when to enable HME settings. Select from All Day (Run HME always), or Night Only (HME is enabled only in B/W mode).



### BLC BACK LIGHT COMPENSATION

If BLC is selected, adjust the size and position of the mask:

- H-POS: Move the Zone position left or right. The higher the number, the zone will move to the right.
- V-POS: Move the Zone position up or down. The higher the number, the zone will move down.
- H-Size: Reset the zone's size horizontally. The higher the number, the right side panel will move further to the right.
- V-Size: Reset the zone's size vertically. The higher the number, the bottom side panel will move further down.

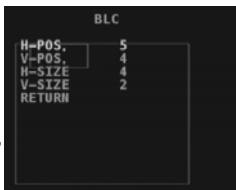

### WDR Wide Dynamic Range

If WDR is selected, adjust the WDR level in the submenu. Select from Low, Middle, or High (Default).



## EXPOSURE

### DRC DYNAMIC RANGE COMPRESSOR

DRC enables dark areas in images to become more visible without overexposing the bright areas to create one perfect image. Select from: Off, Low, Middle, or High

NOTE: If WDR or DEFOG are enabled, the DRC settings are set automatically and will not be available for adjustment.

**DEFOG** Allows the camera to process a scene that is obscured by fog or weather conditions and provides a visibly improved image.

AUTO / Manual: Select AUTO to have the WDR and DRC levels adjusted automatically. Set the DEFOG level from LOW / MIDDLE / HIGH.

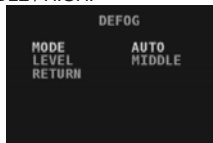

### AGC AUTO GAIN CONTROL

0~20  
AGC enhances the picture brightness in low light conditions. A higher level AGC setting makes the images brighter; however, it could increase the amount of noise.

### STARLIGHT

OFF / x2 ~ x64  
(Default: X4)

Automatically activates slow shutter function when the image is too dark. High values are not recommended as they may cause the image to lag. Starlight menu cannot be controlled if the SHUTTER setting is above 1/60.

### 3D DNR

OFF / LOW /  
MID / HIGH

### 3D DIGITAL NOISE REDUCTION

3D-DNR reduces the noise on the screen in low light conditions and allows for clearer images, even at night.



## COLOR

### WB MODE

**ATW** Auto Tracking White Balance Control mode compensates for color temperature changes between 2400K° and 11000K°.

**AWB** Auto White Balance Control mode compensates for color temperature changes lower than 2000K° and higher than 15000K°.

**PUSH** Push fixes the white balance based on the current lighting automatically.

**MANUAL** Users can control the white balance manually by changing RED GAIN and BLUE GAIN (see below).

**KELVIN:** Select from Low, Middle, or High. If enabled, the Red and Blue Gain settings will be set automatically according to the Kelvin settings.

**RED GAIN:** 0 ~ 20. Adjusts the amount of red in the image.

**BLUE GAIN:** 0 ~ 20. Adjusts the amount of blue in the image.



### COLOR GAIN

Set the color gain from 0~20.



## DAY & NIGHT

### D&N MODE

**AUTO** / In AUTO mode, the camera switches between day and night automatically depending on light level. If COLOR is selected, the camera always stays in day/color mode.  
**B&W** / If B&W is selected, camera always stays in night/B&W mode.

### CONTROL

Select if the Day/ Night switch will be based on the AGC levels (AUTO), or using IR LED lights (EXT.)

**AUTO:** if selected, Day/ Night switch will depend on the AGC levels.

- AGC Threshold: Set when the camera switches between Day & Night.
- AGC Margin: Set the value added to the AGC Threshold. Adjust the value based on the environment in which the camera is installed.
- Night Mode: Select what will the camera do when light threshold is met for "Night Mode". Select to keep in color, or switch to B&W.
- At the bottom of the screen, the settings will be summarized for your review. The information includes (according to current settings), the AGC threshold for Day to switch to Night, AGC threshold for Night to switch back to Day, and current AGC level, for reference.

**EXT.:** if selected, adjust the external signal to CDS or LOW/HIGH.

- Low/ High: The camera's Day/ Night switch will be set according to an external LED board. Set to HIGH to make the camera switch to night mode only when there is very little light.
- Night Mode: Select what will the camera do when light threshold is met for "Night Mode". Select to keep in color, or switch to B&W.
- At the bottom of the screen, the settings will be summarized for your review. The information includes (according to current settings), the EXT level for Day to switch to Night, EXT level for Night to switch back to Day, and current EXT level, for reference.





## DAY & NIGHT

### CONTROL (CONT.)

- CDS: The camera's Day/ Night switch will be set according to the LED board in the camera.
  - \* CDS Threshold: Marks the light level at which the camera will switch between color and B/W. The lower the value, the camera will require less light (more darkness) to switch to Night Mode.
  - \* CDS Signal: The value added to the CDS Threshold. Adjust this value based on the environment in which the camera is installed.
- Night Mode: Select what will the camera do when the light threshold is met for "Night Model". Select to keep in color, or switch to B&W.
- At the bottom of the screen, the settings will be summarized for your review. The information includes (according to current settings), the CDS threshold for Day to switch to Night, CDS threshold for Night to switch back to Day, and current CDS level, for reference.

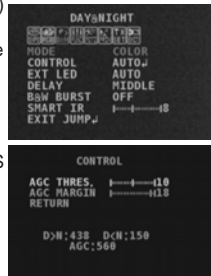

### EXT LED

AUTO / OFF AUTO: Enables the IR LED board. OFF: disable the camera's LEDs.

### DELAY

Low/Mid/High Time interval delay before switching from day mode to night mode.

### B&W BURST

ON / OFF If ON is selected, the camera provides a color burst signal in night mode.

### SMART IR

0 ~ 20 Enable Smart IR and set the level. Higher values will make Smart IR stronger.



## FUNCTION

### SHARPNESS

0 ~ 10 Sets the image sharpness. The higher the number, the sharper the image.

### GAMMA

0.45 ~ 0.65 Select the desired gamma level. 0.55 is default setting.

### MIRROR / FLIP

OFF

MIRROR Reflects the camera horizontally.

FLIP Reflects the camera vertically.

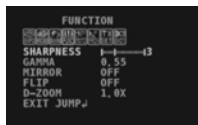

Mirror / Flip OFF



Mirror ON



Flip ON



Mirror & Flip ON

### D-Zoom

1.0x ~ 8.0x Enable or Disable Digital zoom to the camera's field of view. By default, the zoom will go to the center of the camera's Field of View.





## MOTION

The camera can detect the movement and display an alarm on the screen when movement is detected.

### MOTION

**OFF/ON** Select to enable or disable the camera's motion detection. If ON is selected:

### DET. SETTINGS

Use this submenu to adjust the motion detection's sensitivity, detection dwell time, Motion Estimate, and setup a Signal Output Action:

- Sensitivity: The smaller the movement you want to detect, the higher the sensitivity value must be.
- Object Keep LV: Set the dwell time for how long motion is detected.
- Motion Estimate: Predicts possible direction once motion is disappeared by wall or curtain. The lower the number, the more sensitive the camera will be to new motion once detected.
- Signal Out: If Alarm is enabled, when motion is detected, the camera can support 3.3V power output to an external signal.



### MOTION SET

- Window Tone: Set the size of the zone's borders.
- Window Zone: The camera supports up to 4 different motion detection zones.
- Window Use: Select which one of the motion areas to enable.
- DET H-POS: Move the Zone left or right. The higher the number, the zone will move to the right.
- DET V-POS: Move the Zone up or down. The higher the number, the zone will move down.
- DET H-Size: Adjust the zone's size horizontally. The higher the number, the right side panel will move further to the right.
- DET V-Size: Reset the zone's size vertically. The higher the number, the bottom side panel will move further down.



## MOTION

The camera can detect the movement and display an alarm on the screen when movement is detected.

### ALARM

Select to enable or disable the camera's motion detection, and select which conditions will trigger the alarm from the following options:

- Shaking (ON / OFF): "Camera Moving!!" will appear if the camera is shaken abruptly.
- Shaking Scale (0 ~ 20): The lower the number, the more sensitive the camera will be to shocks or vibrations.
- Bright Change (ON / OFF): "Bright Change!!" will appear if the brightness in the scene changes suddenly and drastically.
- Bright Scale (0 ~20): The lower the number, the more sensitive the camera is to brightness changes in the scene.



### QUICK ZOOM

The camera can automatically digitally zoom in when motion is detected.

In the submenu, setup the following:

- MOVING: Set the camera's movement speed. 30/60 (0.5 Second) is the default speed. Max speed: 240/60 (4 Seconds).
- ZOOM IN: Set the camera's zooming speed. 30/60 (0.5 Second) is the default speed. Max speed: 240/60 (4 Seconds).
- STAND BY: Setup the dwell time for the camera to remain zoomed in. 30/60 (0.5 Second) is the default speed. Max speed: 240/60 (4 Seconds).
- SYNCHRONOUS: Set by default. Should not be changed.
- TRACKING: The camera keeps tracking the moving area and operates Zoom In/Out
- REPEAT: The camera will continue to zoom into motion as it detects it in different parts of the camera's view.





## PRIVACY

You can hide some parts of the screen for privacy masking. A total of 8 different privacy masking zones are available.

### PRIVACY SET

- Select the zone number you want to setup.
- To enable it, turn the display option ON.
- H-POS: Move the Zone position Left or right. The higher the number, the zone will move to the right.
- V-POS: Move the Zone position up or down. The higher the number, the zone will move down.
- H-Size: Reset the zone's size horizontally. The higher the number, the right side panel will move further to the right.
- V-Size: Reset the zone's size vertically. The higher the number, the bottom side panel will move further down.



### MASK COLOR

To adjust the mask's color, use the Y, CR, and CB Levels:

- Y Level- The higher the number, the brighter the color will appear.
- CR Level- The higher the number, the more red tone will be added to the zone's color.
- CB Level- The lower the number, the more green will be added to the zone's color.
- CB Level- High CB Level + High CR Level = Red
- High CB Level + Low CR Level = Blue
- Low CB Level + High CR Level = Orange



## SETUP

### COMMUNICATION

Use this setup menu to adjust the camera's ID and Baudrate.

The camera's default Protocol is Pelco-D.

- CAM ID: Provide an ID number for the camera ( 0 ~ 255 ).
- BAUDRATE: 9600bps is default. Select the baudrate from the following options: 2400/4800/9600/57600/115200 bps.

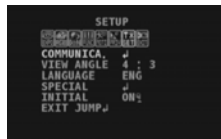

### VIEW ANGLE

4:3 / 16:9 / Adjust the camera's aspect ratio. By default, the camera is set to NORMAL 4:3. If applicable, set it to 16:9.

### LANGUAGE

The Camera supports the following languages: English (Default), Chinese, Chinese (S), Japanese, and Koran.

### SPECIAL

DEFECT DET.: The camera can detect and correct dead pixels in the image. To do so, press the select button and set the threshold level.

The camera will detect and adjust the pixels automatically.

TV MODE: Set the camera to NTSC (Default) or PAL.

OLPF: Select the filter that you use from RED and PASS, then reboot the camera to use.

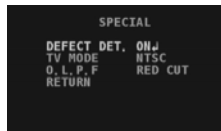

### INITIAL

Reset the camera to its factory default settings. To do so, press and hold the select button for five (5) seconds.



## EXIT

EXIT

SAVE Exit the OSD menu after saving the recent changes.

INITIAL Exit the OSD menu after resetting the camera to factory default.



## **TROUBLESHOOTING**

---

Before sending your camera for repair, check the following or contact our technical specialist.

### **FOR NO VIDEO**

Check the coaxial cable and make sure it is connected securely.

Check the lens' iris adjustment at the camera's OSD menu.

Check the power supply and make sure the camera has the proper voltage and current.

### **FOR OUT-OF-FOCUS VIDEO**

Check the clear dome cover and the lens for dirt or fingerprints. Use a soft cloth and gently clean. Check the lens' manual focal and zoom adjustment. The use of a field test monitor is recommended.



## WARRANTY INFORMATION\*

Digital Watchdog (referred to as “the Warrantor”) warrants the Digital Watchdog Camera against defects in materials or workmanship as follows:

**LABOR:** For the initial five (5) years and one (1) year on IR LED from the original purchase date, if the camera is determined to be defective, the Warrantor will repair or replace the unit with a new or refurbished product at its option at no charge.

**PARTS:** In addition, the Warrantor will supply replacement parts for the initial five (5) years and one (1) year on IR LED.

To obtain warranty or out of warranty service, please contact a Technical Support Representative at **1-866-446-3595** Monday through Friday from 9:00AM to 8:00PM Eastern Standard Time.

A purchase receipt or other proof of the original purchase date is required before warranty service is rendered. This warranty only covers failures due to defects in materials and workmanship which arise during normal use. This warranty does not cover damage which occurs in shipment or failures which are caused by products not supplied by the Warrantor or failures which result from accident, misuse, abuse, neglect, mishandling, misapplication, alteration, modification, faulty installation, set-up adjustments, improper antenna, inadequate signal pickup, maladjustment of consumer controls, improper operation, power line surge, improper voltage supply, lightning damage, rental use of the product or service by anyone other than an authorized repair facility or damage that is attributable to acts of God.

## LIMITS & EXCLUSIONS\*

There are no express warranties except as listed. The warrantor will not be liable for incidental or consequential damages (including damage to recording media without limitation) resulting from the use of these products or arising out of any breach of the warranty. All express and implied warranties, including the warranties of merchantability and fitness for particular purpose, are limited to the applicable warranty period set forth above.

Some states do not allow the exclusion or limitation of incidental or consequential damages, or limitations on how long an implied warranty lasts, so the exclusions or limitations listed above may not apply to you. This warranty gives you specific legal rights, and you may also have other rights that vary from state-to-state.

If the problem is not handled to your satisfaction, then write to the following address:

Digital Watchdog, Inc.  
ATTN: RMA Department  
5436 W. Crenshaw Street  
Tampa, FL 33634

Service calls which do not involve defective materials or workmanship as determined by the Warrantor, in its sole discretion, are not covered. Costs of such service calls are the responsibility of the purchaser.



## SPECIFICATIONS\*

| VIDEO                 |  |
|-----------------------|--|
| Image Sensor          | 1/3" Sony 1.3 Mega Pixel CMOS Sensor     |
| Active Pixels         | 1280 (H) x 1024 (V)                      |
| Scanning System       | 2 : 1 Interlace                          |
| Frequency             | 15.734KHz (H), 59 95Hz (V)               |
| Synchronization       | Internal                                 |
| Horizontal Resolution | 820 TV Lines [B/W], 800 TV Lines [Color] |
| Minimum Illumination  | F1.2 (30IRE): 0.0 Lux                    |
| S/N Ratio             | 55dB (AGC off)                           |
| Video Output          | CVBS: 1.0Vp-p / 75 $\Omega$              |
| Alarm Output          | 1 Alarm Output                           |
| LENS                  |  |
| Focal Length          | 2.8~12 mm                                |
| Lens Type             | Varifocal Auto Iris Lens                 |
| IR Distance           | 100ft Range IR [DWC-V5661TIR Only]       |
| OPERATIONAL           |  |
| Shutter Speed         | 50(60) ~ 60,000s                         |
| Backlight             | OFF / HME / BLC / WDR                    |
| Star-Light (Sense-Up) | OFF / x2 ~ x64                           |
| 3D-DNR                | OFF / Low / Middle / High                |
| White Balance         | ATW /AWB/ PUSH / MANUAL                  |
| Day and Night         | Auto / Day / Night                       |

## SPECIFICATIONS\*

| OPERATIONAL                   |  |
|-------------------------------|--|
| Auto Gain Control             | 0 ~ 20   |
| Intelligent Motion Detection  | Digital Quick Zoom   |
| Motion Detection              | 4 Motion Regions   |
| Privacy Zones                 | 16 Programmable Privacy Masks                              |
| Enhanced Day & Night Function | LED Operation point selection, External LED ON/OFF Control |
| Sharpness                     | 0 ~ 10   |
| Gamma                         | 0.45 ~ 0.65  |
| De-Fog                        | OFF/ ON  |
| ENVIRONMENTAL                 |  |
| Operating Temperature         | -20°C ~ 60°C (-4°F ~ 140°F)                                |
| Operating Humidity            | Less than 90% (Non-Condensing)                             |
| IP Rating                     | IP66 (Protects against dust and high pressure water.)      |
| ELECTRICAL                    |  |
| Power Requirement             | Dual Voltage (DC12V, 24VAC)                                |
| Power Consumption             | DC12V: 3.3W, 275mA, LED On: 5.94W, 495mA                   |
|                               | AC24V: 2.56W, 106mA, LED On: 4.9W, 204 mA                  |
| MECHANICAL                    |  |
| Housing Material              | Aluminum   |
| Dimensions                    | 145 x 108.8 mm (5.7 X 4.28 in)                             |
| Weight                        | 1.65 lbs   |

\*Specification is subject to change without prior notice.

**MEMO\***

A large, empty rounded rectangle with a thin grey border, occupying most of the page area below the 'MEMO\*' label. It is intended for handwritten notes.



*Everything's Digital*

5436 W Crenshaw St. Tampa, FL 33634  
Tel : 866-446-3595 / 813-888-9555  
Fax : 813-888-9262  
[www.Digital-Watchdog.com](http://www.Digital-Watchdog.com)  
[technicalsupport@dwcc.tv](mailto:technicalsupport@dwcc.tv)  
Technical Support Hours : Monday-Friday  
9:00am to 8:00pm EST