

Installation Manual

Replacement Convenience Open Board For Pre-2016 Convenience Open Operators ONLY

Use this manual for circuit board 1473-010.

1473-065-€-2-18

For **Pre-2016** Convenience Open Models:
1600, 1602, 1603, 6100, 6300, 6500, 9150 and 9310 Operators **ONLY**

Replacement Board for
2340-010 Convenience Open Board

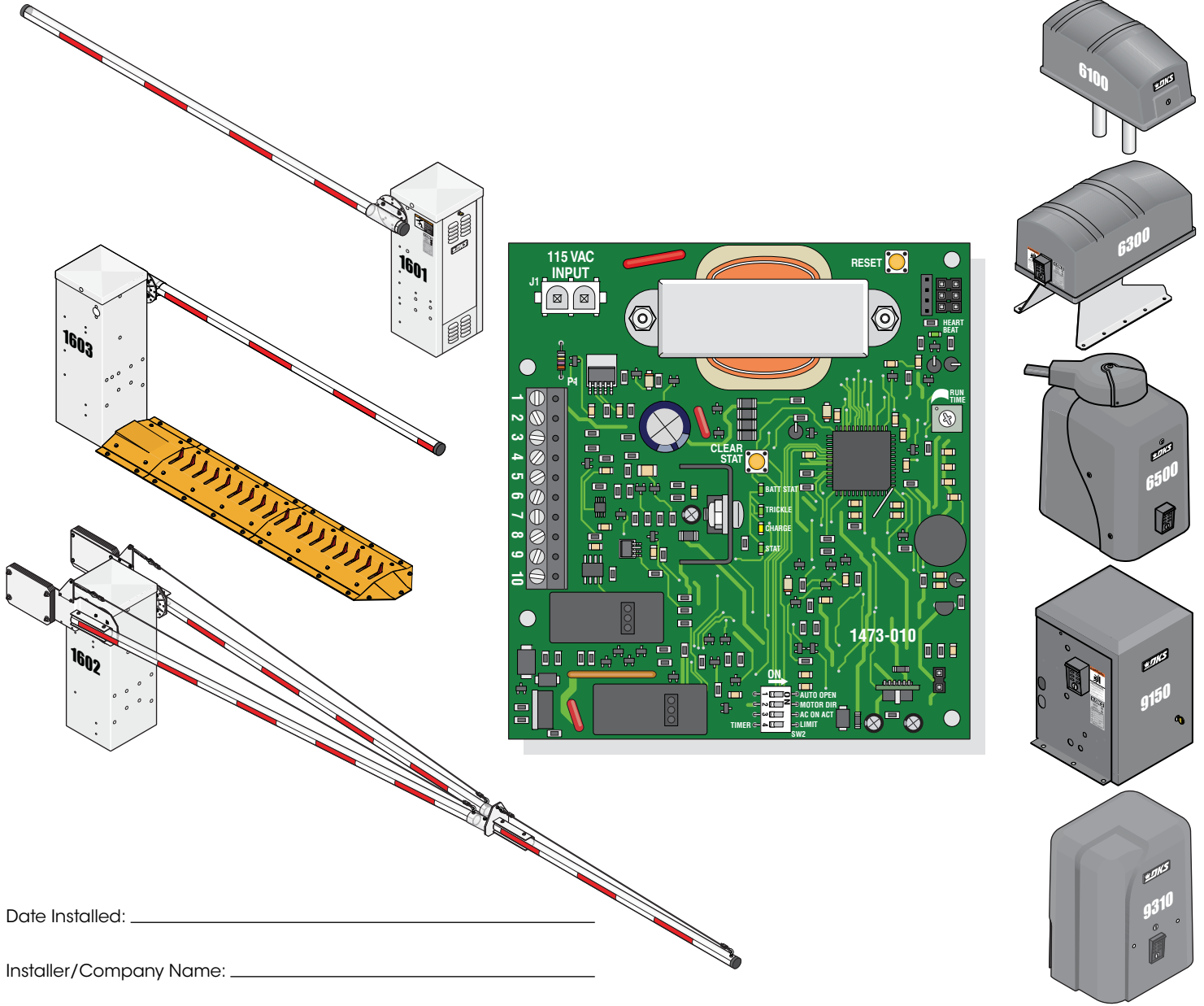

Date Installed: _____

Installer/Company Name: _____

Phone Number: _____

Operator Circuit Board
Serial Number
and Revision Letter: _____

Leave Manual with Owner

Copyright 2018 DoorKing, Inc. All rights reserved.



TABLE OF CONTENTS

1473 CONVENIENCE OPEN BOARD INTRODUCTION 2

1473 Board Overview	2
DIP-Switches	3

SPECIFIC GATE OPERATOR INSTALLATION 4

6100, 6300 Swing Gate Operator(s)	4-5
6500 Swing Gate Operator(s)	6-7
9150 Slide Gate Operator(s)	8-9
9310 Slide Gate Operator(s)	10-11
1601, 1602, 1603 Barrier Gate Operator(s)	12-13
Replacement Parts for Convenience Open System	14

DoorKing, Inc. reserves the right to make changes in the products described in this manual without notice and without obligation of DoorKing, Inc. to notify any persons of any such revisions or changes. Additionally, DoorKing, Inc. makes no representations or warranties with respect to this manual. This manual is copyrighted, all rights reserved. No portion of this manual may be copied, reproduced, translated, or reduced to any electronic medium without prior written consent from DoorKing, Inc.

1473 CONVENIENCE OPEN BOARD INTRODUCTION

Use this manual when replacing a 2340-010 convenience open board on an existing **PRE-2106** gate/barrier operator **ONLY**.

The 2340-010 control board is obsolete and cannot be replaced.

IMPORTANT

- The 1473 convenience open board is a **REPLACEMENT board** for an **existing** 2340 convenience open board **ONLY**.
- The convenience open system **cannot** provide continuous gate operation during a power outage.
- Operation of this system is limited to cycling the gate to the open (up) position **ONE TIME ONLY**.
- The convenience open system requires testing on a monthly basis to insure the batteries are fully charged and that the system is operational.
- The convenience open system uses two 12-volt, 3.0 amp-hour gel-cell batteries. These batteries should be replaced every two years on average, or sooner if required. A reminder beeper has been designed in the 1473 board, see below.
- Batteries are affected by temperature. Cold temperatures will reduce the effectiveness of the batteries and the backup system. High temperatures will result in a shortened battery life.
- Batteries are not covered under warranty.
- This system **cannot** be used with **SLIDE** gate operators that are configured in the **Fail-SECURE mode**.
- If your access control system requires 100% power backup and **continuous operation** when primary (AC) power has failed, a power inverter / backup system, such as DoorKing's Model 1000 can be purchased separately.

1473 Board Overview

115 VAC Input (J1)

Connect to gate operator's terminal inputs as shown on following pages, **REQUIRED**. **DO NOT** connect to 208/230 VAC input.

10-Pin Terminal (P4)

COMMON-1

Common for open, radio receiver or open limit switch. **Note:** Radio receiver cannot be connected when the 1473 is installed in a 1601, 1602, 1603, 6500 or 9310 gate operator.

OPEN INPUT (LIMIT)-2

Open input. (Open limit switch for 1601, 1602, 1603, 6500, 9310).

RADIO POWER-3

24 -Volt power for radio receiver (9150 and 6100/6300 gate operators **only**). Radio gets powered by operator batteries during power outage.

ACTIVATION OUTPUT-4

Radio relay activation or switch closure across terminals 1 and 2 will send an activation signal out of this terminal to the gate operator single-button activation input.

24 VAC INPUT-5-Not Used

24 VAC COMMON-6

BATTERY POSITIVE INPUT-7

BATTERY NEGATIVE INPUT-8

DC MOTOR POSITIVE OUTPUT-9

DC MOTOR NEGATIVE OUTPUT-10

Note: See pages 4-13 for **your specific** gate operator(s) terminal connection.

Reset Button

Press to reset board.

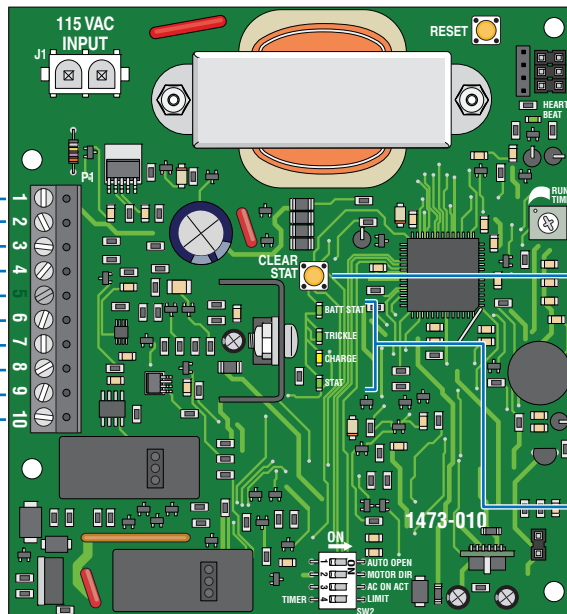

1473 DIP-Switches

See next page.

HEART BEAT LED

Blinking: Indicates board is operating normally.

Run Timer Adjustment

DIP-Switch 4 **MUST** be **OFF** to adjust 4-41 sec. Clockwise increases the run time, Counter-clockwise decreases the run time. See next page.

Clear Stat Button

Press and hold the **CLEAR STAT** button for 4 secs clears the battery replacement reminder counter and resets the beeping indication.

Beeper

A beep every 20 seconds indicates that battery replacement is needed. Press and hold the **CLEAR STAT** button to reset the battery reminder beeping and clear the counter.

Battery LEDs

BATT STAT LED

- 2 Blinks:** Replace batteries.
- 3 Blinks:** Battery level is too low.
- 4 Blinks:** Batteries are not connected.
- 5 Blinks:** Bad battery.
- 6 Blinks:** Battery charge current exceeds maximum, possible shorted cell.

TRICKLE LED

Steady Green LED: Battery is fully charged and a trickle charge is being used to maintain a full charge.

CHARGE LED

Steady Yellow LED: Battery is being bulk charged.
Blinking Yellow LED: Battery is 90% of a full charge.

STAT LED

3 Blinks: Extreme temperature, charging suspended.

1473 DIP-Switches

Switch	Function	Setting	Description
1	Auto Open Operation After Power Outage	OFF	(Manual Mode) Residential application: For 6100/6300 or 9150 operators ONLY . Gate will remain closed after a power outage. A radio receiver input or switch closure device across terminals 1 and 2 will run the operator motor's "Run Time" set on the 1473 to the open position. (1601, 1602, 1603, 6500 or 9310 models will NOT function in this mode).
		ON	(Auto Mode) Apartment complexes, gated communities, etc.: Gate will automatically run the operator motor's "Run Time" set on the 1473 OR use the operator's limits to the open position. This switch MUST be ON for 1601, 1602, 1603, 6500 and 9310 operators.
2	Motor Dir Motor Direction	OFF	Sets the opening direction (up) of the gate. If the gate won't open after a power outage, reverse this switch.
		ON	
3	AC on ACT Restore Power Operation	OFF	Physical Input Required: An input (push button, loop, radio receiver, etc.) is required to return the gate to normal operation again.
		ON	Auto: a 1-second pulse is automatically sent to the gate operator input to restore normal operation again.
4	Timer-OFF Limit-ON Operator Type	Timer-OFF	1473 "run timer" is used and MUST be adjusted. For 9150 OR 6100/6300 gate operators ONLY .
		Limit-ON	Operator limits are used to stop gate at open/up position. For 1601, 1602, 1603, 6500 and 9310 operators ONLY .

Switch 1 OFF: Manual Mode - Residential ONLY

Manual mode is designed for **residential applications only, for 6100/6300 or 9150 operators ONLY**. (1601, 1602, 1603, 6500 or 9310 models will **NOT** function in this mode).

DIP-Switch 1 **OFF:** the 1473 will not open the gate if a power failure occurs until a **manual input** is received, either from a wired push button or RF transmitter. This allows the gate to **remain closed** upon a loss of AC power, but provides a method to open the gate when desired. In manual mode, the **STAND-ALONE RF receiver** is connected **directly to the 1473 control board** and is powered by this board. During normal daily operation, when the relay in the radio receiver closes (a valid transmitter code has been received), this "signal" is passed through the 1473 control board's **terminal 4** that has been wired to the gate operator's main control board terminal **open input**. If a power failure occurs, the radio receiver is powered from the operator batteries maintaining its operation. When a valid RF transmitter code is received under these conditions, the 1473 control board signals the operator DC motor to **run for the set "Run Time"**. A push button device wired to terminals 1 and 2 on the 1473 control board will also open the gate after a power outage has occurred.

Note: The RF transmitter will open the gate when using a **stand-alone type receiver**. If the gate system uses a receiver that **outputs the transmitter code** in weigand format to a **phone entry system** (such as DoorKing's 1833, 1835, 1837 or 1838), then opening the gate from the RF transmitter under power outage conditions will **NOT** be possible when the system has been set up this way.

Switch 1 ON: Auto Mode - Apartment Complexes, Gated Communities, Etc.

DIP-Switch 1 **ON:** the 1473 will **automatically** open the gate or raise the barrier arm approximately 2-3 seconds **AFTER** loss of AC power occurs. Automatic mode is **always used** for gates in general access applications such as gated communities, apartment complexes, etc. Automatic mode **MUST** be used with 1601, 1602, 1603, 6500 and 9310 operators.

Switch 2: Operator Opening Direction

The operator **MUST** open (Barrier arm goes UP) when power outage occurs. If the operator doesn't open during a power outage, reverse this switch's position.

Switch 3: Restarting Operator AFTER AC Power Has Been Restored

DIP-Switch 3 **ON:** **Automatically "Re-keys"** the gate operator to establish normal operation again.

DIP-Switch 3 **OFF:** **Requires a "physical input"** (push button, loop, radio receiver, etc.) **BEFORE** the gate operator will resume normal operation again.

Switch 4: Using 1473 "Run Timer" or Operator's Limits for Open Position

DIP-Switch 4 **ON:** Uses the gate operator **LIMITS** to stop the gate/arm at the open position. For 1601, 1602, 1603, 6500 and 9310 operators **ONLY**. Not for use on 6100/6300 or 9150 operators.

DIP-Switch 4 **OFF:** Uses the 1473 **RUN TIMER** setting (4 to 41 secs) to stop the gate at the open position. For **6100/6300** or **9150** operators **ONLY**. Not for use on 1601, 1602, 1603, 6500 and 9310 operators.

1473 "Run Timer" Description



Used for **6100/6300** or **9150** gate operators **ONLY**. The "run timer" sets the amount of time that the operator's DC motor will run after it gets activated by the 1473 circuit board. Adjust the run timer so that the gate opens to approximately six inches shy of the full open position and stops. **DO NOT** allow the DC motor to run beyond the full open position and slip the operator clutch or stall the DC motor. Damage to the circuit board may result from this. Clockwise adjustment increases the run time, counter-clockwise adjustment decreases the run time.

Note: The run timer is **not used** when the 1473 circuit board is installed in the 1601, 1602, 1603, 6500 or 9310 operators.

SPECIFIC GATE OPERATOR INSTALLATION

Select **YOUR** specific gate operator(s) installation on this page or the following pages.

6100, 6300 Single Swing Gate Operator

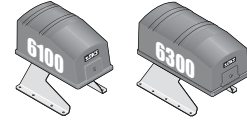

Single Operator Control Board

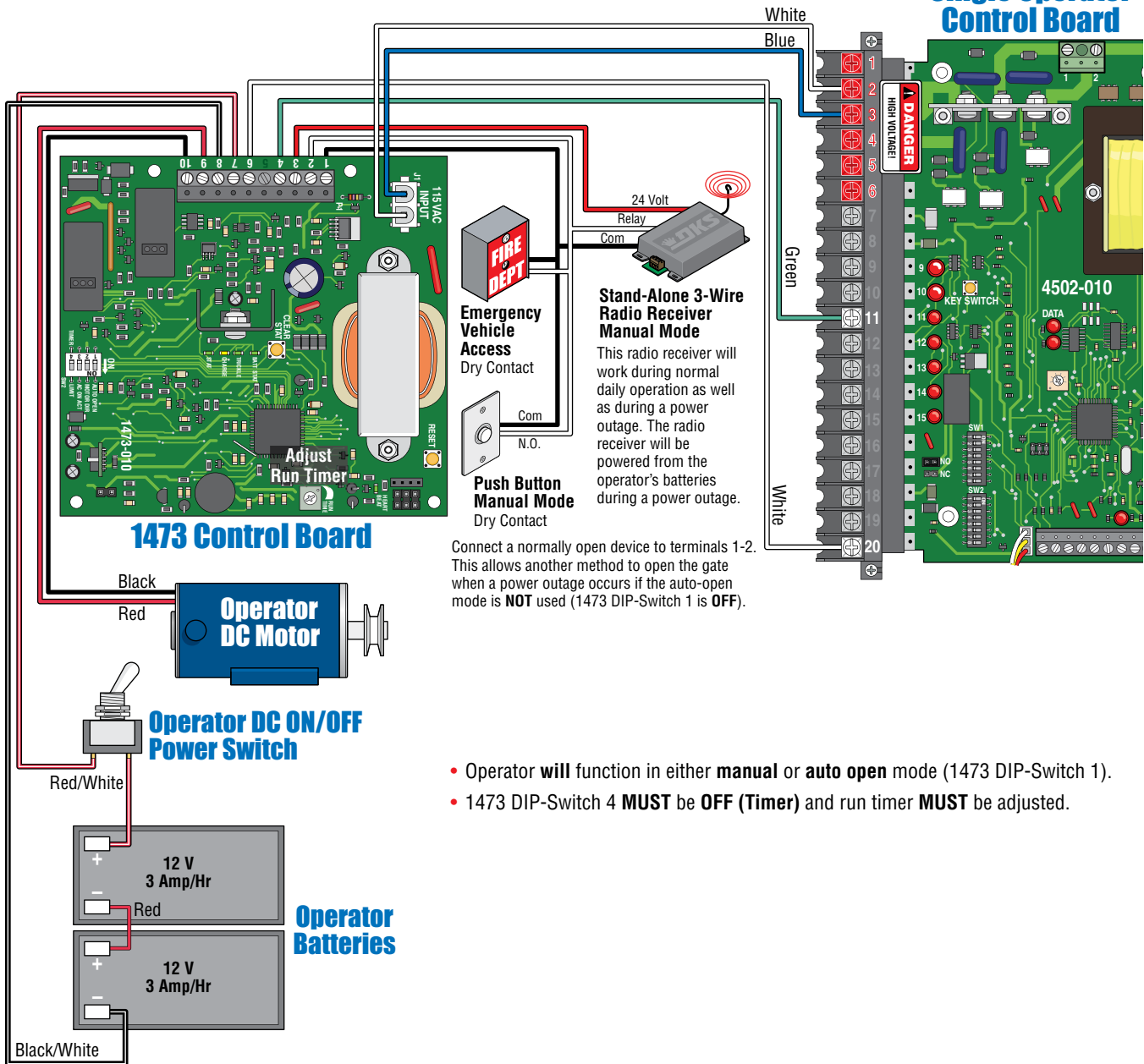

- Operator **will** function in either **manual** or **auto open** mode (1473 DIP-Switch 1).
- 1473 DIP-Switch 4 **MUST** be **OFF (Timer)** and run timer **MUST** be adjusted.

6100, 6300 Bi-Parting Swing Gate Operators

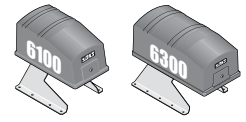

Connect a normally open device to terminals 1-2 of the **PRIMARY** 1473 **ONLY**. This allows another method to open the gate when a power outage occurs if the auto-open mode is **NOT** used (1473 DIP-Switch 1 is **OFF**).

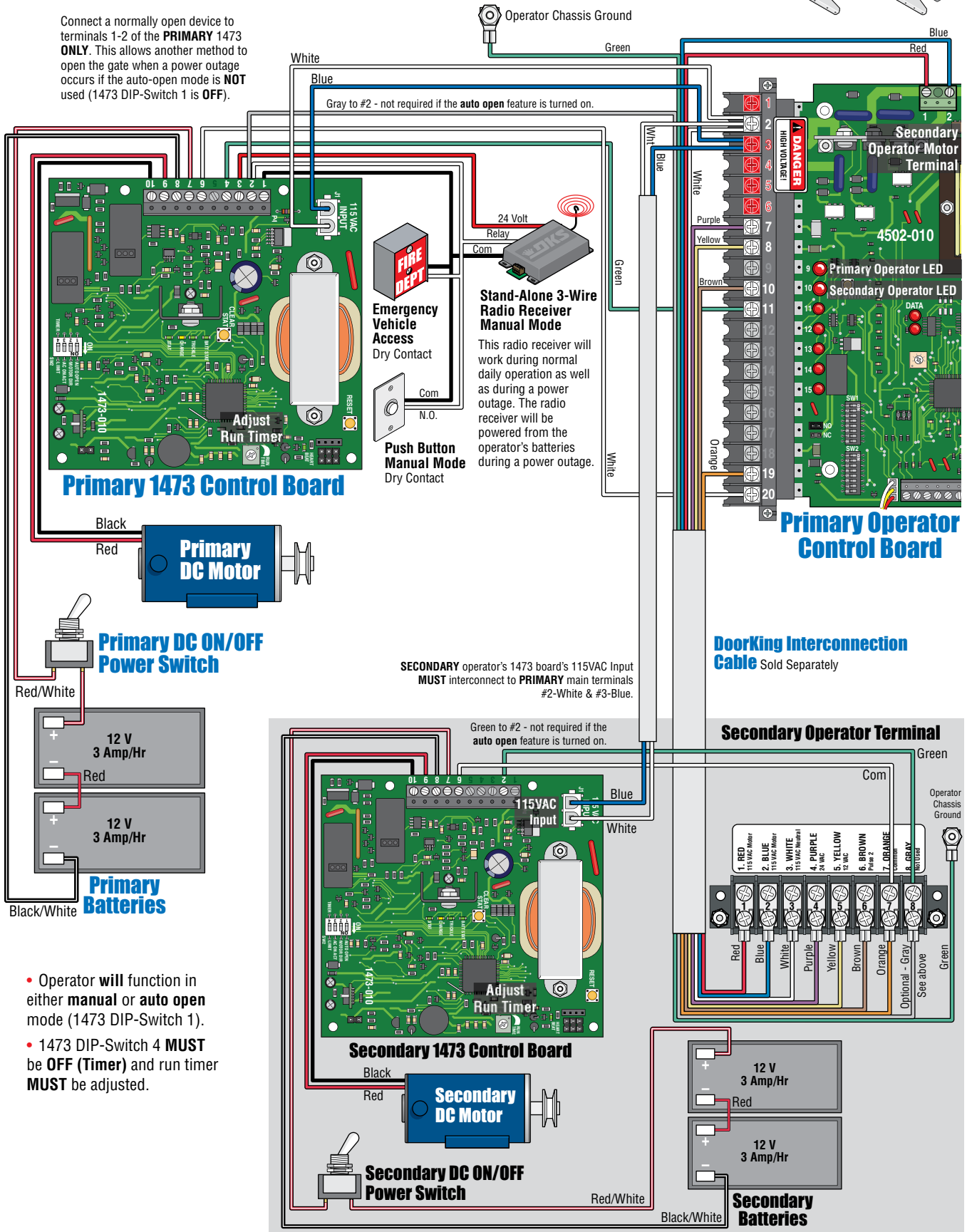

Operator Chassis Ground

Gray to #2 - not required if the auto open feature is turned on.

Stand-Alone 3-Wire Radio Receiver Manual Mode

This radio receiver will work during normal daily operation as well as during a power outage. The radio receiver will be powered from the operator's batteries during a power outage.

Emergency Vehicle Access Dry Contact

Push Button Manual Mode Dry Contact

SECONDARY operator's 1473 board's 115VAC Input **MUST** interconnect to **PRIMARY** main terminals #2-White & #3-Blue.

Green to #2 - not required if the auto open feature is turned on.

- Operator **will** function in either **manual** or **auto open** mode (1473 DIP-Switch 1).
- 1473 DIP-Switch 4 **MUST** be **OFF** (Timer) and run timer **MUST** be adjusted.

6500 Single Swing Gate Operator



- Operator will **ONLY** function in **auto open** mode (1473 DIP-Switch 1 **ON**).
- 1473 DIP-Switch 4 **MUST** be **ON (Limit)**. This allows the 1473 to use the 6500's magnetic limit for the gate OPEN position.

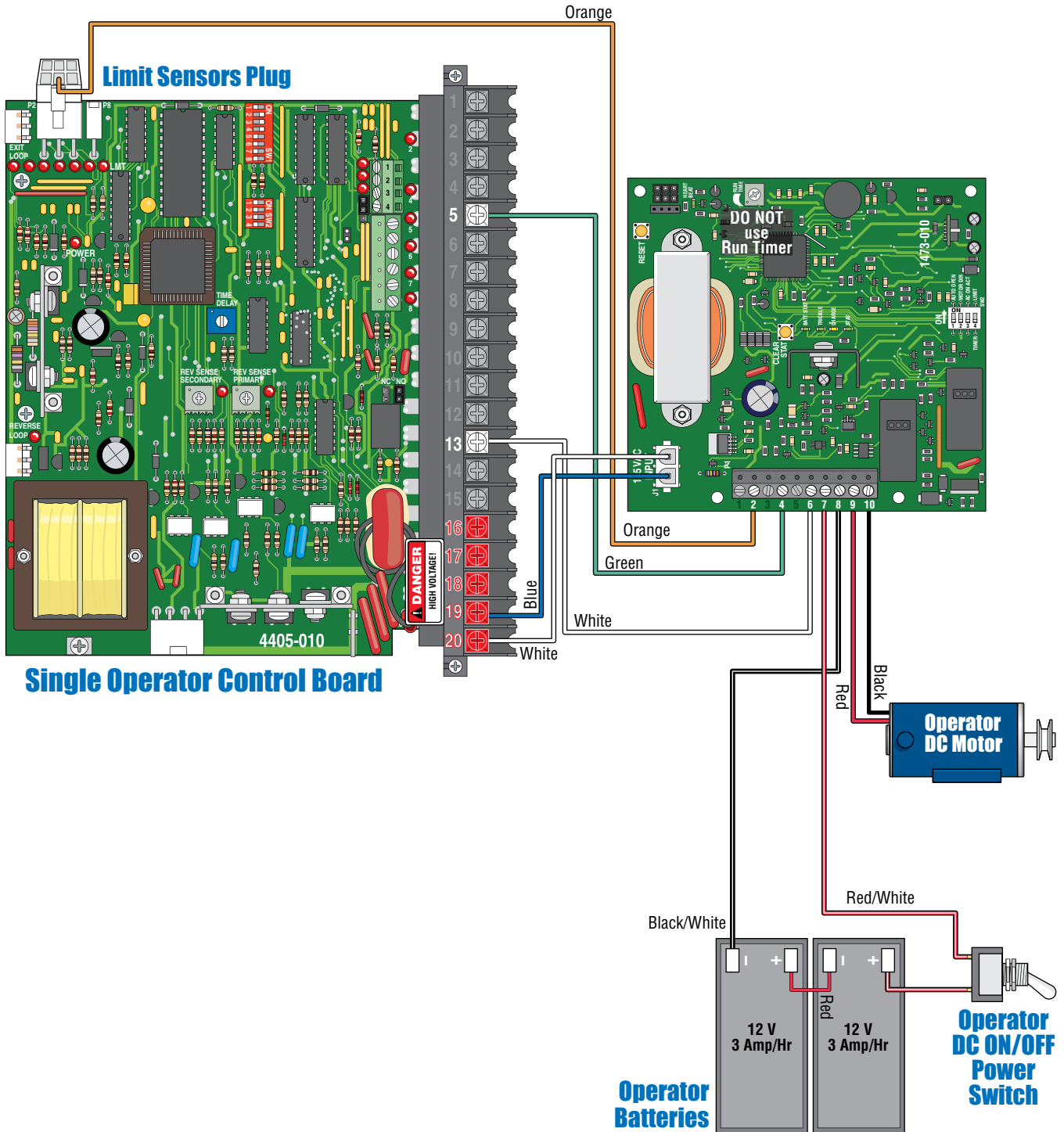

6500 Bi-Parting Swing Gate Operators



Primary Operator Control Board

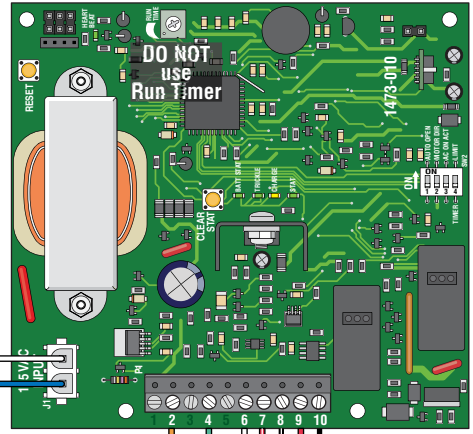
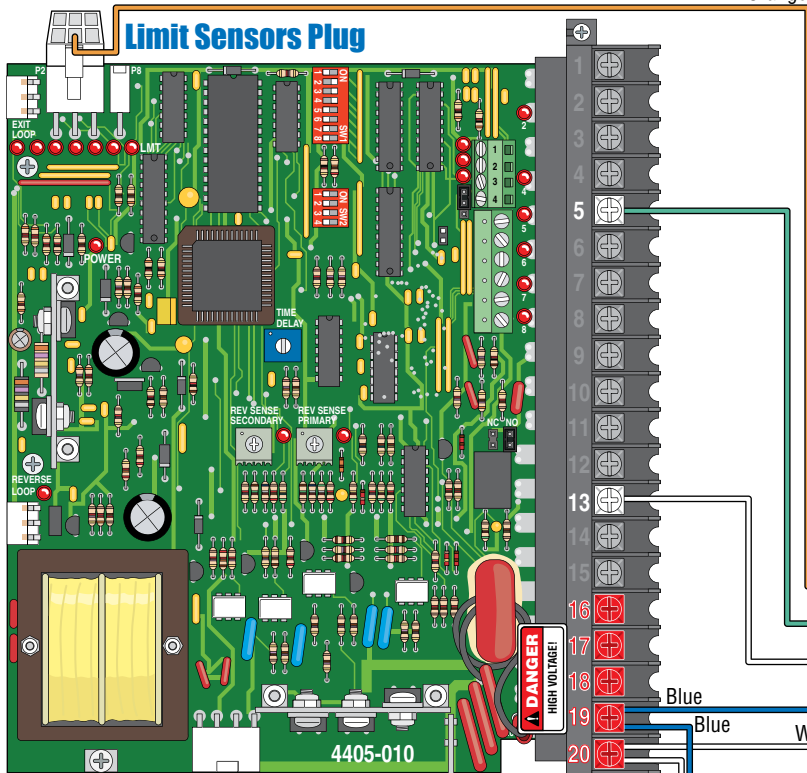

Primary Operator 8-Pin Secondary Interface Terminal

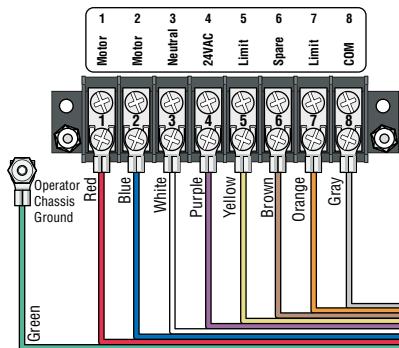

- Operator will **ONLY** function in **auto open mode** (1473 DIP-Switch 1 **ON**).
- 1473 DIP-Switch 4 **MUST** be **ON (Limit)**. This allows the 1473 to use the 6500's magnetic limit for the gate OPEN position.

SECONDARY operator's 1473 board's 115VAC Input **MUST** interconnect to PRIMARY main terminals #19-Blue & #20-White.

Secondary 1473 Control Board

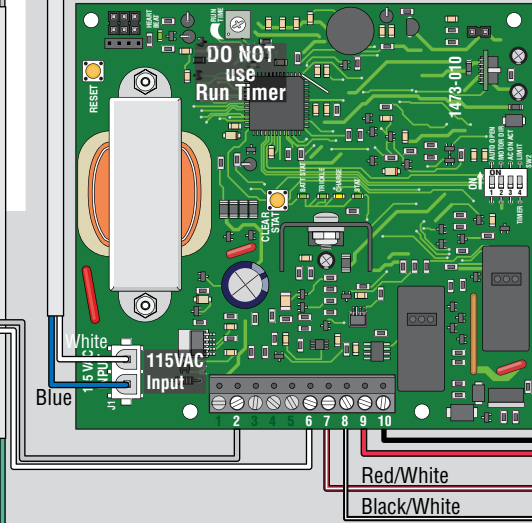

DoorKing Interconnection Cable

Sold Separately

Secondary Operator Terminal

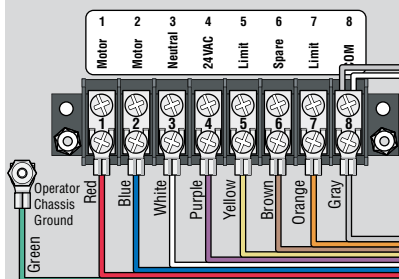

Primary DC ON/OFF Power Switch

Primary Batteries

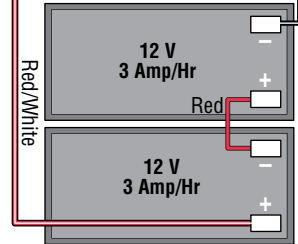

Secondary DC Motor

Secondary DC ON/OFF Power Switch

Secondary Batteries

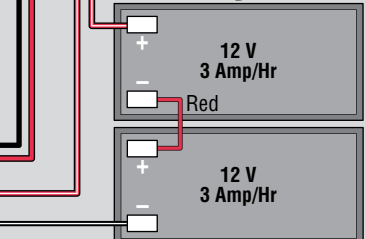

9150 Single Slide Gate Operator

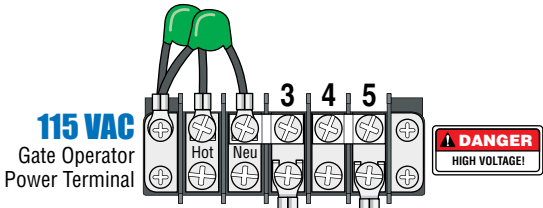

Single Operator Control Board

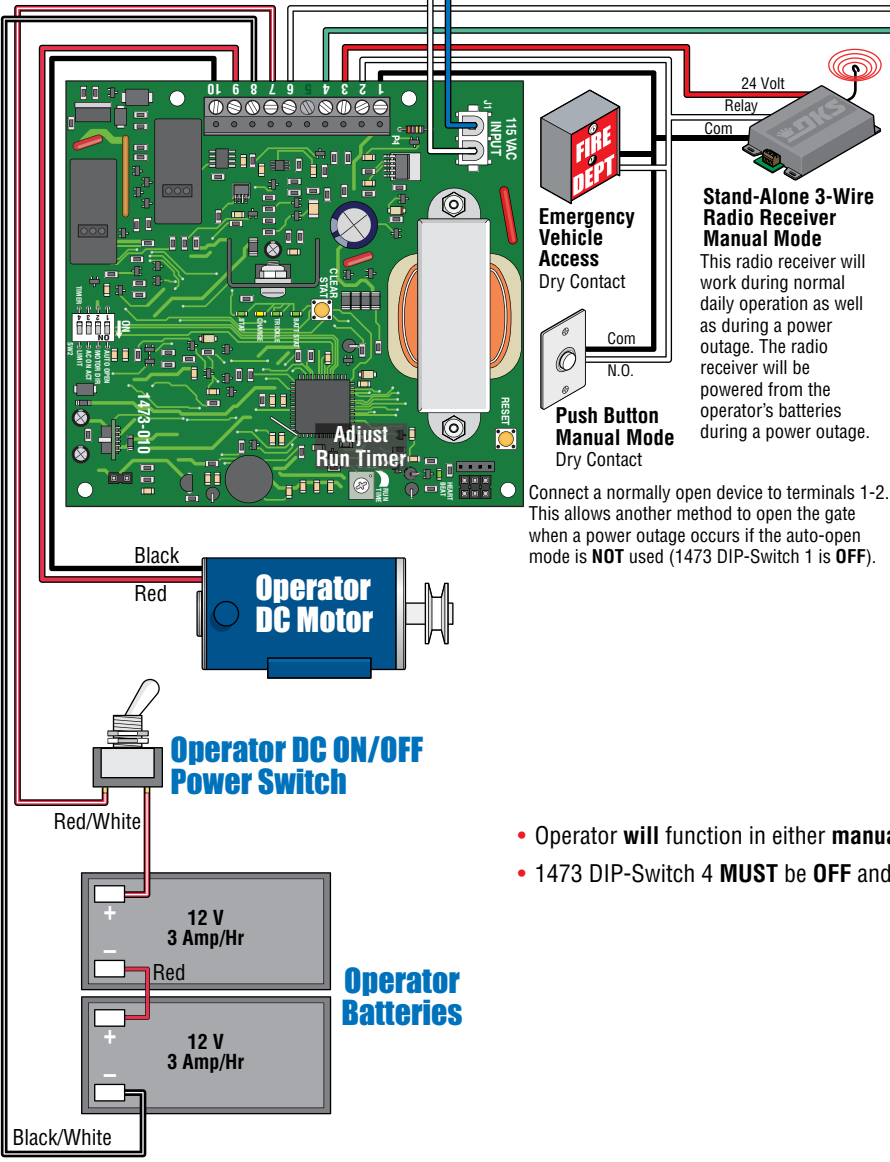
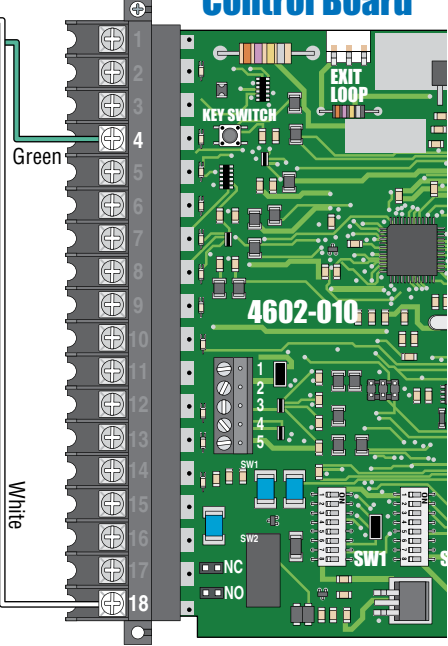

Emergency Vehicle Access
Dry Contact

Stand-Alone 3-Wire Radio Receiver Manual Mode
This radio receiver will work during normal daily operation as well as during a power outage. The radio receiver will be powered from the operator's batteries during a power outage.

Push Button Manual Mode
Dry Contact

Connect a normally open device to terminals 1-2. This allows another method to open the gate when a power outage occurs if the auto-open mode is **NOT** used (1473 DIP-Switch 1 is **OFF**).

- Operator **will** function in either **manual** or **auto open** mode (1473 DIP-Switch 1).
- 1473 DIP-Switch 4 **MUST** be **OFF** and run timer **MUST** be adjusted.

9150 Bi-Parting Slide Gate Operators

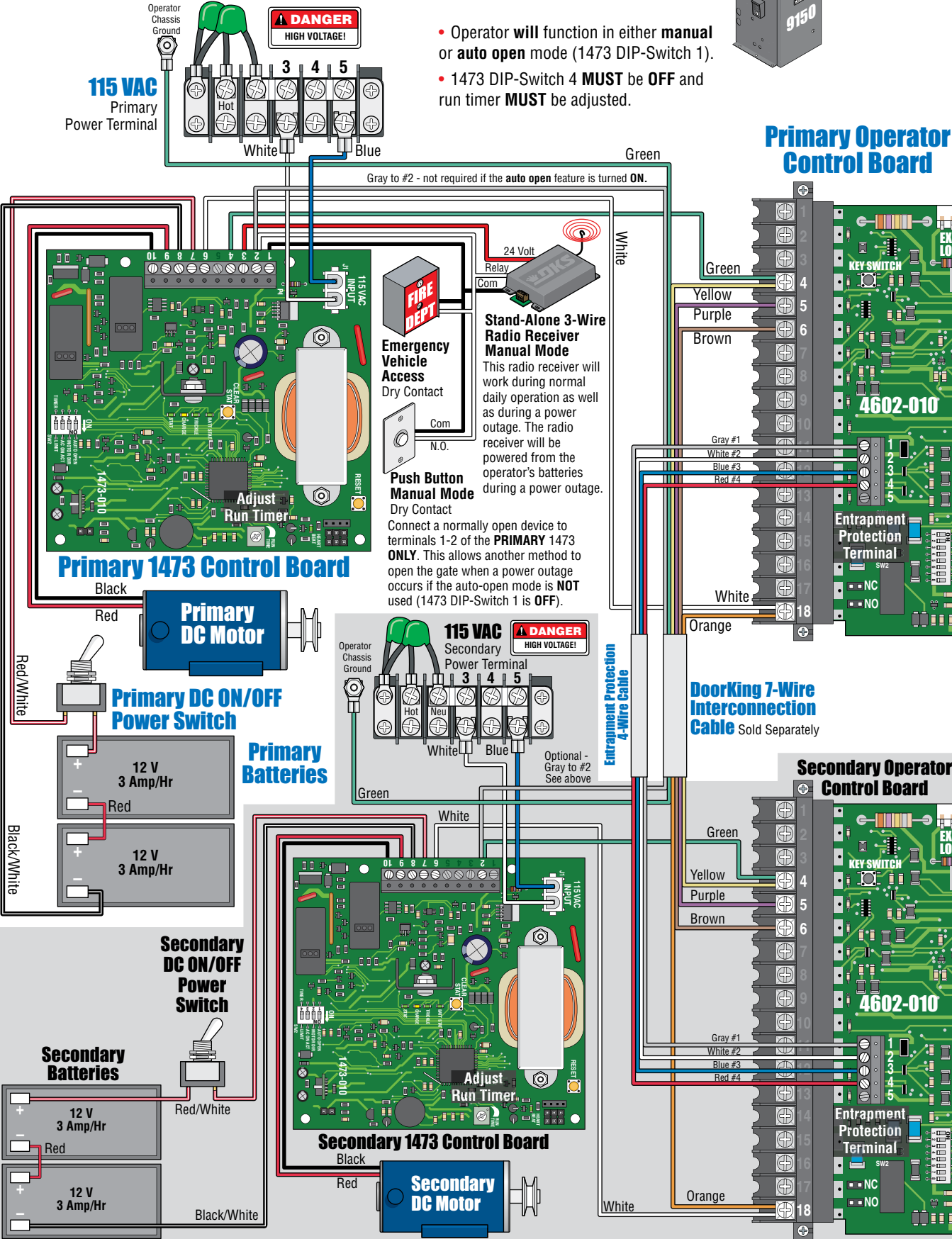

- Operator will function in either **manual** or **auto open** mode (1473 DIP-Switch 1).
- 1473 DIP-Switch 4 **MUST** be **OFF** and run timer **MUST** be adjusted.

9310 Single Slide Gate Operator



- Operator will **ONLY** function in **auto open** mode (1473 DIP-Switch 1 **ON**).
- 1473 DIP-Switch 4 **MUST** be **ON (Limit)**. This allows the 1473 to use the 9310's magnetic limit for the gate OPEN position.

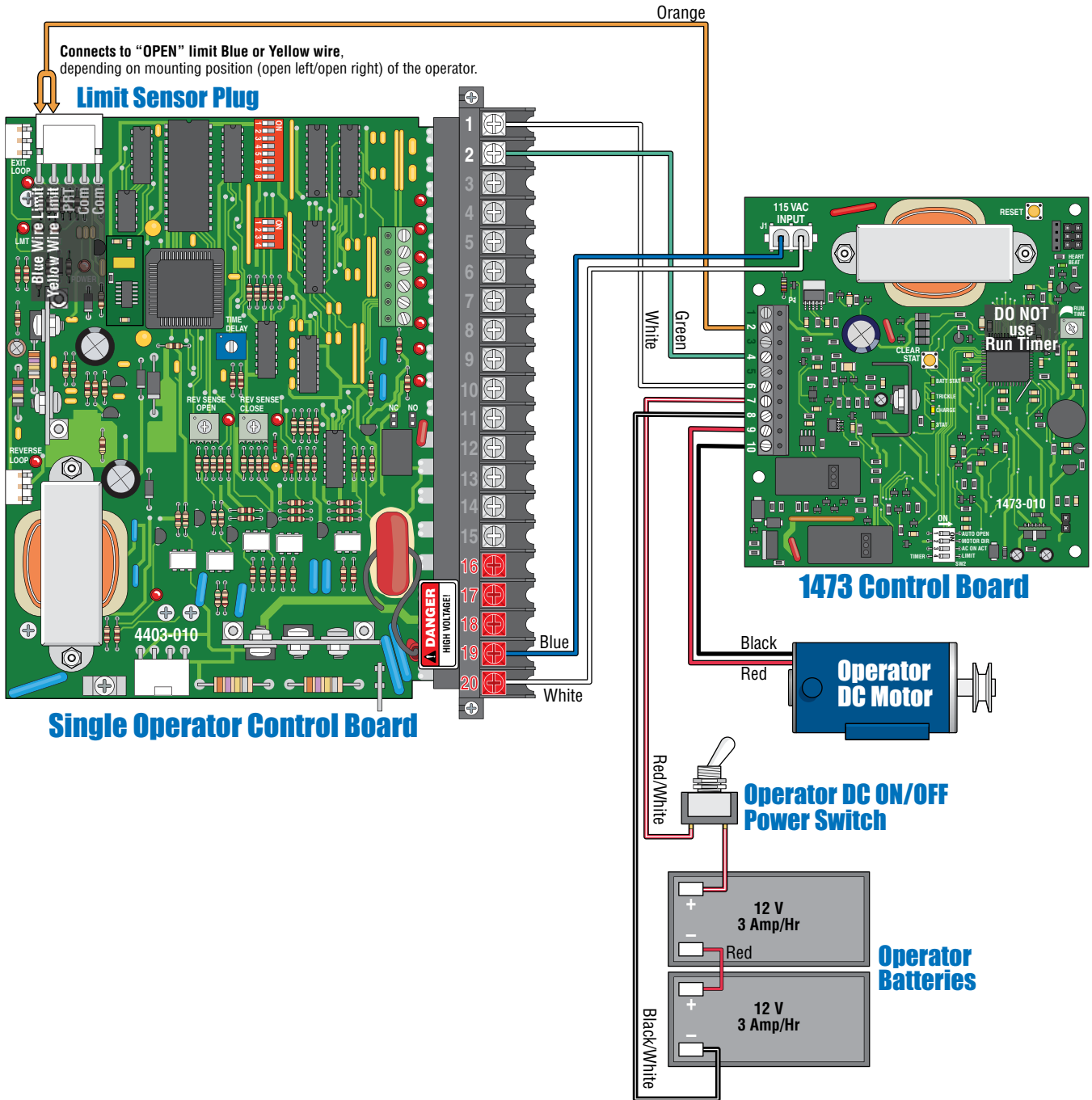

9310 Bi-Parting Slide Gate Operators



Connects to "OPEN" limit Blue or Yellow wire, depending on mounting position (open left/open right) of the operator.

Limit Sensor Plug

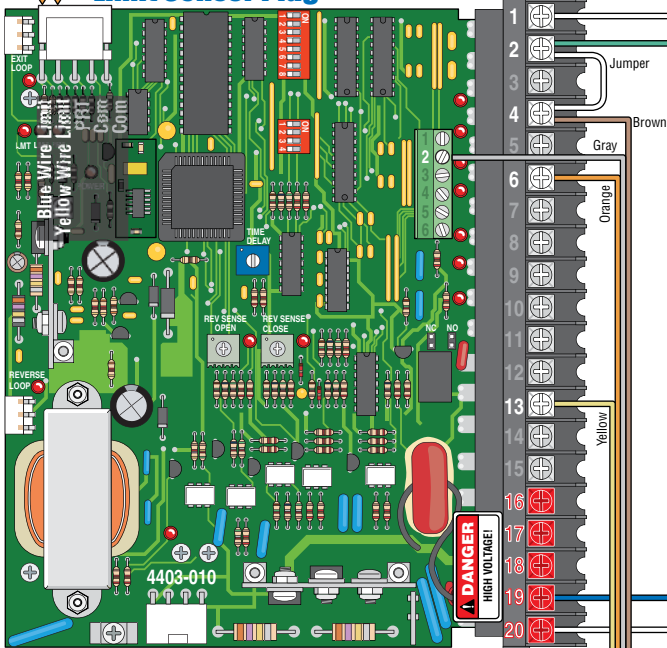

Primary Operator Control Board

- Operator will **ONLY** function in **auto open** mode (1473 DIP-Switch 1 **ON**).
- 1473 DIP-Switch 4 **MUST** be **ON (Limit)**. This allows the 1473 to use the 9310's magnetic limit for the gate OPEN position.

DoorKing Interconnection Cable Sold Separately

1473 Control Board

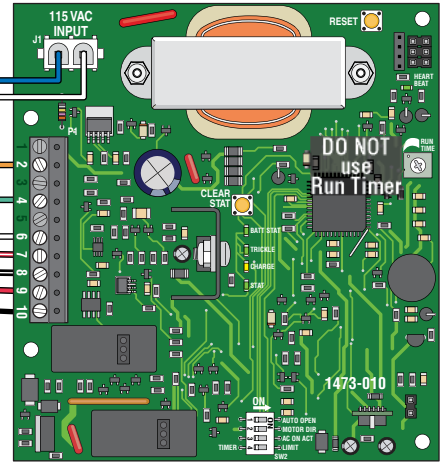

Primary DC ON/OFF Power Switch

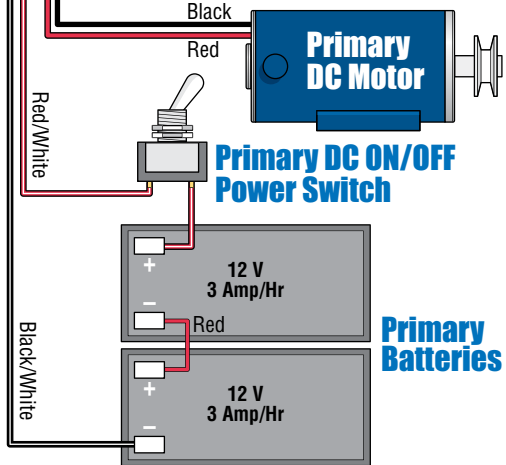

Primary Batteries

Connects to "OPEN" limit Blue or Yellow wire, depending on mounting position (open left/open right) of the operator.

Limit Sensor Plug

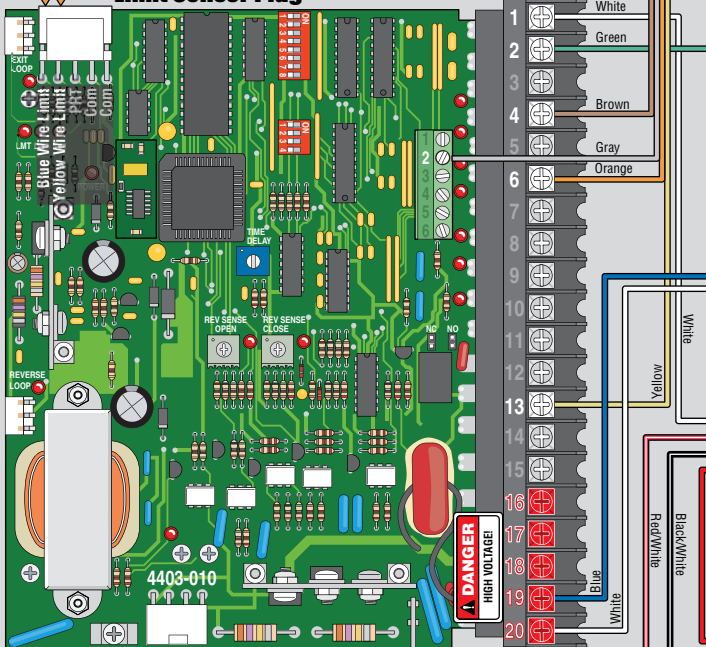

Secondary Operator Control Board

Secondary 1473 Control Board

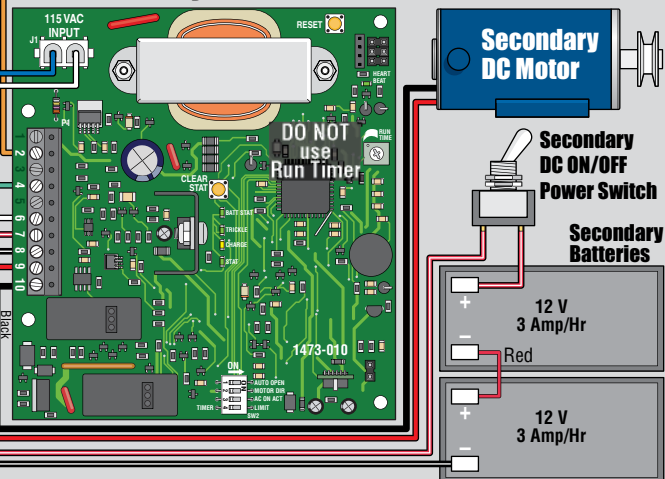

Secondary DC Motor

Secondary DC ON/OFF Power Switch

Secondary Batteries

1601, 1602, 1603 Single Barrier Gate Operator

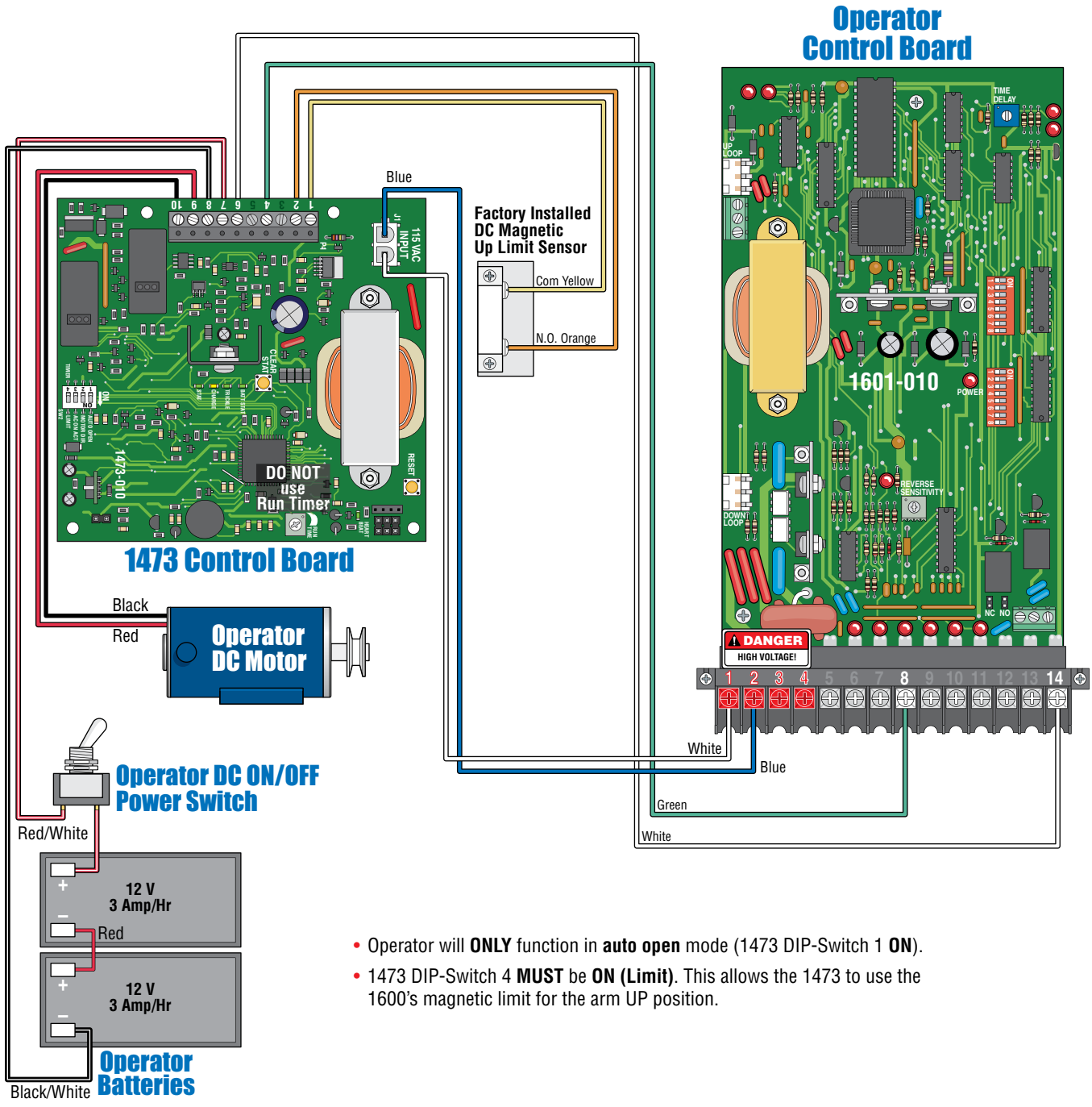
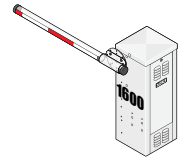

- Operator will **ONLY** function in **auto open** mode (1473 DIP-Switch 1 **ON**).
- 1473 DIP-Switch 4 **MUST** be **ON (Limit)**. This allows the 1473 to use the 1600's magnetic limit for the arm UP position.

1601, 1602, 1603 Bi-Parting Barrier Gate Operators

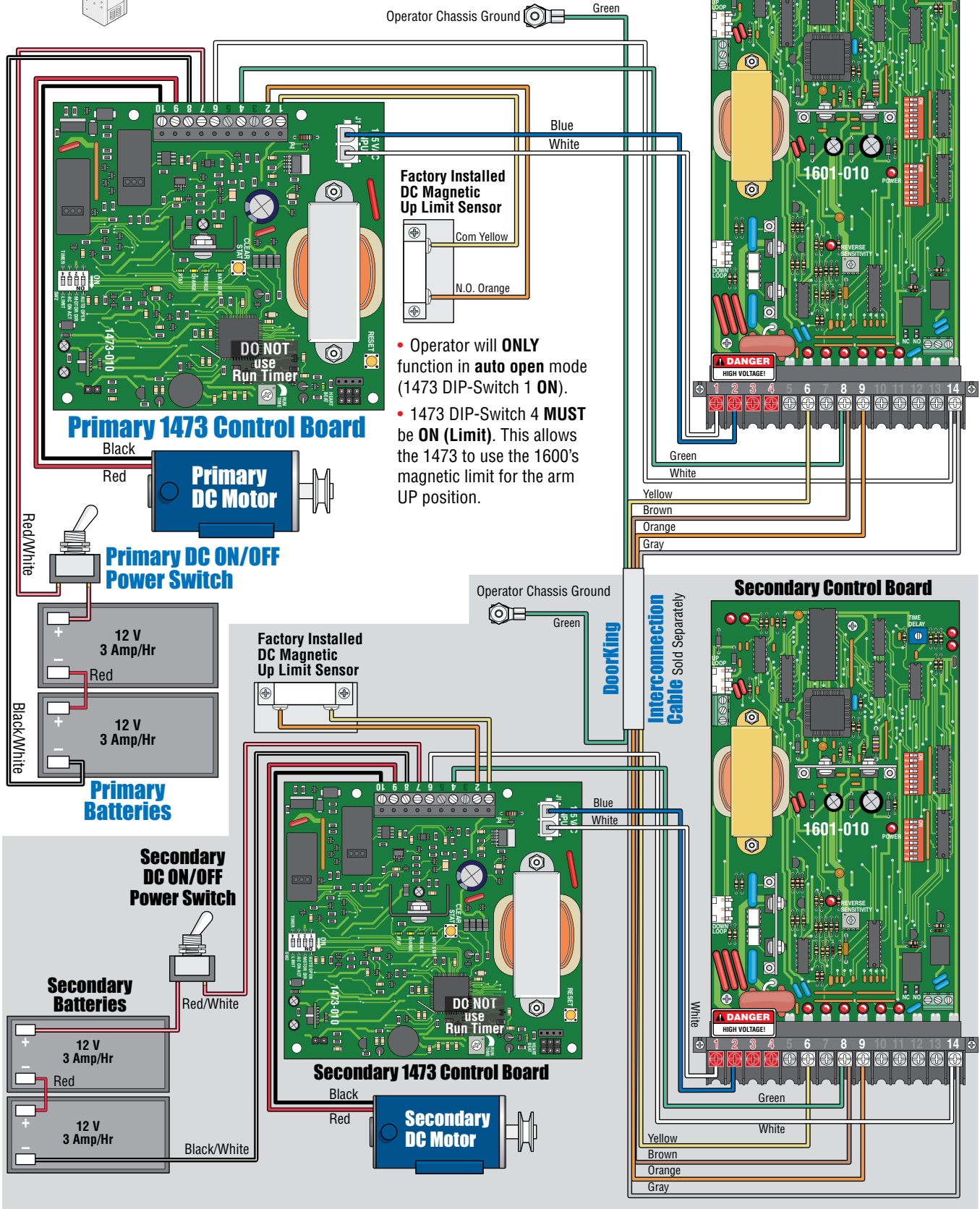
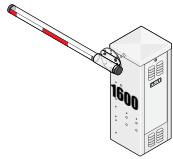

Replacement Parts for Convenience Open System

Part Number	Quantity	Description
1473-010	1	Control Board
1801-009	2	Battery, 12 Volt, 3.0 Amp Hour
1601-041	1	Toggle Switch
2600-196	1	DC Motor Assembly
1601-253	1	Magnetic Sensor Switch, Barrier Operators Only
2600-817	1	Magnet, Barrier Operators Only
2600-688	1	V-Belt
7082-010	1	115 VAC Cable Harness

Battery
12 Volt 3 Amp/Hr
P/N 1801-009
Two (2) required.

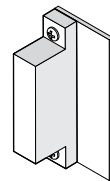
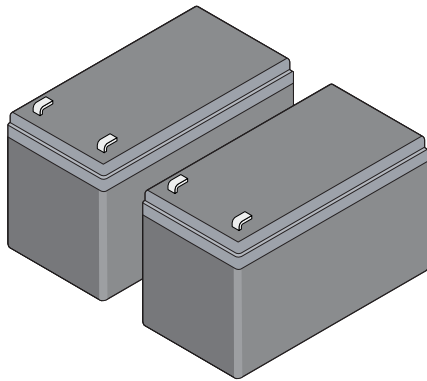

Magnetic Sensor Switch
P/N 1601-253
Barrier Operators Only



Magnet
P/N 2600-817
Barrier Operators Only

Toggle Switch
P/N 1601-041

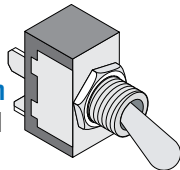

115 VAC Cable Harness
P/N 7082-010

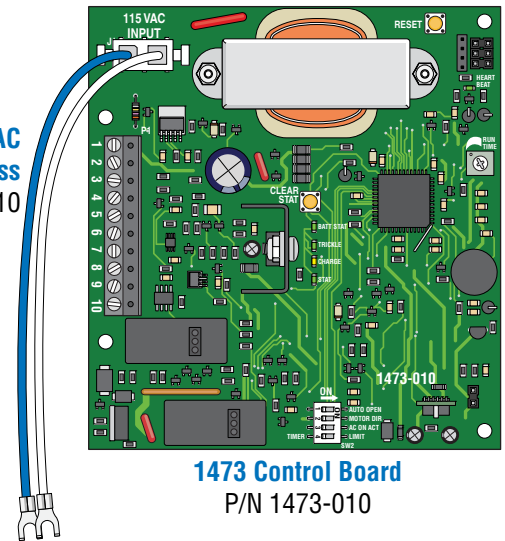

1473 Control Board
P/N 1473-010

1473 Control Board Kit
P/N 1473-121
Control board, wire harness
and installation manual

V-Belt
P/N 2600-688

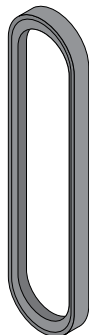

DC Motor
P/N 2600-196

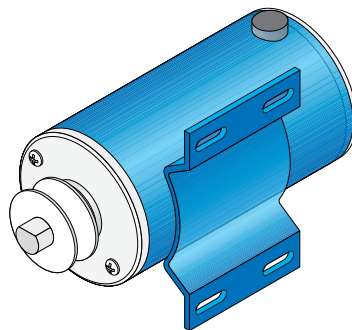

Installation Manual

Replacement Convenience Open Board For Pre-2016 Convenience Open Operators **ONLY**

Use this manual for circuit board 1473-010.

1473-065-€-2-18

For **Pre-2016** Convenience Open Models:
1600, 1602, 1603, 6100, 6300, 6500, 9150 and 9310 Operators **ONLY**

Replacement Board for
2340-010 Convenience Open Board



www.doorking.com

DoorKing, Inc.
120 S. Glasgow Avenue
Inglewood, California 90301
U.S.A.

Phone: 310-645-0023
Fax: 310-641-1586