



barrier gate operator installation guide
for use with models
1601-080/081
1602-080/081
with circuit board 1601-010 rev.V or higher

supplemental manual available
(P/N 2340-065) for 1601-081, 1601-088
and 1602-081 for optional battery
backup system with additional wiring
information.

DKS DoorKing, Inc.
120 Glasgow, Avenue
Inglewood, Ca. 90301

310.645.0023
310.641.1586 fax
www.doorking.com
info@doorking.com

copyright © 2006 DoorKing, Inc.
All rights reserved.

notice of rights

The content in this manual is protected
under copyright law and no portion
of this manual may be copied,
reproduced, translated, or converted
to any electronic medium without prior
written consent.

notice of liability

DoorKing, Inc. reserves the right to make
changes in the products described
in this manual without notice and/or
obligation to notify any persons of any
revisions or changes. DoorKing, Inc.
makes no representations or warranties
with respect to this manual.

publication number



1601-065-M-05-07

general information

safety information.....	4
glossary.....	5
specifications.....	6

operator installation

surface operator.....	7
-----------------------	---

electrical installation

main terminal wiring.....	9
high voltage wiring.....	10
low voltage wirng.....	11
primary/secondary control wiring.....	12
pams wiring.....	13
gate tracker wiring.....	14
loop detector wiring.....	15
entry lane application.....	16
exit lane application.....	17
ticket spitter application.....	18
two-way lane application.....	19
timer down application.....	20

arm installation

hub.....	21
aluminum-plastic-wood.....	22
wishbone.....	23

settings

control board.....	24
magnetic limit.....	25
direction check.....	26
reverse sensitivity.....	27
switch descriptions & functions.....	28

accessory installation

reversing edge.....	29
fan kit.....	30
heater kit.....	31

technical information

wiring diagram.....	32
wiring diagram-convenience open.....	33
maintenance schedule.....	34
troubleshooting.....	35
accessories.....	36

save this installation guide for reference

► **Reduce the risk of injury or death, read and follow all instructions.**

Familiarize yourself with safety warnings, instructions, illustrations, and wiring guidelines to ensure that the installation is performed in a safe and professional manner.

Prior to installation **check all local building codes and ordinances to ensure compliance.**

Speed limit through barrier area is 5 MPH. Install speed bumps and warning signs where visible in the area of the gate, failure to do so may result in injury, damage to operator and vehicle.

Users should be familiar with proper use of operator, these include; hardware operation, reversing functions and testing, reversing loops, inherent reversing system, electric edges, photoelectric cells related external devices and possible hazards.

Keep adults, children and objects away from operator and HAZARD ZONES. Pedestrians must be provided with a separate access.

All electrical connections should be made in accordance with local electrical codes.

Security features should be installed to **avoid unauthorized use.**

Controls must be installed away from the operator (min. 10' ft. away) to avoid any contact when operating the controls. If the installed hardware is in violation of these restrictions remove the operator from service immediately and contact your service dealer.

When removing the operator lift the arm to the full open position and **shut off power at the service panel.**

Operators and components should be properly installed and maintained following the recommended service schedule, test the operator monthly. Contact your service dealer for any maintenance or repairs.

Vehicular operators can produce high levels of force, it is important that you are aware and **eliminate possible HAZARDS; Pinch Points, Entrapment, Absence of Controlled Pedestrian Access, Traffic Backup.**

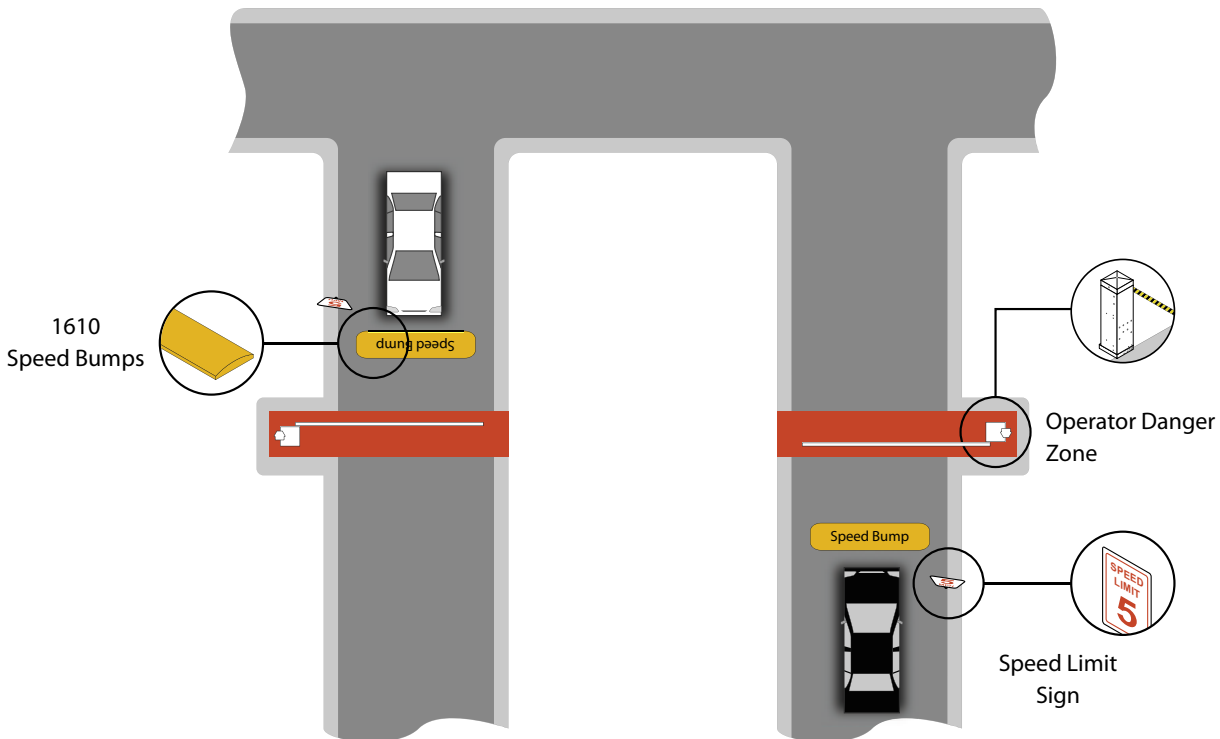

RESIDENTIAL VEHICULAR OPERATOR-CLASS - A vehicular operator (or system) intended for use in a home of one-to-four single family dwelling, garage or parking area associated therewith.

COMMERCIAL / GENERAL ACCESS VEHICULAR OPERATOR-CLASS II - A vehicular gate operator (or system) intended for use in a commercial location or building such as a multi-family housing unit (five or more single family units), hotels, garages, retail store or other building servicing the general public.

INDUSTRIAL / LIMITED ACCESS VEHICULAR OPERATOR-CLASS III - A vehicular gate operator (or system) intended for use in an industrial location or building such as a factory or loading dock area or other locations not intended to service the general public.

RESTRICTED ACCESS VEHICULAR OPERATOR-CLASS IV - A vehicular gate operator (or system) intended for use in a guarded industrial location or building such as an airport security area or other restricted access locations not servicing the general public, where unauthorized access is prevented via supervision by security personnel.

SYSTEM - In the context of these requirements, a system refers to a group of interacting devices intended to perform a common function.

WIRED CONTROL - A control implemented in a form of fixed physical interconnections between the control, associated devices and an operator to perform predetermined functions in response to input signals.

WIRELESS CONTROL - A control implemented in means other than fixed physical interconnections (such as radio waves or infrared beams) between the control, the associated devices and an operator to perform predetermined functions in response to input signals.

INHERENT ENTRAPMENT SENSOR SYSTEM - An automatic sensor system that senses entrapment of a solid object and is incorporated as a permanent and integral part of the operator.

ENTRAPMENT - The condition when an object is caught or held in a position that increases the risk of injury.

general information/specifications

operator

The 1601 operator has been designed for high usage single lane (14 feet maximum) vehicular traffic control.

class:

II, III, IV

horsepower:

1/2 or 1 HP

housing:

G90 galvanized steel, painted white.

mechanical:

worm gear running in a continuous oil bath.

release method:

fail-secure mechanical

operation temperature:

10°F to 140°F

-12°C to 62°C

voltage:

115/230/460 VAC

note: 230 and 460 VAC units use a stepdown transformer to achieve 115 VAC operating voltage.

arm:

wood/aluminum

loop detectors:

Port for plug-in open (up) detector

Port for plug-in reverse (down) detector

DKS Detectors Only

advanced features:

Auto Close Timer 1-23

Electronic Limits

Gate Tracker

Left/Right Mount

safety Listing:

Complies with UL 325 and UL 991 safety standards.

ETL Listed

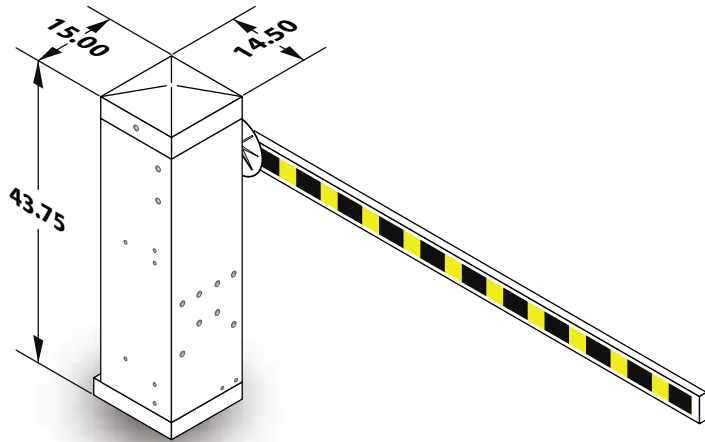

! The operator must be installed on a concrete base. Soil conditions and local building codes will determine concrete base depth and width.

- For added support use rebar and/or wire mesh.
- Concrete base should be even and leveled avoiding any operator unbalance.
- Mix concrete according to manufacturer.
- Pour and tamp concrete into form.
- Level and surface.
- Allow concrete to cure for 48 hrs.

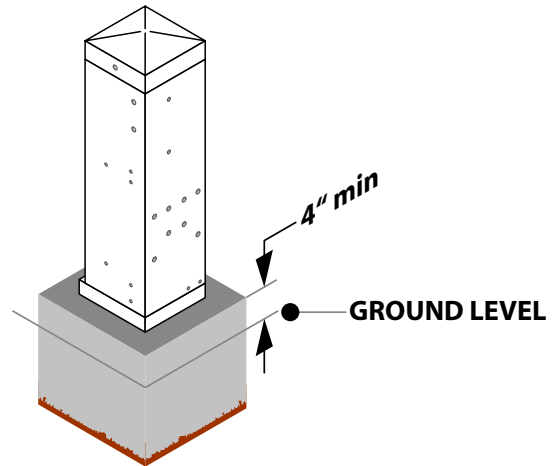

! Concrete must be even and leveled, avoiding any operator unbalance and unevenness. Conduit requirements may vary depending on your specific needs. Use only sweeps for conduit bends, do not use 90° connectors this will make wire pulls very difficult and can cause damage to wire insulation. A suggested minimum of 3/4-inch conduit should be used. Be sure that all conduits are installed in accordance with local codes.

- 1** From the operator position dig a trench. **NOTE: The trench should enclose the conduits.**
- 2** Run conduits from the operator to their corresponding source .
- 3** Mix and pour concrete into the trench, allow the concrete to cure and place the operator into position.

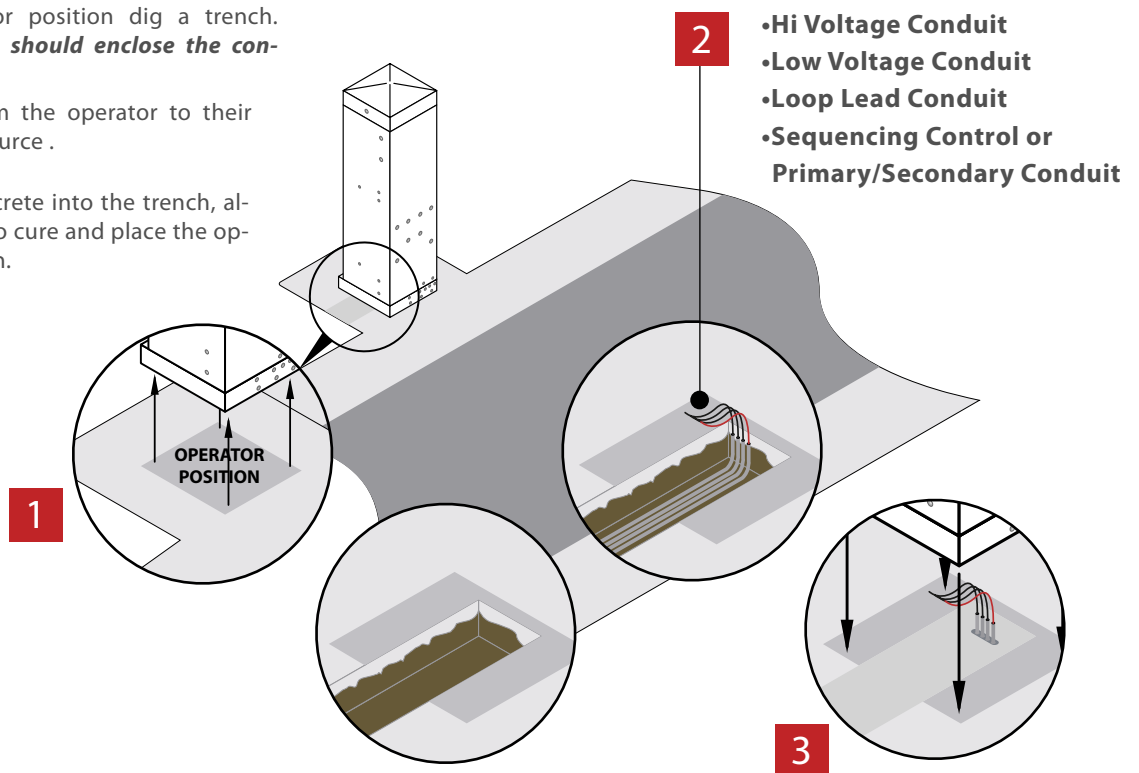

operator installation/surface operator

- 1** Set the operator in place and mark the position for the sleeve anchors.
- 2** Drill the mounting holes (remove all debris), recommended sleeve anchor sizes are 3/8 x 3 or 1/2 x 3, anchors are not included.
- 3** Place the operator into position and bolt down using the sleeve anchors.

The operator's access door must face the opposite side of traffic.

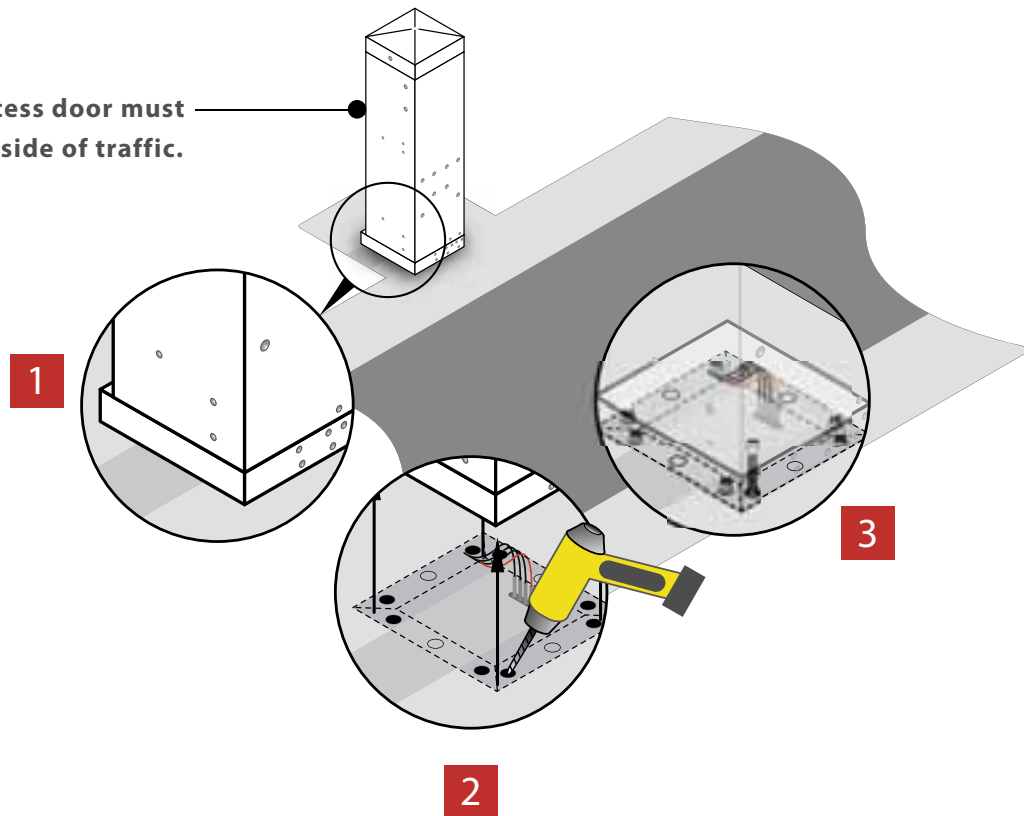

1. **115 VAC NEUTRAL**
2. **115 VAC POWER**
3. **115 VAC MOTOR POWER**
4. **115 VAC MOTOR POWER**
5. **24 VAC RADIO RECEIVER POWER ONLY (200 ma. max)**
6. **UP INPUT** - Function is dependent on the setting of programming switch 6. When switch 6 is OFF, this input will cause the operator to rotate the arm to the up position. If the arm is in the down cycle, this input will reverse the arm to the up position. If this terminal has a constant input, the arm will remain in the up position regardless of any down input or timer command to rotate down. When switch 6 is ON, this input will cause the operator to rotate the arm to the up position when it is down, and will cause the operator to rotate the arm to the down position when it is up. If the auto timer is turned ON, this input will override the timer and rotate the arm to the down position. If the arm is in the down cycle, this input will reverse the arm to the up position.
7. **UP LOOP OUTPUT** - Function is dependent on the setting of programming switch 8. When switch 8 is ON, the function of this input is identical to terminal 6 above. When switch 8 is OFF, this terminal becomes the logic output of the up loop detector.
8. **DOWN / REVERSE INPUT** - Function is dependent on the setting of programming switches 1 and 4. With switch 1 OFF and switch 4 ON, activation and then deactivation of this input will rotate the arm to the down position, provided that the deactivation of the input happens while the arm is in the full up position. This input will override the auto timer if it is turned ON. If the arm is in the down position, traveling in the down cycle, or traveling in the up cycle, activation and deactivation of this input has no effect on the arm. With switches 1 and 4 ON, activation and then deactivation of this input will rotate the arm to the down position after it reaches the full up position regardless of when the deactivation of the input occurred. When switch 4 is OFF, this input is identical to the reverse input, terminal 9.
9. **REVERSE INPUT** - When the arm is in the down position, activation of this input has no effect. When the arm is in the up position, activation of this input will prevent the arm from rotating to the down position. If the arm is in the down cycle, activation of this input will reverse the arm to the up position.
10. **MOMENTARY UP INPUT** - This input is used when sequencing the 1601 with a slide or swing gate operator in PAMS applications. Activation of this input will rotate the arm to the up position one time, and activates the enable up input.
11. **ENABLE UP INPUT** - This input is used when sequencing the 1601 with a slide or swing gate operator in PAMS applications. This input is only active after a MOMENTARY UP input is received. Activation of this input will rotate the arm to the up position or reverse an arm in the down cycle to the up position.
12. **RELAY CONTACT** - Function is dependent on the setting of programming switch 5. When switch 5 is OFF, activation of the down loop will activate the relay. When switch 5 is ON, activation of the UP loop will activate the relay. Relay contacts can be set for N.O. or N.C. by placing the relay contact jumper on the appropriate pins.
13. **RELAY CONTACT** - Same as above
14. **LOW-VOLT COMMON**

NOTE:
 • See page 28 for switch settings and options.
 • DC power is not present on the board until the first initial cycle.

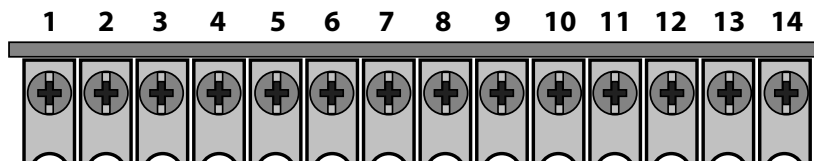

electrical installation/high voltage wiring

MODEL	VOLTS	AMPS	WIRE SIZE / DISTANCE IN FEET			
			12 AWG	10 AWG	8 AWG	6 AWG
1601/1603	120	5.4	170	275	460	685
1601/1603	230	2.7	685	1100	1830	2750
1601/1603	460	1.35	2875	4600	7665	11500

The distance shown in the chart is measured in feet from the operator to the power source. If power wiring is greater than the maximum distance shown, it is recommended that a service feeder be installed. When large gauge wire is used, a separate junction box must be installed for the operator connection. The wire table is based on stranded copper wire. Wire run calculations are based on a 3% voltage drop on the power line, plus an additional 10% reduction in distance to allow for other losses in the system.

! All wiring must comply with local code requirements.

To protect against surges and power fluctuations it is recommended that a surge suppresser be installed on the high voltage power lines

For 230 and 460 Volt 3-phase input power, use only two legs of the incoming 3-phase power.

- 1** From the High-Voltage conduit, route the wiring cable up to the terminal block.
- 2** Connect the High-Voltage wiring to the terminal block as shown.

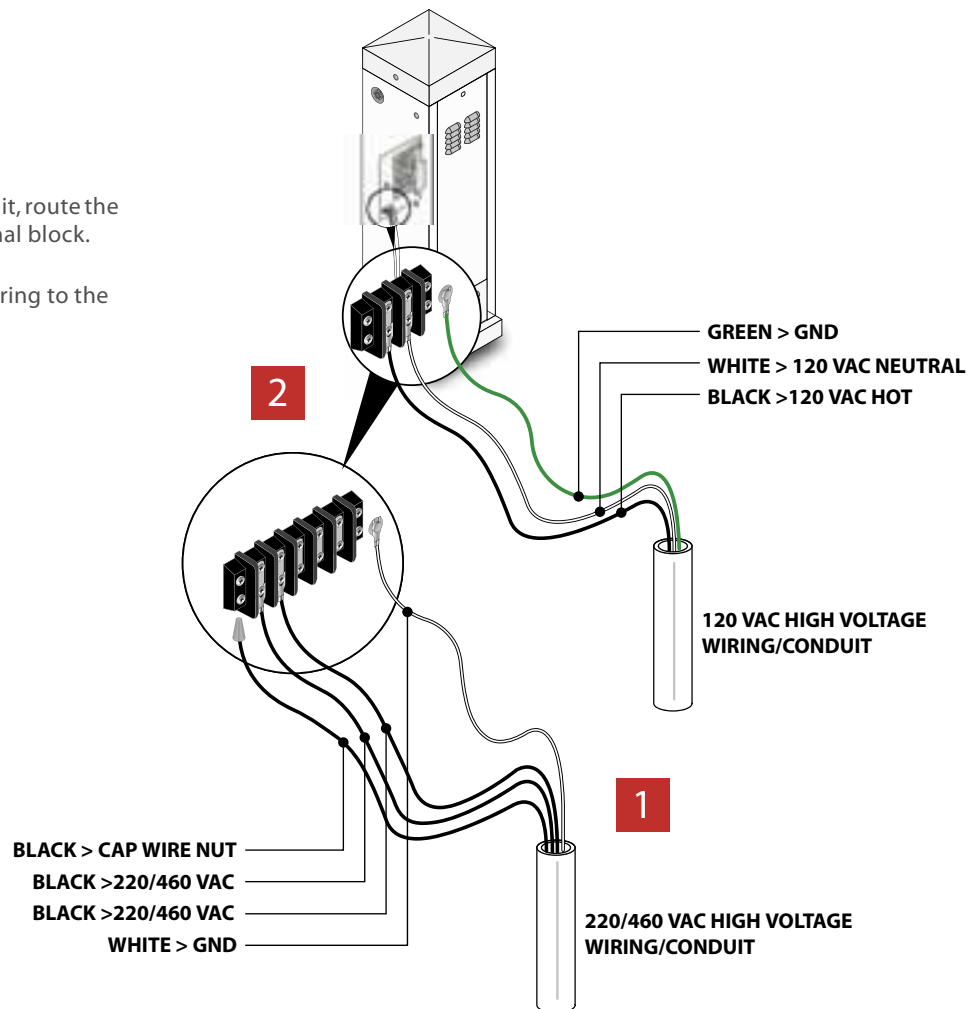

- 1 Connect control devices to the operator terminal strip as shown.
- 2 Accessory items; card readers or keypads must be powered from their own power transformer.

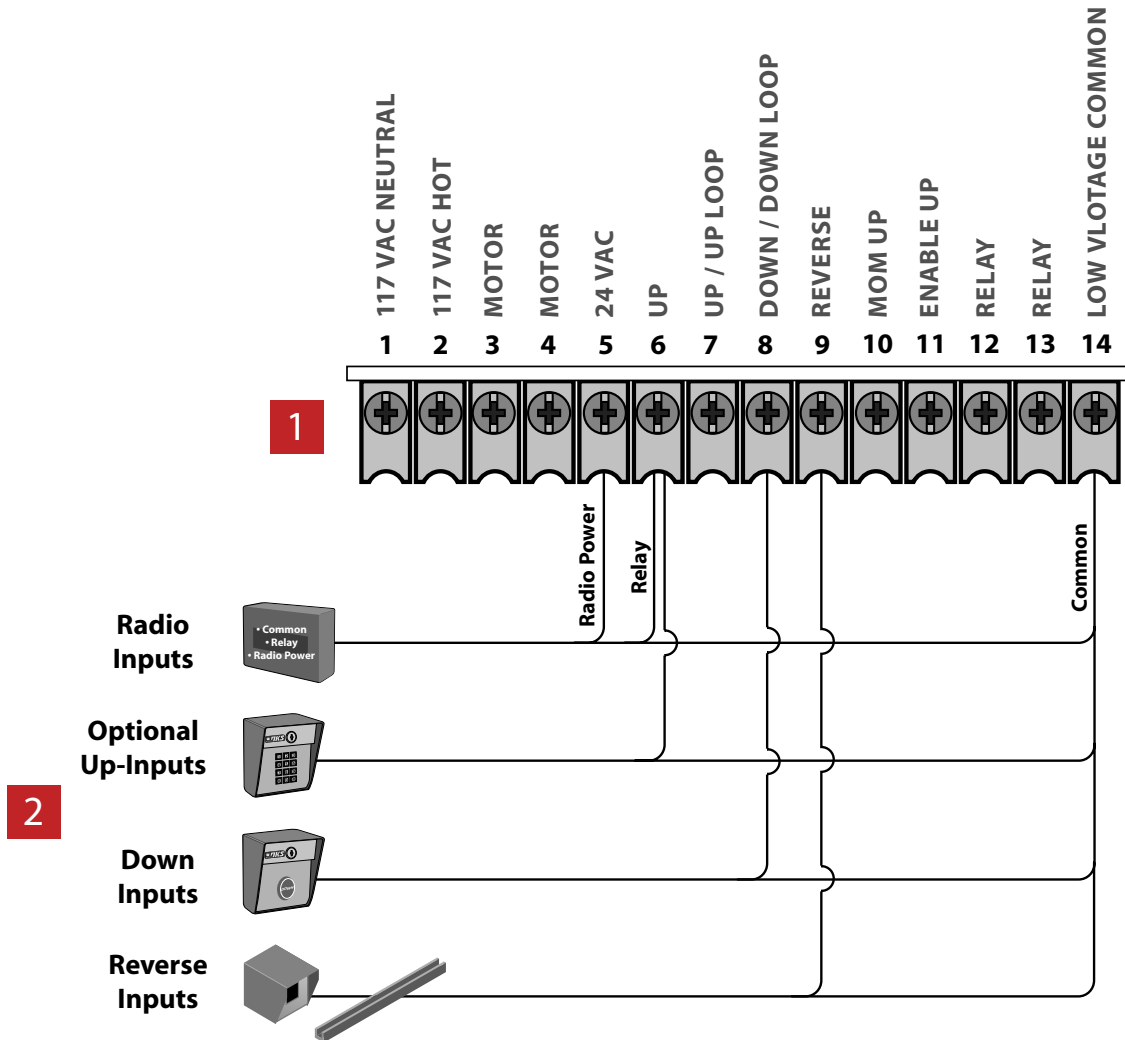

! Controls must be far enough from the barrier operator, preventing contact with the operator/arm while operating the controls. Outdoor or easily accessible controls should have a security feature to prevent unauthorized use.

Do not power any devices from the circuit board other than a low voltage radio receiver.

Connect optional control devices to the main terminal strip. Use 18 AWG wire for all low voltage wiring, maximum distance 3000 feet. Use a low voltage surge suppressor, (DoorKing P/N 1878-010) if low voltage wire runs exceed 1000 feet. All inputs to the terminal strip must be NORMALLY OPEN.

If this operator is part of a Perimeter Access Management System (PAMS), refer to your PAMS wiring manual and section 2.3.3 for interface wiring to the swing or slide gate operator.

electrical installation/primary-secondary control wiring

- 1 Connect the primary/secondary operators as shown.
- 2 Connect operators to its own high voltage power source, refer to the high voltage wiring section on page 10.

3 Switch Settings

- SW1 Switch 5 Off - Relay activates with DOWN LOOP.
- SW1 Switch 6: ON - UP LOOP output from Term 7.
- Set other switches based on gate operation preferences.
- Set both operators switches to the same settings.

! Connect control devices to the primary unit as described in the Low Voltage Wiring section on page 11.

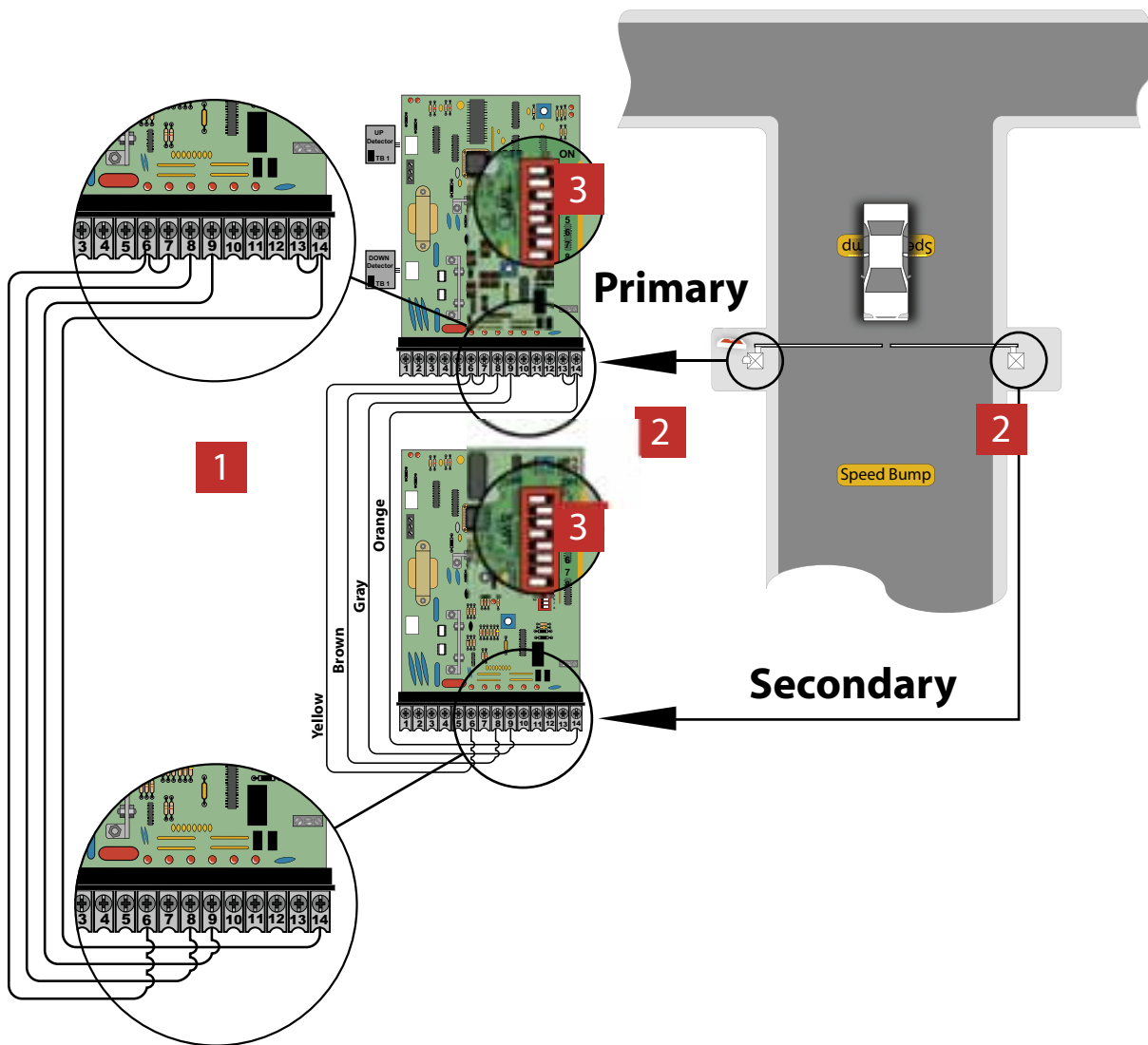

electrical installation/pams wiring

When using the operator in a Perimeter Access Management System (PAMS) application, refer to illustrations for PAMS wiring interface to sequence the barrier operator with the slide or swing gate operator. For detailed PAMS wiring information, refer to the PAMS Technical Information and Wiring Manual.

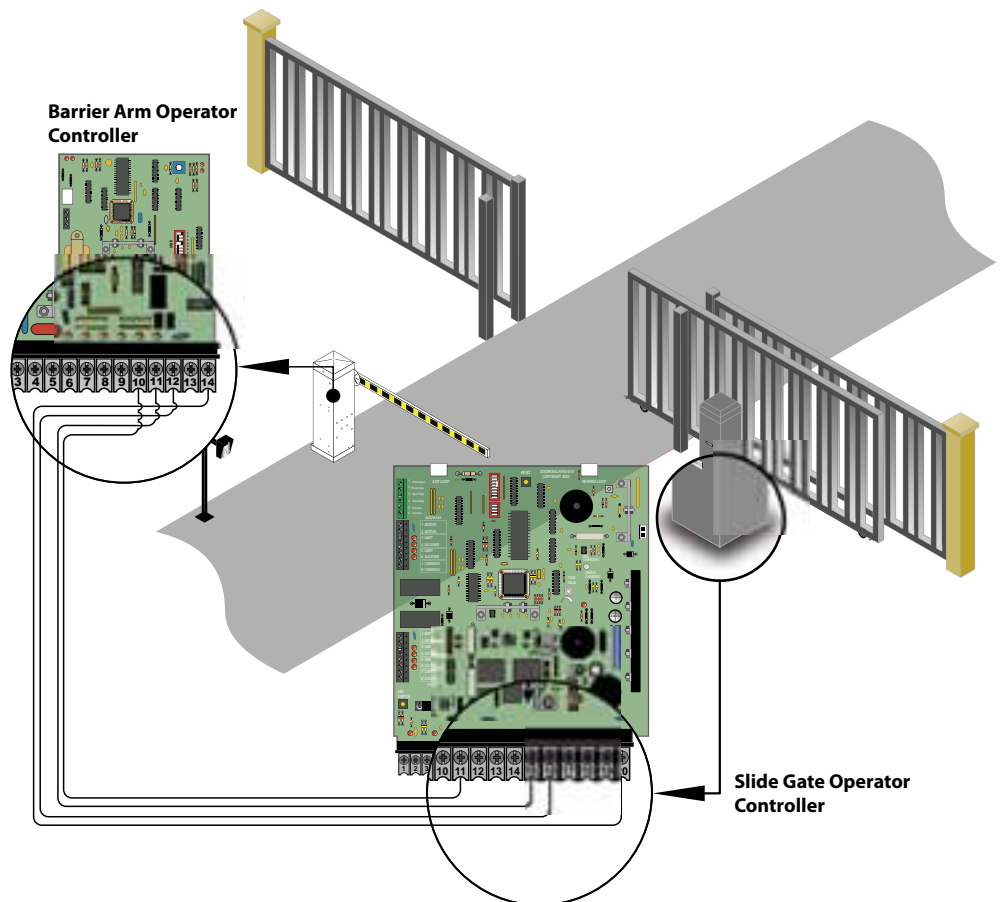
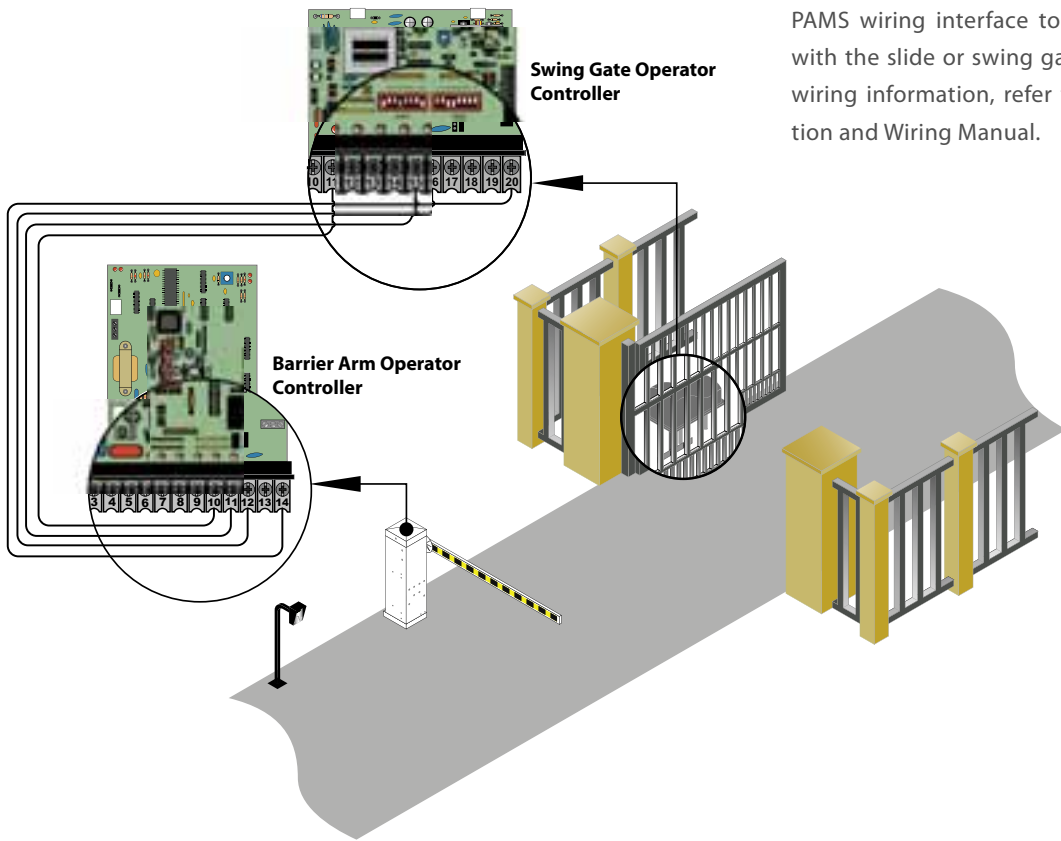

electrical installation/gate tracker wiring

The operator will report status to the DoorKing Access Control System (Model 1803PC, 1815, 1817 or 1818) that is equipped with a Tracker expansion board. This report includes operator cycle count, shorted inputs, loop detector problems, power interruptions, etc.

1 Connect the wiring from the auxiliary terminal strip located on the left side of the circuit board to the Gate Tracker™.

2 Connect the wiring from terminals 5, 6 and 14 on the main terminal strip to the Gate Tracker™.

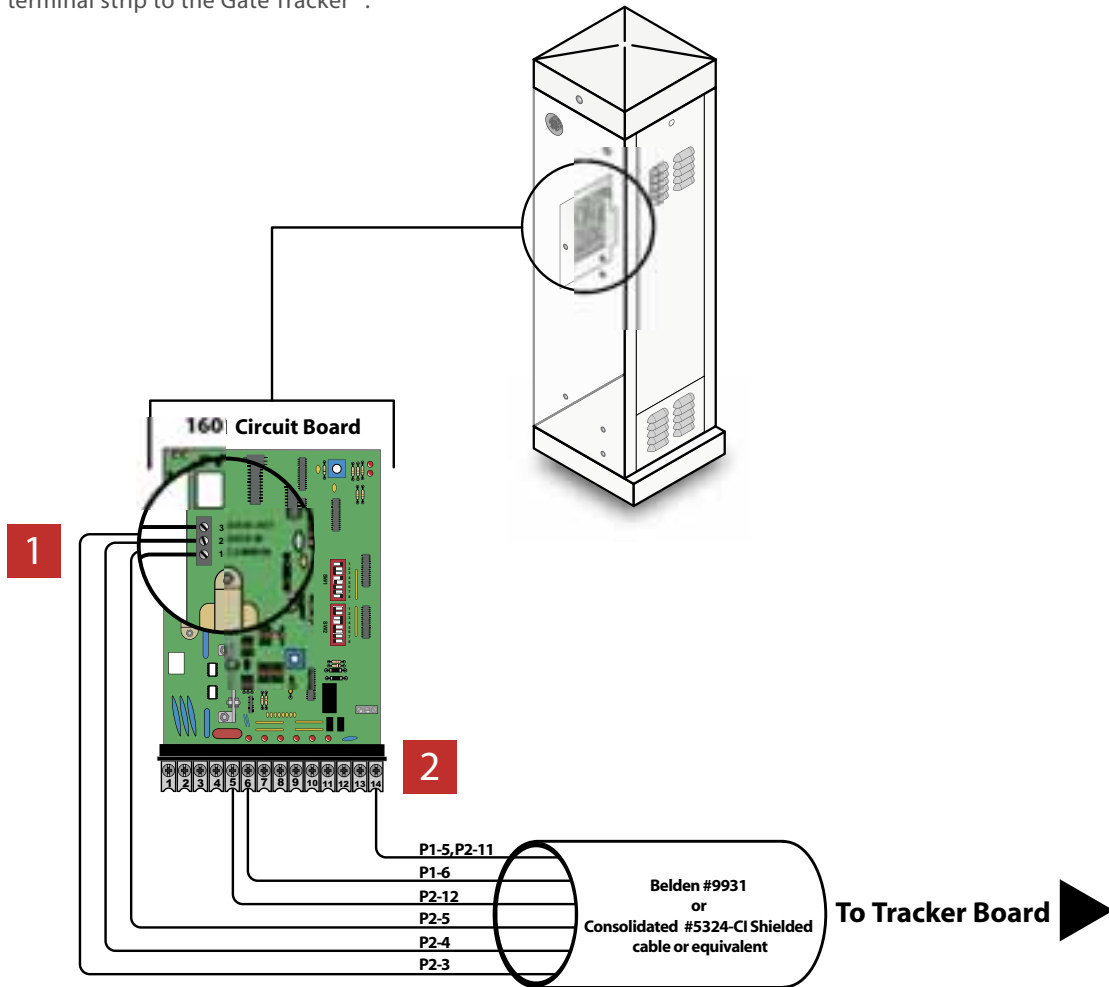

! Maximum wire run for tracker board is 500 feet using Belden #9931 shielded cable or Consolidated #5324-CL shielded cable. Float the shield at the tracker board. Do not connect the shield to the tracker board common.

Wire connection from the tracker board terminal P1-6 to the terminal 6 is optional if the barrier operator is not to be activated by the tracker output relay.

For more detailed information on Gate Tracker™ and wiring to the Tracker expansion boards, refer to the Tracker Installation and Wiring Manual, DoorKing P/N 2351-010.

electrical installation/loop detector wiring

Loop detector wiring shown is for DoorKing model 9405 and 9406 plug-In loop detectors only.

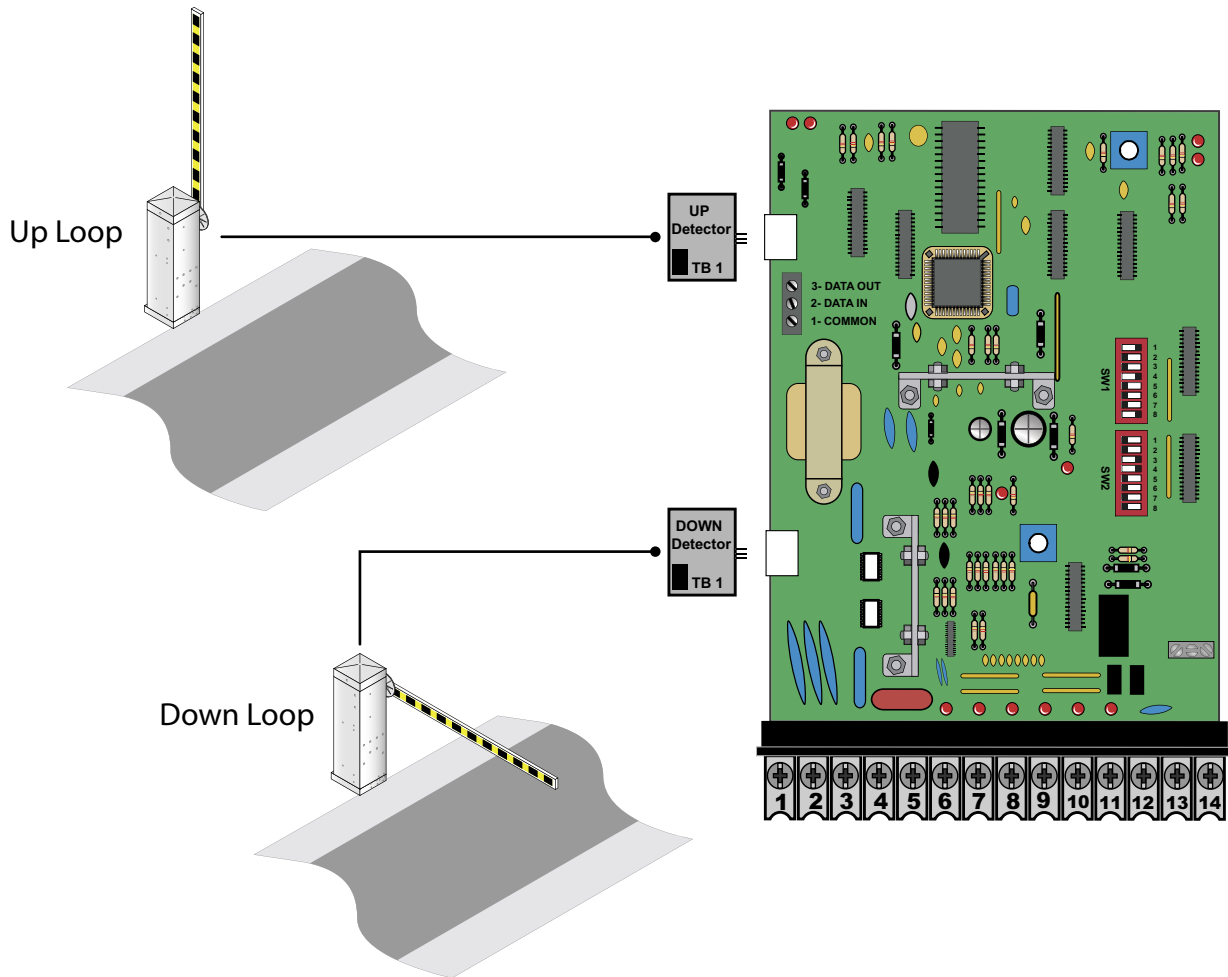

Power must be turned off prior to making any connections to the terminal strip.

If using other loop detectors, inputs to the terminal strip are NORMALLY OPEN.

If using other loop detectors, refer to the separate.

Loop layouts shown are for typical barrier gate applications.

If using other loop detectors refer to the separate Loop Information Manual for installation instructions, loops/preformed loops and wiring diagrams.

electrical installation/entry lane application

- 1 Use a 9405 loop detector plugged into the DOWN port on the 1601 circuit board. Connect the DOWN loop to terminals TB-1 and the ARMING loop to terminals TB-2.
- 2 If the optional arming loop is not used, use a 9406 detector plugged into the DOWN port on the 1601 circuit board and connect the DOWN loop to terminals TB-1 on this detector.
- 3 The timer (SW-1, switch 7) should be OFF. The arm will rotate down after the vehicle clears the down loop.
- 4 SW-1, switch 4 must be ON.

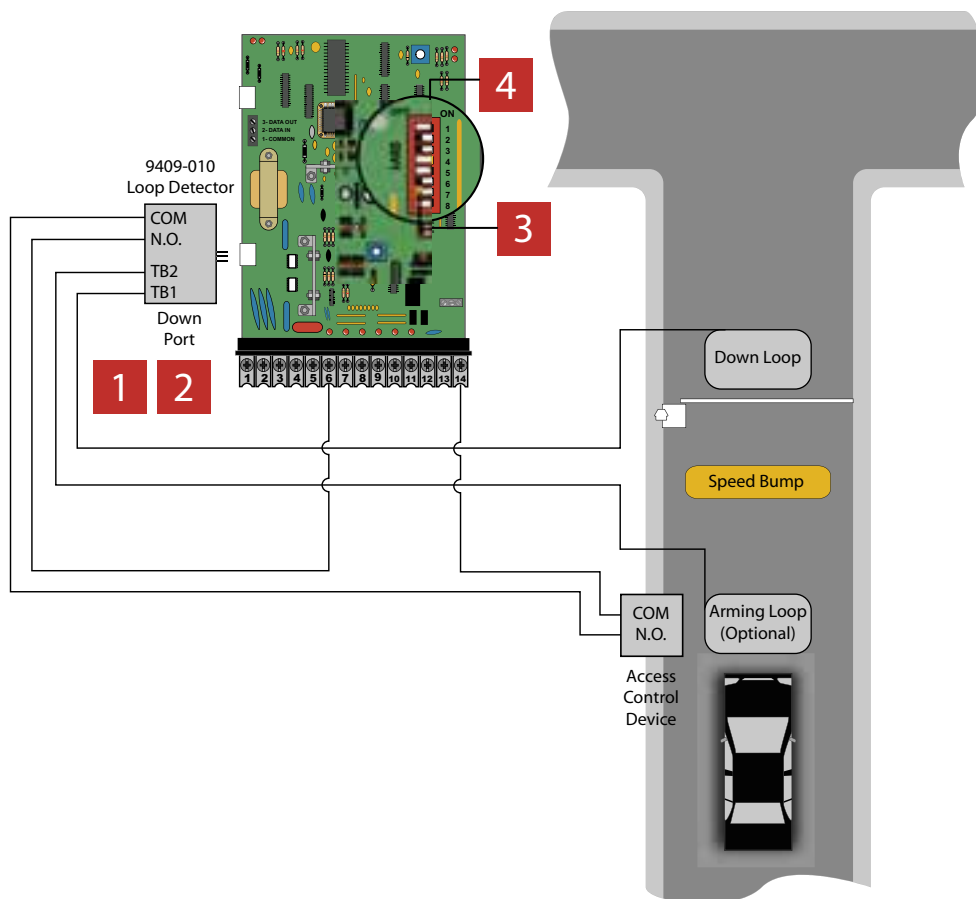

- 1 Use a 9406 detector plugged into the DOWN port on the 1601 circuit board and connect the DOWN loop to terminals TB-1 on this detector.
- 2 Use a second 9406 detector plugged into the UP port on the 1601 circuit board and connect the EXIT loop to terminals TB-1 on the detector.
- 3 The timer (SW-1, switch 7) should be OFF. The arm will rotate down after the vehicle clears the down loop.
- 4 SW-1, switch 4 must be ON.

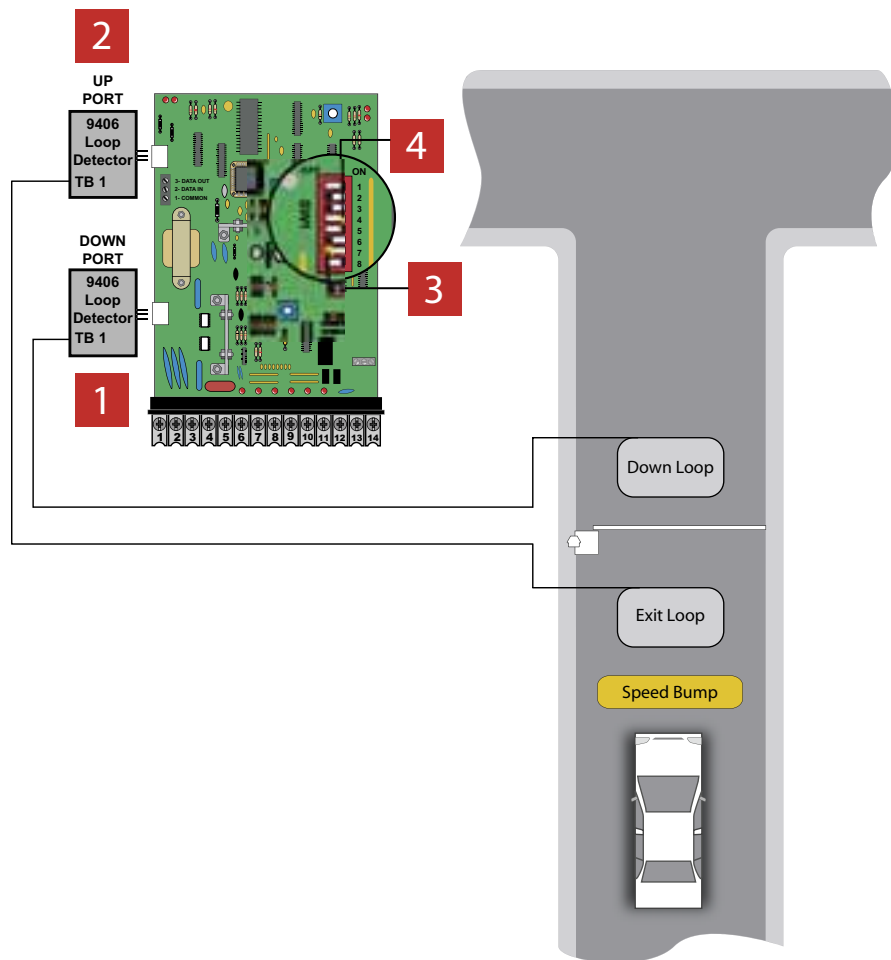

electrical installation/ticket spitter application

- 1** Use a 9405 loop detector plugged into the DOWN port on the 1601 circuit board. Connect the DOWN loop to terminals TB-1 and the TICKET EJECT loop to terminals TB-2.
- 2** The timer (SW-1, switch 7) should be OFF. The arm will rotate down after the vehicle clears the down loop.
- 3** SW-1, switch 4 must be ON.

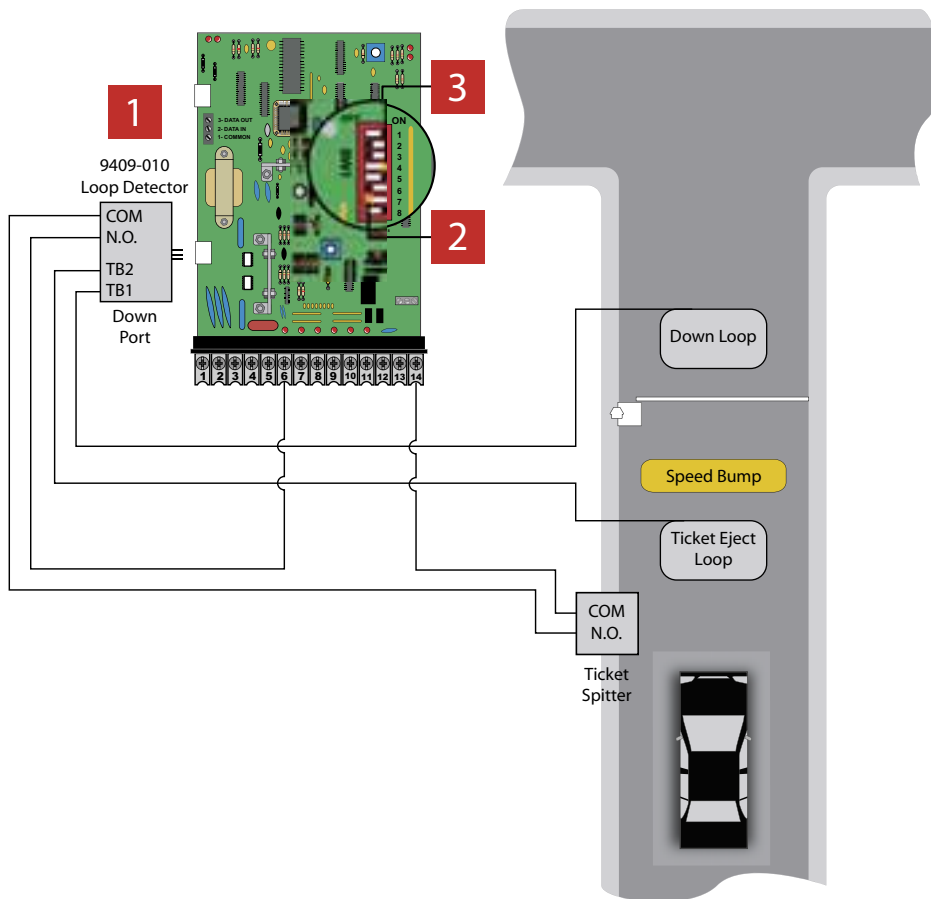

electrical installation/two-way lane application

- 1 Plug a 9406 loop detector into the UP loop port on the 1601 circuit board and connect the EXIT loop to terminals TB-1.
- 2 Use a 9405 loop detector plugged into the DOWN port on the 1601 circuit board. Connect the DOWN loops, wired in series, to terminals TB-1 and the ARMING loop to terminals TB-2.
- 3 If the optional arming loop is not used, use a 9406 detector plugged into the DOWN port on the 1601 circuit board and connect the DOWN loops, wired in series, to terminals TB-1 on this detector.
- 4 The timer (SW-1, switch 7) should be OFF. The arm will rotate down after the vehicle clears the down loops.
- 5 SW-1, switch 4 must be ON.
- 6 Spacing of the loops is critical when using this configuration. Be sure that the loops are spaced as shown in the diagram.

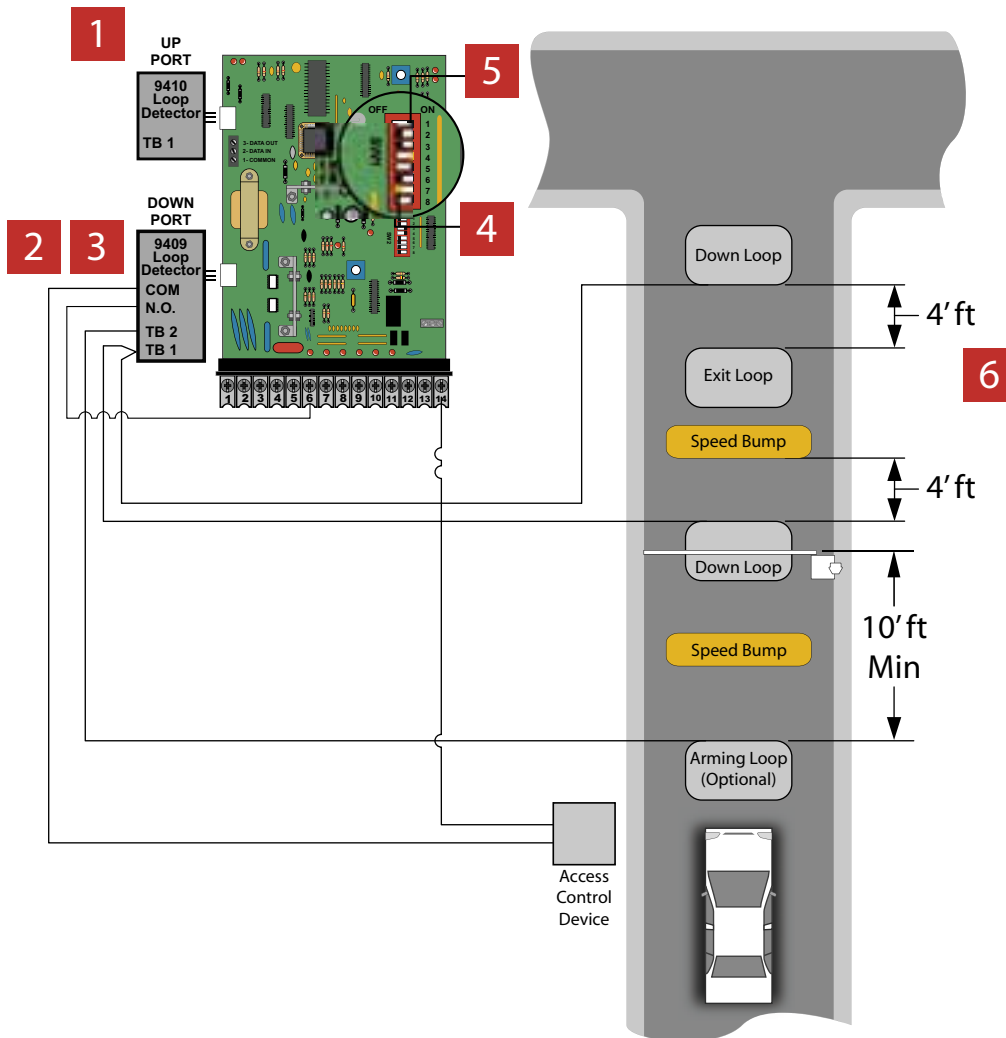

electrical installation/timer down application

- 1 Use a 9405 loop detector plugged into the DOWN port on the 1601 circuit board. Connect the REVERSE loops, wired in series, to terminals TB-1 and the ARMING loop to terminals TB-2.
- 2 If the optional arming loop is not used, use a 9406 detector plugged into the DOWN port on the 1601 circuit board and connect the REVERSE loops, wired in series, to terminals TB-1 on this detector.
- 3 The timer (SW-1, switch 7) should be ON. The arm will rotate down after the vehicle clears the reverse loops and the timer times out.
- 4 SW-1, switch 4 must be OFF.
- 5 Spacing of the loops is critical when using this configuration. Be sure that the loops are spaced as shown in the diagram.

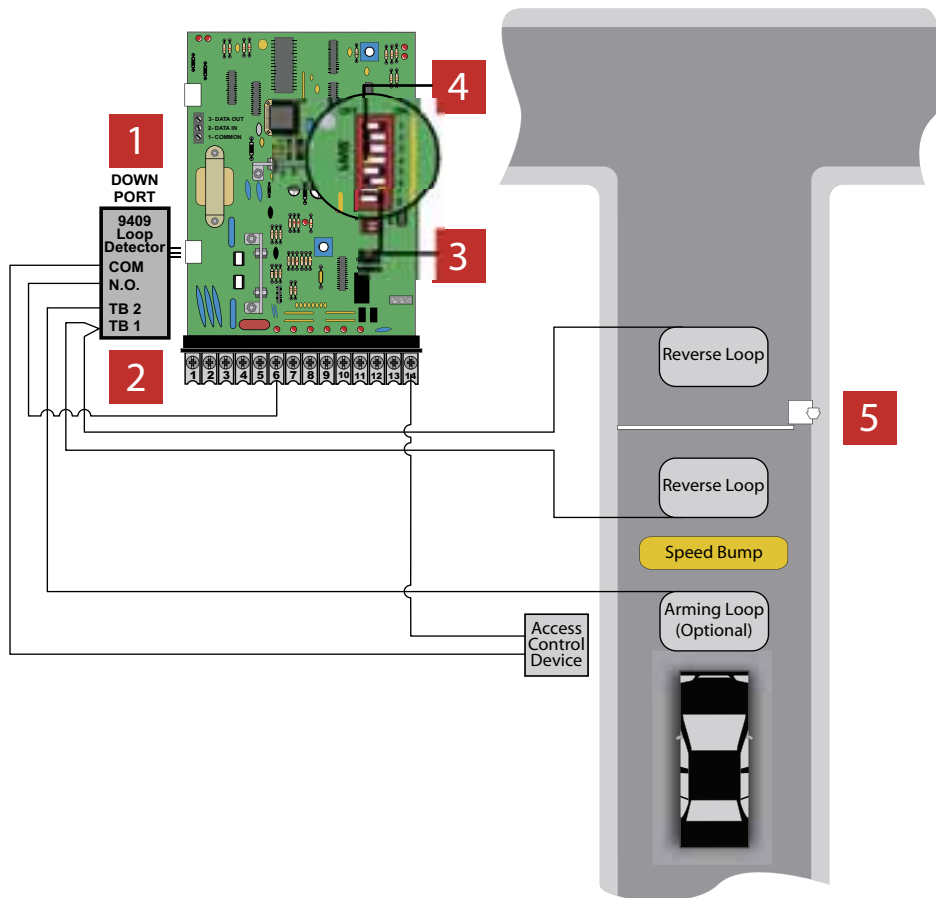

1 Using the supplied hardware install and secure the arm hub as shown.

2 Follow the same instructions when installing an additional mounting hub on the opposite side.

! **Test operator and set the up and down direction before installing arm.**

! **Install the arm hub with the mounting holes in a X pattern when the operator is in the down position.**

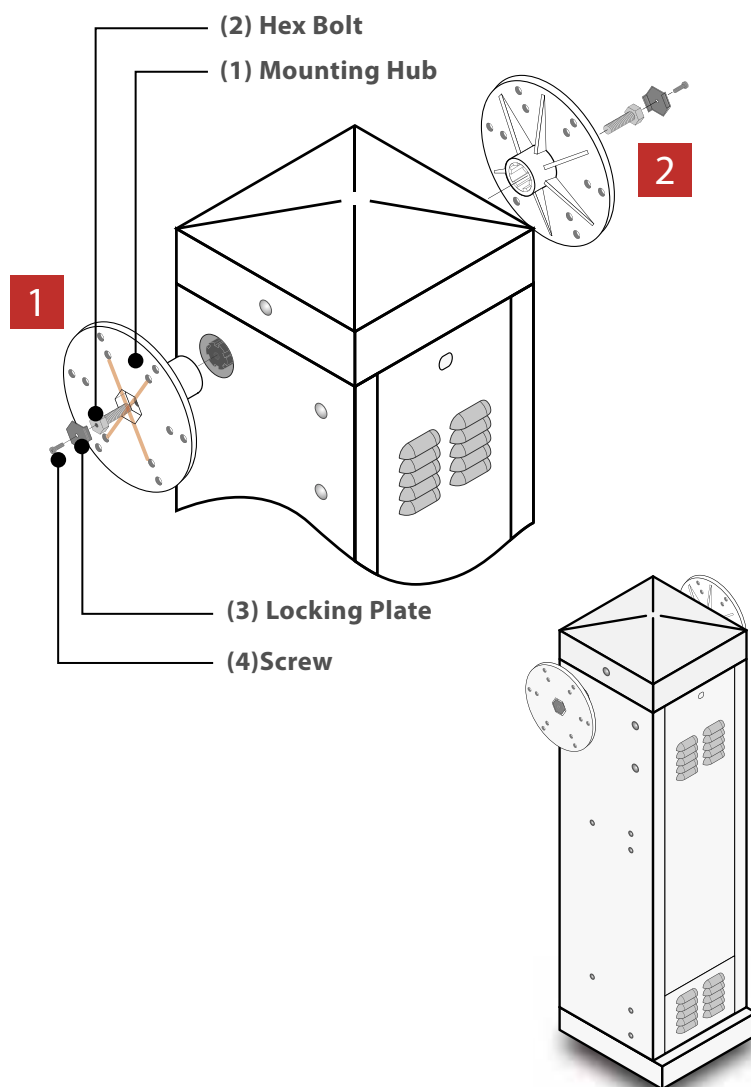

arm installation/aluminum-plastic-wood

- 1 Attach the mounting bracket to the hub using the supplied hardware, **DO NOT TIGHTEN BOLTS.**
- 2 Slide the barrier arm into the mounting bracket.
- 3 Tighten the mounting bracket to the hub as shown.

ALUMINUM

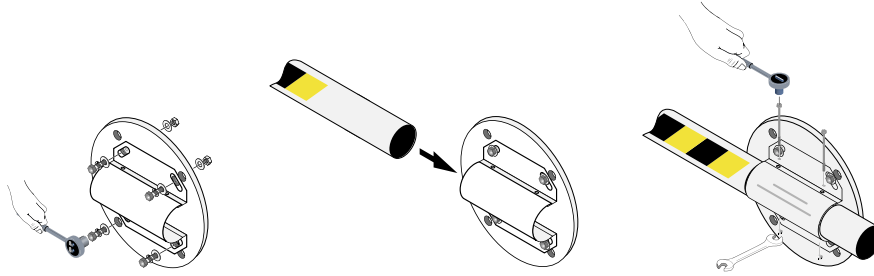

PLASTIC

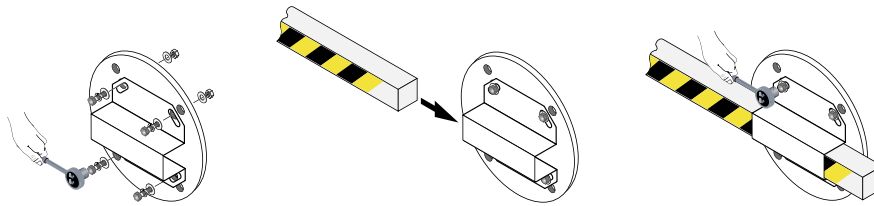

WOOD

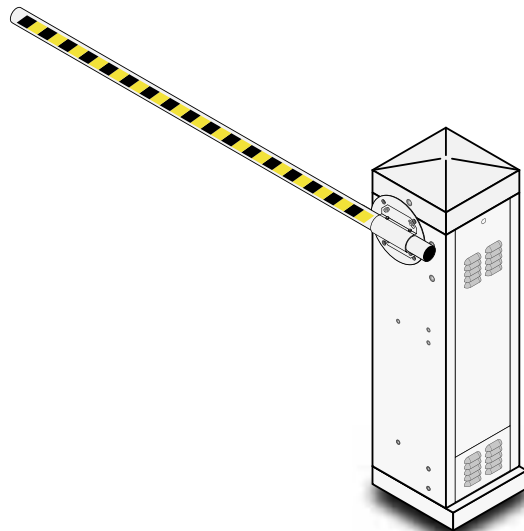
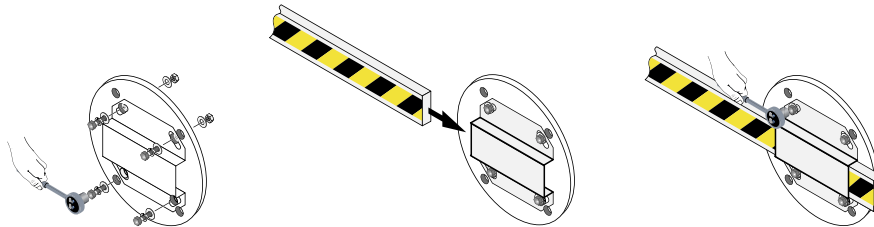

- 1** Install the two (2) barrier arm mounting brackets onto the hubs as shown, do not tighten the bolts at this time. Refer to page 22 for more information.
- 2** Slide the 14'ft. barrier arm through the mounting brackets. The arms must extend at least 14" inches behind the arm hubs allowing the counter balance plates to be installed.
- 3** Tighten and secure the 14' ft. arm to the arm hubs.
- 4** Install the 10'ft. barrier arm between the two 14' ft. arms using the supplied hardware.
- 5** Install the inside/outside counterweight plates on the barrier arms using the supplied hardware.

! Check for correct shaft rotation.
● Refer to page 21 when installing the hubs.

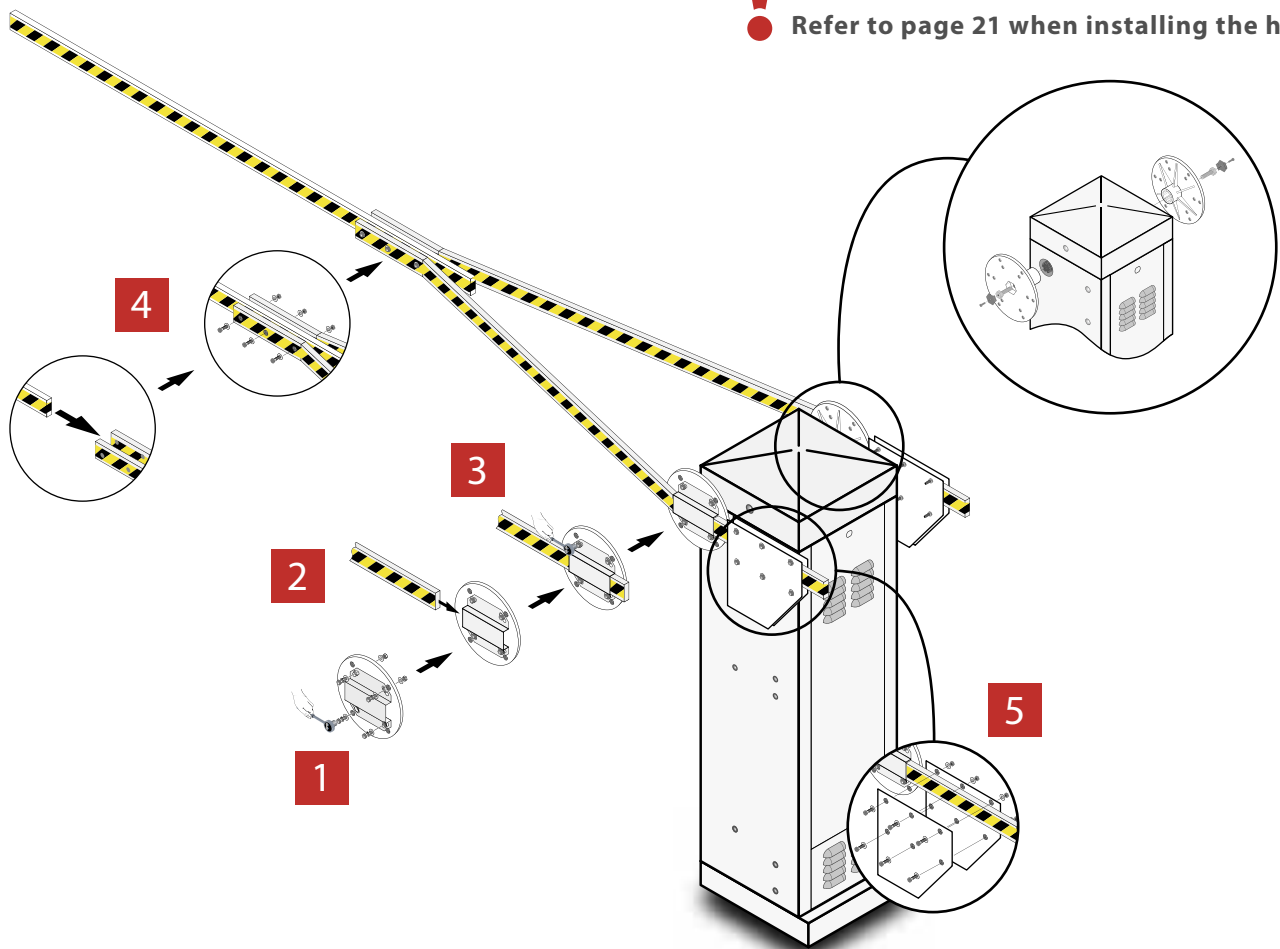

settings/control board

Settings and adjustments should be made after installation and wiring to the operator(s) is complete. Power must be shut-off before programming switches on the circuit board are changed and turned back on for the new setting to take effect.

1. DIP SWITCHES - Turn OFF/ON operating features and modes.

2. AUTO CLOSE TIMER - Adjust from one (1) second to (when set to full counter clock-wise) to approximately 60 seconds (when set to full clock-wise).

3. RELAY 1 CONTACT - (terminals 12-13) can be set for Normally Open (NO) or Normally Closed (NC) operation by placing the relay shorting bar on the NO or NC pins respectively. Relay activation is dependant on setting of SW1, switch 5.

4. ARM RELAY CONTACTS - (C – NC – NO) This relay can be used for a variety of purposes and is typically used to signal when the arm is up or down.

5. POWER LED - Indicates that low voltage power is applied to the circuit board. The input LEDs should be OFF and will only illuminate when the input is activated.

6. LIMIT LED - On when the arm is in the respective position.

7. TRACKER ACTIVITY LED - See page 14. An automatic sensor system that senses entrapment of a solid object and is incorporated as a permanent and integral part of the operator.

8. GATE OPERATOR DATA TERMINAL

- Operator status reporting; cycle count, shorted inputs, loop detector problems, power interruptions, etc.

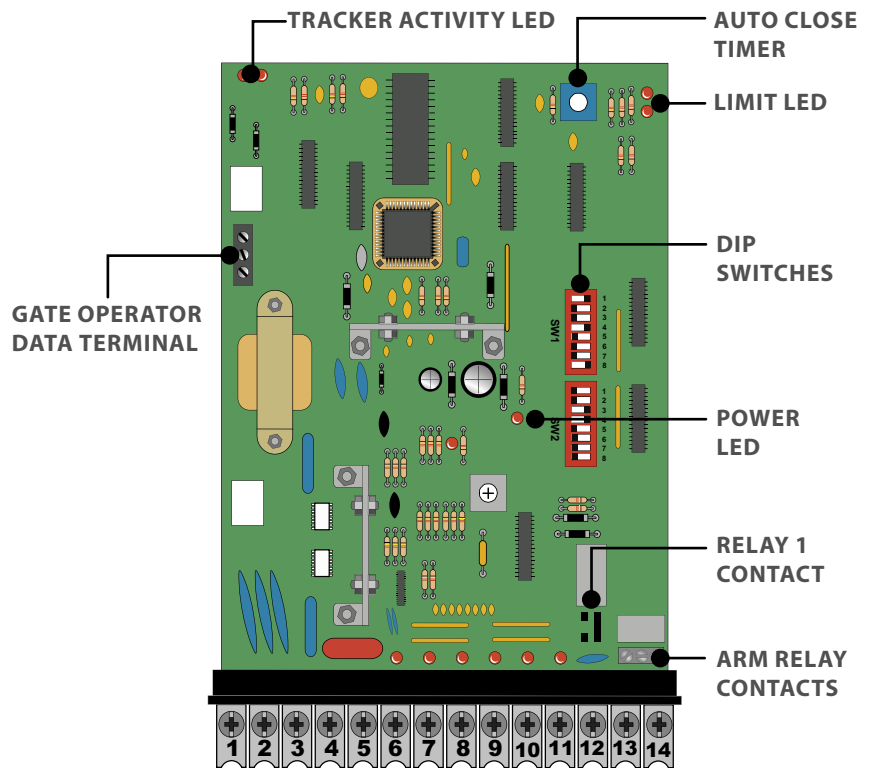

The operator has been preset at the factory to rotate 90° no adjustments are necessary when used in a normal setup. Follow the steps below to adjust the barrier arm rotation.

- 1** Turn the operator power **OFF** at the breaker panel.
- 2** Remove the plastic circuit board cover. Set SW1 DIP-switch 3 to the **ON** position. This changes the rotation of the gearbox from 360° to 180°, and allows the magnetic limits to stop the rotation at less than 180° if necessary, causing the arm to rotate less than 90°.
- 3** Loosen the nuts and adjust the rotation by sliding the magnets, **NOTE: sliding the magnets towards each other shortens the rotation; the maximum rotation of the output shaft is 90°.**
- 4** Tighten the nuts before turning the **ON** the operator at the breaker panel.
- 5** Check the shaft rotation by activating the UP input toggle switch. **NOTE: To prevent possible damage to the operator or barrier arms, remove any obstructions during initial checks.**
- 6** Repeat steps 1 through 5 until the desired rotation is achieved.

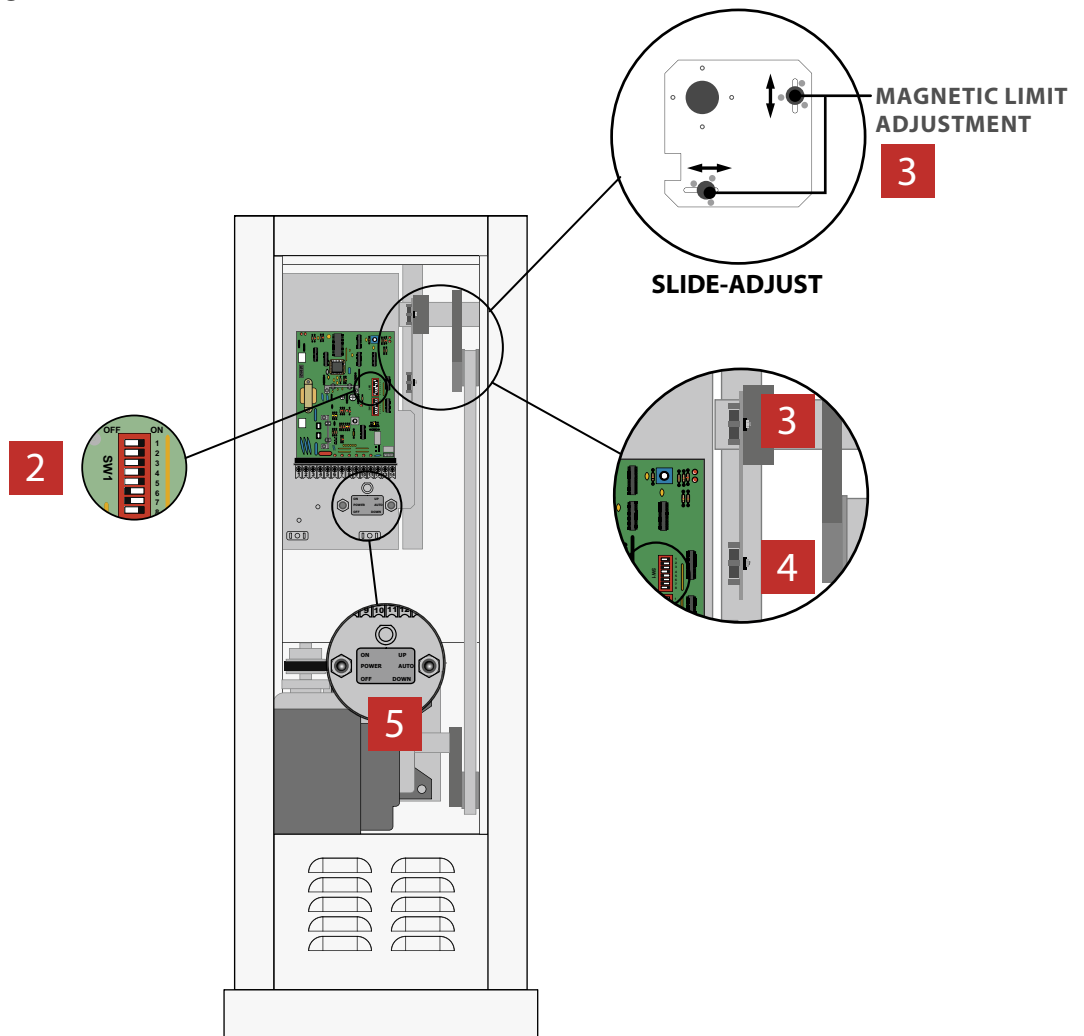

settings/direction check

Before installing the barrier arm the rotation of the output shaft must be checked. The rotation of the arm is dependent on how the operator has been installed (door of the operator opposite the traffic lane, or door of the operator facing the traffic lane), and if the operator has been installed on the left or right hand side of the traffic lane. It is important that the shaft rotation be checked BEFORE installing the arm(s) onto the operator.

NOTE: If the output shaft rotation is in the opposite direction for your application and the arm(s) has been installed prior to checking the rotation direction, damage to both the arm(s) and the operator may result when the operator is placed in service.

- 1** Turn ON the barrier operator and place the control toggle switch to the UP position and check the shaft rotation; continue to step 2 if rotation is incorrect.
- 2** Turn the operator power OFF at the breaker panel.
- 3** Remove the plastic circuit board cover.
- 4** Loosen the magnet nut; each magnet has a marking on one side.
 - 4a** Check the magnet and flip to the opposite side.
 - 4b** Manually turn the drive pulley to access the other magnet.
 - 4c** Check the magnet and flip to the opposite side.
 - 4d** One magnet must have the marking facing out and one magnet must have the marking facing in.
- 5** Reinstall the plastic circuit board cover and repeat step 1 to check rotation.

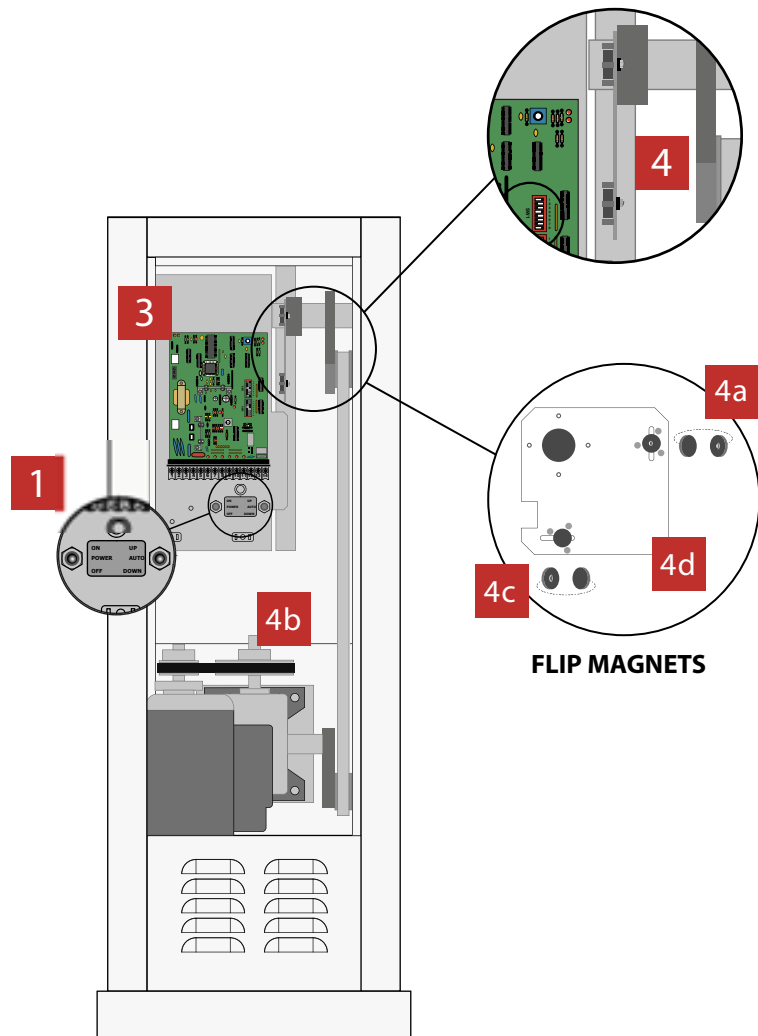

Reverse sensitivity adjustment will cause the barrier arm to reverse direction of travel should an object be encountered during the down cycle. The amount of force required for the arm to reverse direction depends on the reverse sensitivity potentiometer.

- 1** Set the AC power switch to the ON position.
- 2** Set the control switch to the UP position, the arm should rotate UP.
- 3** Set control switch to the DOWN position, the arm will rotate down. **CAUTION:** Keep pedestrians and vehicles clear of the arm zone!
- 4** While the arm is traveling down, rotate the reverse potentiometer clockwise until the reverse LED illuminates, the arm will reverse travel at this time.
- 5** Rotate the reverse potentiometer counter clockwise 1/8
- 6** Repeat the adjustment as needed to find a satisfactory setting.

! The ERD (electronic reversing device) in the operator is not intended to replace external reversing devices such as loops, photo electric eyes, or reversing edges. It is important that these devices be installed according to the needs and requirements of your particular application.

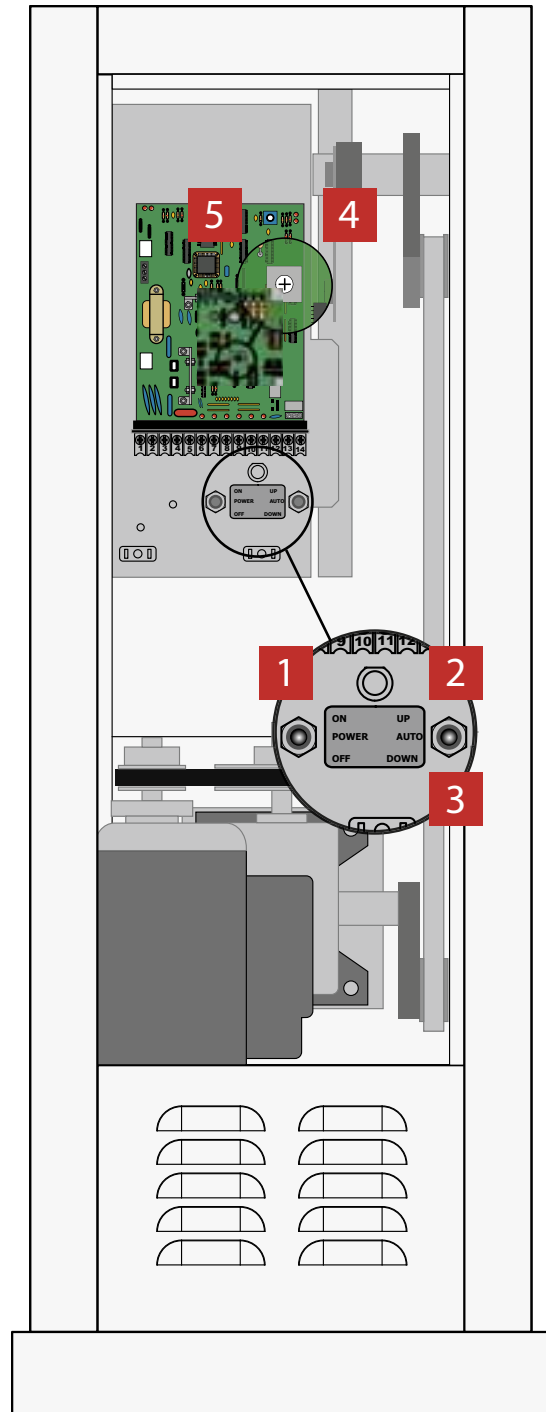

settings/switch descriptions & functions

The DIP-switches located on the circuit board are used to set operating modes and to turn ON or OFF various operating features. SW1 is the top switch, SW2 is the BOTTOM. When a switch setting is changed, power to the operator must be turned OFF, and turned back on for the setting to take affect. Check and review ALL switch settings prior to applying power to the operator.

SW1 (top switch)	Switch	Function	Setting	Description
	1	Down Active when arm is full up	OFF	Activation and then deactivation of the down loop or down / reverse input will cause the arm to rotate down ONLY if the deactivation occurred after the arm reached the FULL UP position.
		Down Active when arm is moving up or is up	ON	Activation and then deactivation of the down loop or down / reverse input will cause the arm to rotate down AFTER reaching the FULL UP position regardless of when the deactivation occurred.
	2	Self Test	OFF	Normal setting. Self-test is turned off.
			ON	Runs self test.
	3	Gear Box Travel	OFF	Normal setting. Operator uses 360° of gearbox.
			ON	Alternate setting. Operator uses 180° of gearbox.
	4	Down / Reverse Loop and Input	OFF	Down / Reverse loop and input will function as a REVERSE loop and REVERSE input.
			ON	Normal setting. Down / Reverse loop and input will function as a down input and cause the arm to rotate down upon deactivation of the input. See SW 1, switch 1 for additional information.
5	Relay 1 Activation	OFF	Normal setting. Relay activates when the DOWN loop detector (DoorKing plug-in detector only) senses a vehicle presence.	
		ON	Relay activates when the UP loop detector (DoorKing plug-in detector only) senses a vehicle presence.	
6	Up Input Function	OFF	Up Input will raise arm and/or reset the down timer. Input will not lower the arm.	
		ON	Up Input will raise arm if it is down, or will lower arm if it is up.	
7	Time Delay	OFF	Time delay to lower arm is OFF.	
		ON	Time delay to lower arm is ON.	
8	UP Loop Port Output	OFF	Output of the loop detector plugged into the UP loop port is switched to terminal 7 for connection to other input terminals.	
		ON	Normal setting. Output of the loop detector plugged into the UP loop port will raise arm when activated.	

SW2 (bottom switch)	Switch	Function	Setting	Description
	1	Operator Model	OFF	Switch must be set OFF for model 1603 operators.
	2	Multiple Input Memory	OFF	Normal Operation. Operator will respond to most recent command. If multiple UP inputs are received, the NEXT down command will lower arm.
			ON	Remember multiple inputs. SW 1, switch 4 must also be on.
	3	Multiple Input Memory Options	OFF	Second Car Down – If a vehicle is on the down loop when the 1601 receives another UP command, the operator will ignore the close command when the first vehicle clears the down loop and will require the second vehicle to clear the down loop to lower the arm.
			ON	Multiple Up Commands – The 1601 will count the number of UP commands it receives and will require a matching number of down commands to lower the arm whether or not down loop is active.
	4	Stop Loop Function	OFF	Normal Operation. The down loop is inactive DURING the down cycle.
			ON	Stop Loop – If a vehicle activates the down loop during the down cycle, the arm will STOP. An UP command will raise the arm, or the arm will continue down AFTER the loop is cleared.
	5	Reverse Delay	ON	Instant Reverse – Arm reversal is delayed approximately .1 second when a reverse input (terminal 9) is received during the down cycle.
6	Direction	OFF	Changes direction of arm rotation.	
7	Spare	OFF	No Function. Leave in OFF position.	
8	Spare	OFF	No Function. Leave in OFF position.	

accessory installation/reversing edge

In addition to the electronic reversing device (ERD) an optional electric reversing edge (p/n 8080-016) maybe installed offering additional protection to the arm, operator and obstruction.

- 1 Turn operator power **OFF** and center and secure the 6-foot mounting channel to the bottom of the barrier arm using 3/4-inch wood screws (not supplied).
- 2 Slide the reversing edge into the mounting channel as shown.
- 3 Drill a 1/4-inch hole on the side of the operator cabinet beneath the operator shaft and install a grommet to protect the lead-in wire from any sharp metal edges.
- 4 Using wire ties (not supplied) secure the lead-in wire along the side of the arm; leave a loop allowing the arm to rotate without obstruction.
- 5 Route the lead-in wire through the hole and connect to terminals 9 and 14 without interfering with any moving parts.

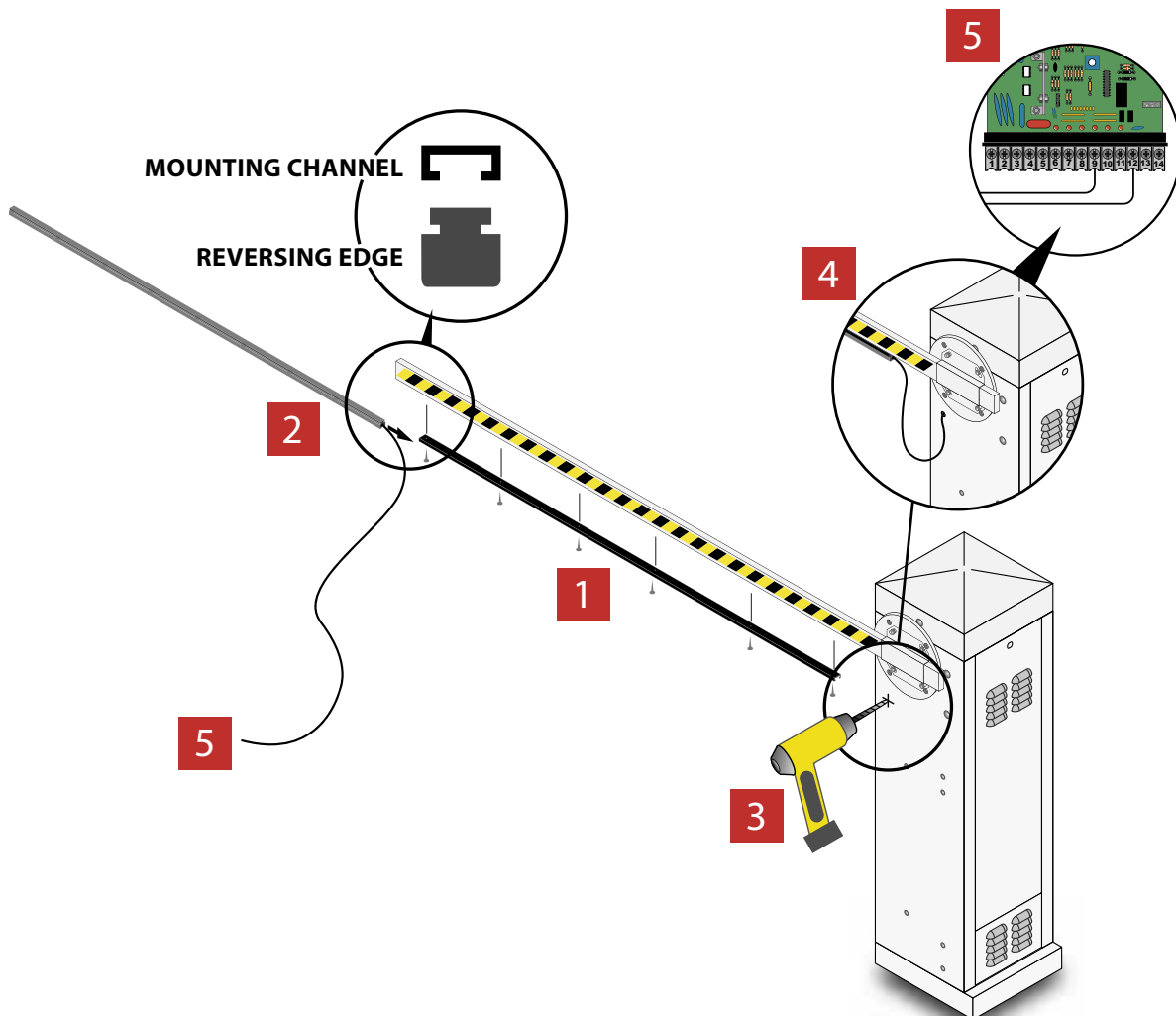

accessory installation/fan kit

An optional fan kit is recommended in hot humid climates to prevent moisture build-up inside the cabinet.

- 1** Turn the operator power OFF at the circuit breaker panel; all connections will be made to the high voltage terminal strip.
- 2** Install the fan on the lower right side of the cabinet and duct using the pre-existing mounting screws.
- 3** Route the wiring through the side of the access door as shown. Use the supplied hardware to secure the wire assembly. Be sure that the wire assembly is clear of all moving parts.
- 4** Connect the BLACK wire to the 117 VAC terminal on the high voltage terminal block. Connect the WHITE wire to the NEUT terminal.

REAR VIEW

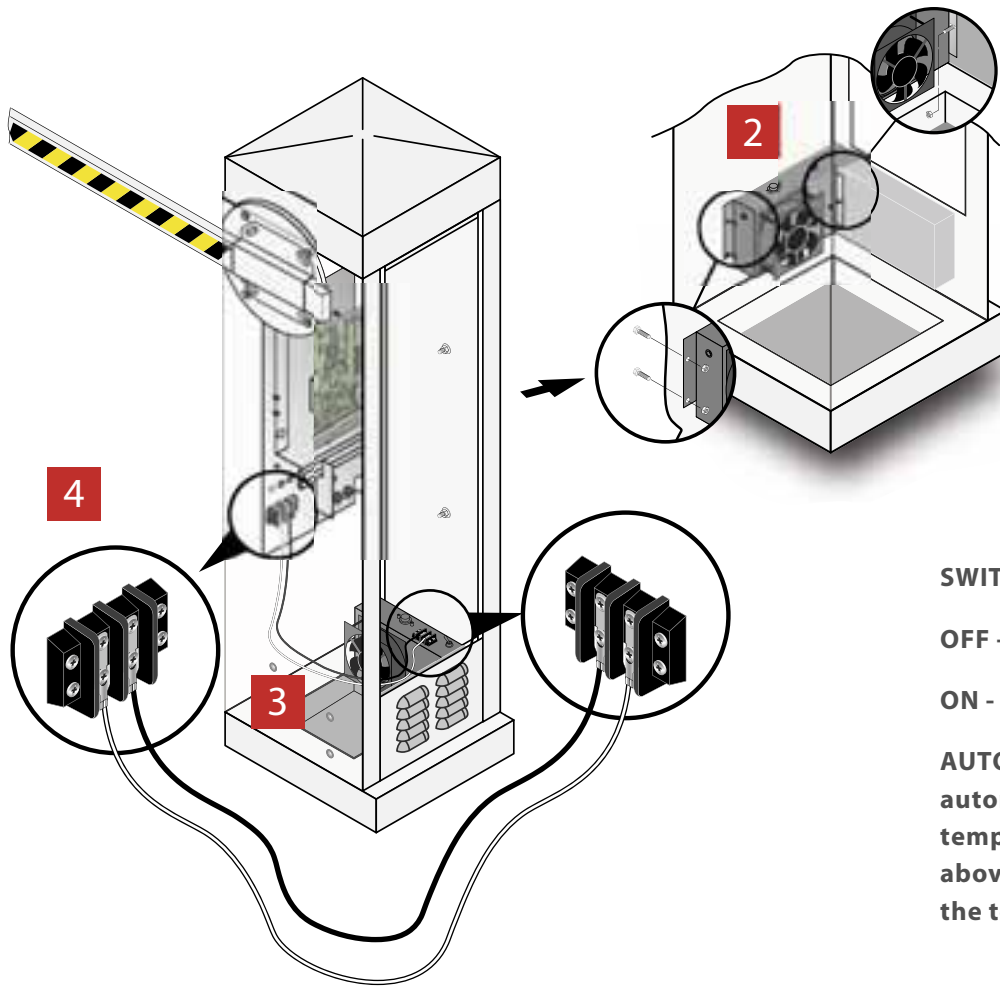

SWITCH SETTING

OFF - Turns the fan off.

ON - Turns the fan on continuously.

AUTO - Normal setting. The fan will automatically turn on when the temperature inside the cabinet rises above 90°F, and will turn off when the temperature drops below 90°F.

To avoid the gearbox oil from freezing an optional heater kit is recommended in areas where temperatures routinely drop below 40°F (4°C).

- 1** Turn the operator power OFF at the circuit breaker panel; all connections will be made to the high voltage terminal strip.
- 2** Install the heater on the right side of cabinet using the pre-existing mounting screws. NOTE: Place #10 washers on the mounting screws before placing the heater assembly on the screws. Place #10 between the cabinet and the heater assembly.
- 3** Route the wiring through the side of the access door as shown. Use the supplied hardware to secure the wire assembly. Be sure that the wire assembly is clear of all moving parts.
- 4** Connect the BLACK wire to the 117 VAC terminal on the high voltage terminal block. Connect the WHITE wire to the NEUT terminal.

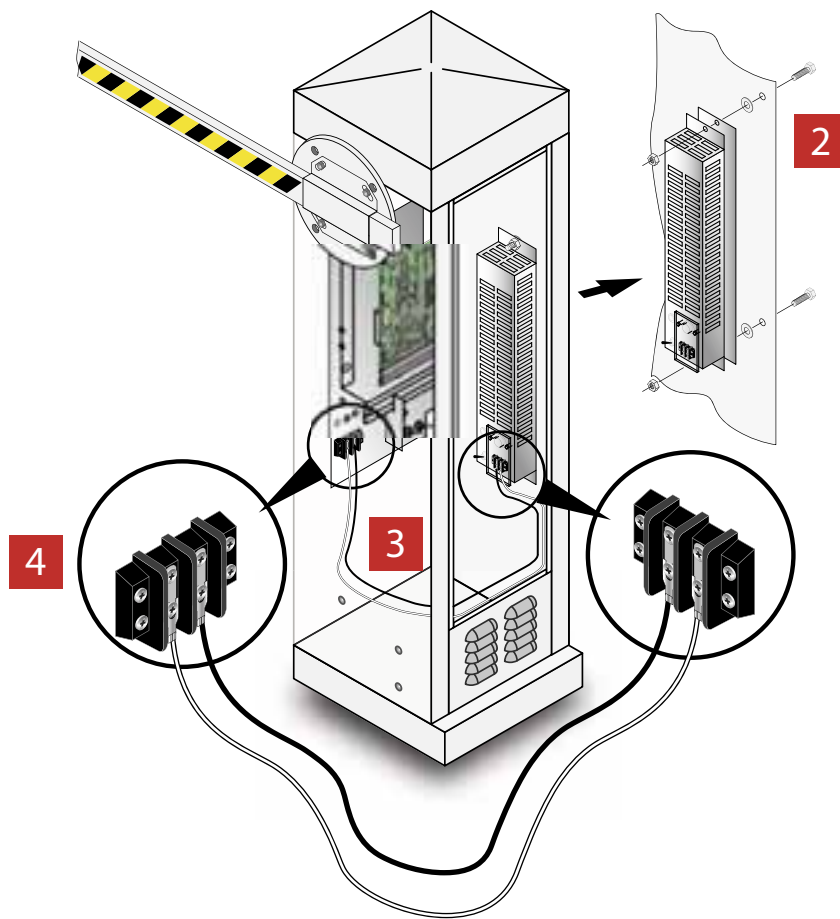

SWITCH SETTING

OFF - Turns the heater off.

ON - Turns the heater on continuously. Use with caution since the heater can become very hot when running continuously.

AUTO - Normal setting. The heater will automatically turn on when the temperature inside the cabinet falls below 40°F, and will turn off when the temperature rises above 40°F.

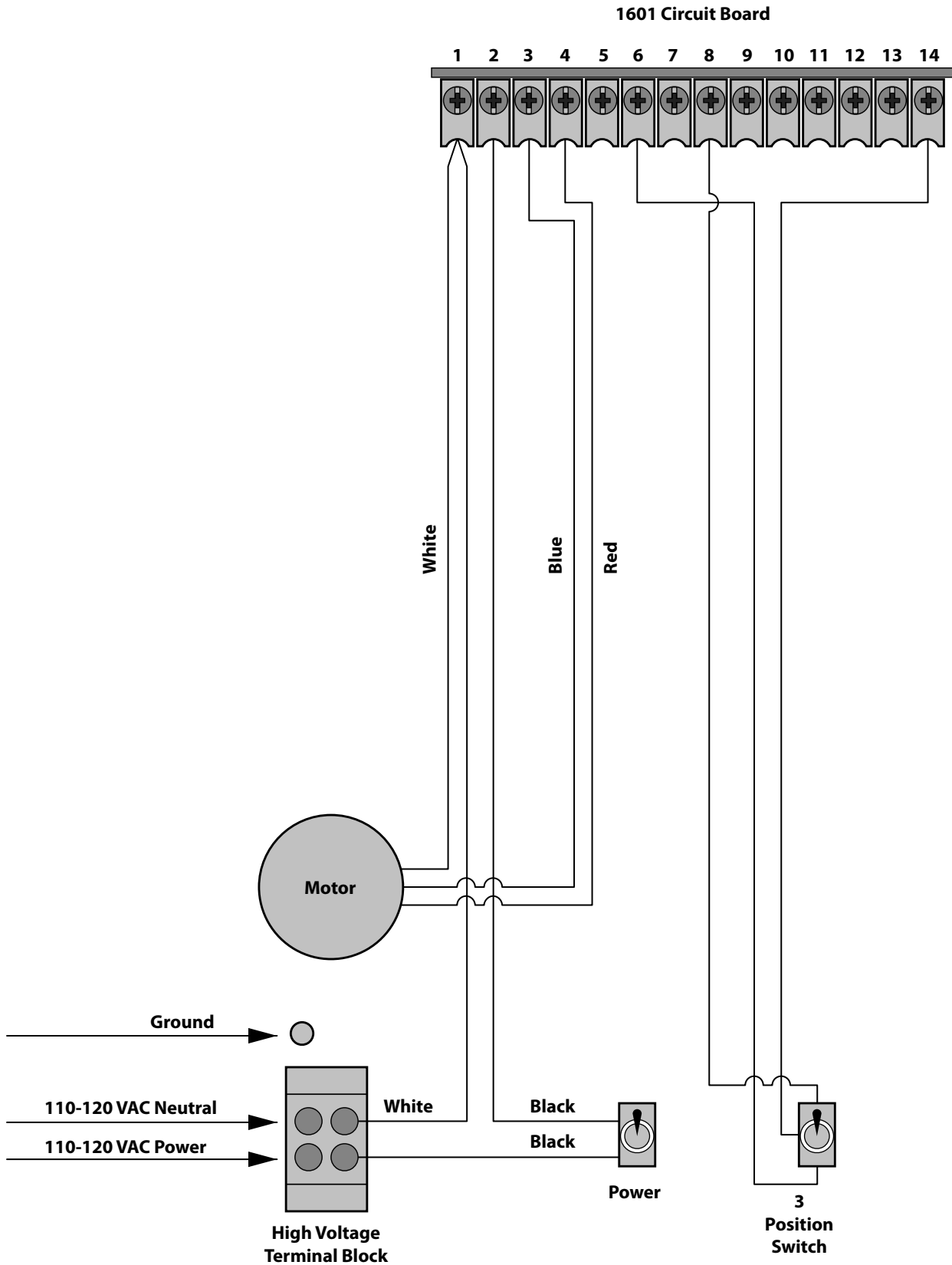

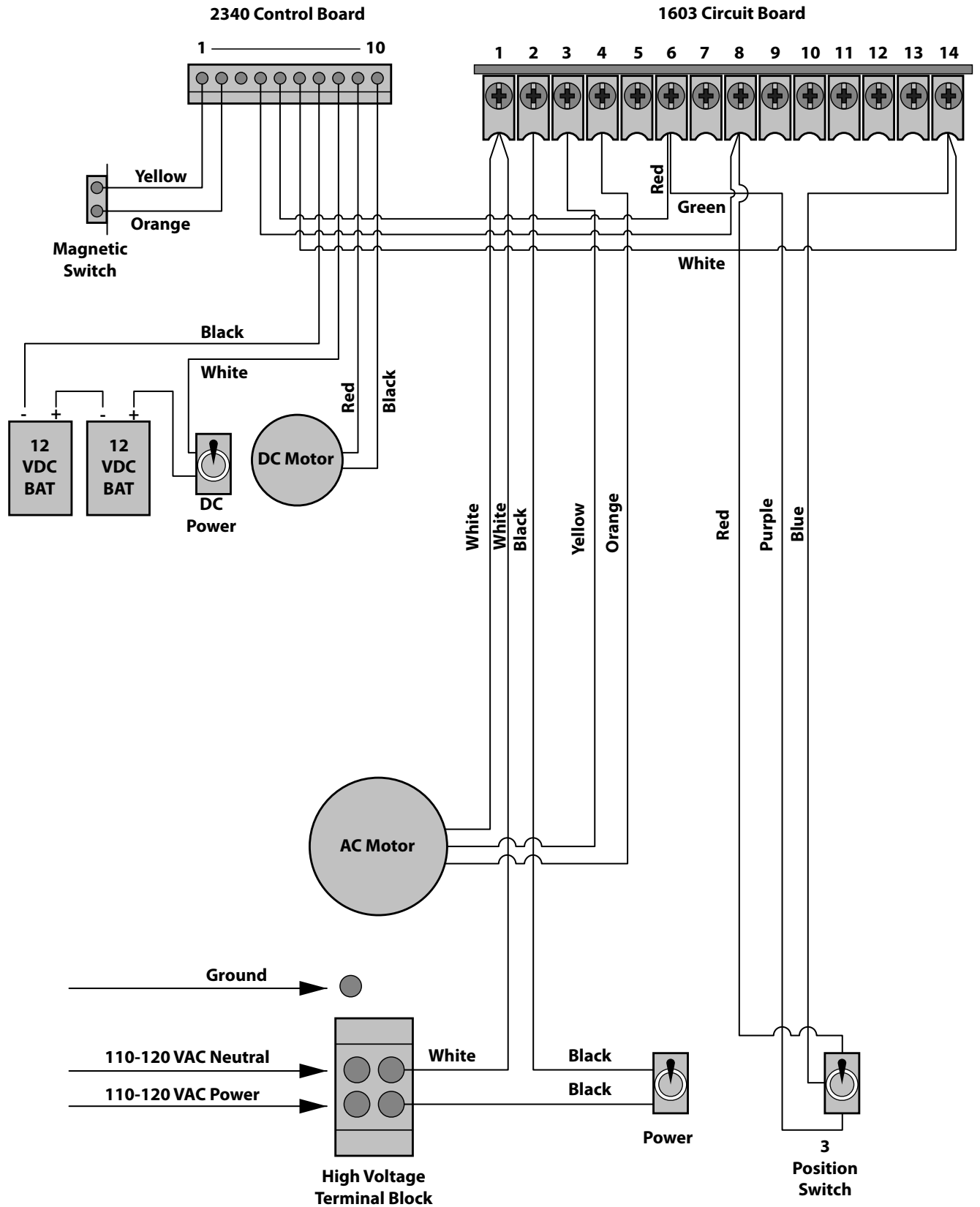

technical information/maintenance schedule

Component	Maintenance Description	3 month	6 month	12 month
Arm	Check for alignment, tightness and wear.		✓	✓
Belt	Check for alignment, tightness and wear.		✓	✓
ERD	Check the electronic reversing device for proper operation. Adjust sensitivity if necessary.	✓		✓
Fire Dept.	Check emergency vehicle access device(s) for proper operation.	✓		✓
Gearbox	Check oil level.			✓
Linkages	Check internal linkages for wear. Inspect bushing for wear.		✓	✓
Loops	Check all external ground loops for proper operation.	✓		✓
Pulleys	Check set-screws for tightness.		✓	✓
Reversing Devices	Check electric edges and photo-cells for proper operation.	✓		✓
Complete Check	Perform a complete system check. Include all reversing devices, loops, access system devices, Fire Dept. access devices, etc.			✓



- **When servicing, turn the AC power switch to the OFF position. If equipped with a battery back-up switch to the OFF position.**
- **Inspection and service should be performed when a malfunction is observed or suspected. High cycle usage may require more frequent service checks.**
- **Use only Shell OMALA 150 gear oil when adding or replacing gearbox oil. IMPORTANT: Do not fill gearbox to top. Gearbox is full when oil completely covers inspection window.**
- **Check external reversing devices (loops, photo-cells, etc.) when performing maintenance. If reversing devices are not functional and cannot be placed in an operable state, DO NOT PLACE OPERATOR IN SERVICE. If the operator is equipped with a battery back-up system, follow the steps below to check the operation of this system.**
 1. **Prior to checking the battery back-up system, both the AC power switch and the battery back-up switch should be in the ON position.**
 2. **Place the AC power switch to the OFF position. The arm should rotate to the UP position approximately two seconds after the AC power switch is shut off.**
 3. **Turn the AC power switch to the ON position. The operator will resume normal operation.**

Condition	Possible Solution
Operator will not run – power LED on control board is OFF.	<ul style="list-style-type: none"> • Be sure AC power switch is on. • Check for 117 VAC with a voltmeter at control board terminals 1 and 2. If voltage measures 0, check power supply to operator or check terminal strip. If voltage measures OK, replace control board.
Operator will not run – power LED on control board is ON.	<ul style="list-style-type: none"> • Momentarily jumper terminal 6 to terminal 14. If input LED does not come ON, check terminal strip or replace control board. If LED does come on, go to the next step. • Momentarily jumper terminal 2 to terminal 3 (Caution – High Voltage). The motor should run. • Momentarily jumper terminal 2 to terminal 4 (Caution – High Voltage). The motor should run in opposite direction of above. • If motor does not run in either or both steps above, bad motor, motor capacitor or wiring to motor.
Arm rotates up, but will not rotate down.	<ul style="list-style-type: none"> • Check LEDs on terminals 6, 7 and 9. Any of these ON will hold the arm in the UP position. This indicates a shorted input. • Check the LEDs on the loop detectors. Any ON will hold the arm in the UP position. Possible loop or loop detector problem. • If auto timer is not used (SW1, switch 7 off), check to be sure SW1, switch 6 is in the ON position. This will cause terminal 6 to rotate the arm down when it is activated. • Check to be sure SW1, switch 4 is ON. This will cause terminal 8 activation, then deactivation to rotate arm down.
Down input / down loop will not rotate arm to down position.	<ul style="list-style-type: none"> • Check to be sure SW1, switch 4 is in the ON position. • Down input must be activated, and then deactivated to cause arm to rotate down.
Loop detector LED is on continuously.	<ul style="list-style-type: none"> • Activate the reset switch on the loop detector. • Decrease loop detector sensitivity. • Check loop wire for resistance to ground with meg-ohm meter. Should be 100 meg-ohms or higher. If less than 50 meg-ohms, replace loop wire. • Be sure loop lead-in wire is twisted at least 6 turns per foot. • Be sure all loop connections are soldered. • Replace loop detector.
Loop detector LED never activates.	<ul style="list-style-type: none"> • Increase loop detector sensitivity. • Check continuity of loop wire. Should be 0 ohms. If continuity check indicates anything other than 0 ohms, check all connections. Replace loop wire. • Move loop detector board to the other loop detector port on the control board, and then check loop operation. If loop detector still fails, replace loop board. • If loop detector operates OK in the other loop port, replace control board.
Battery back-up system will not raise arm upon power outage.	<ul style="list-style-type: none"> • Check to be sure that the 2340-010 battery back-up control board switch settings are set as described in section 2.x. • Check that the back-up system toggle switch is in the ON position. • Check the batteries for proper voltage, replace if necessary. • Replace the 2340-010 control board.

Have the following diagnostic tools available: VOM meter with minimum voltage memory or min-max range to check voltage and continuity. Meg-ohm meter capable of checking up to 500 meg-ohms of resistance to properly check ground loop integrity. A malfunction can be isolated to one of the following:

- Gate Operator
- Loop System
- Keying Devices

Use caution when checking high voltage areas: terminals 1 through 6, the motor capacitor and the motor.

Check the input indicator LEDs. They should only come ON when a keying device (card reader, push button, etc.) is activated. If any of the input LEDs are ON continuously, this will cause the operator to hold the arm up. Disconnect the keying devices one at a time until the LED goes OFF.

A malfunction in a loop or loop detector can cause the gate operator to hold open, or not detect a vehicle when it is present over the loop. Pull the loop detector circuit boards from the loop ports on the operator circuit board. If the malfunction persists, the problem is not with the loop system. For more information refer to the loop detector instruction sheet and the DoorKing Loop and Loop Detector Information Manual.

Check to be sure that there are no shorted or open control wires from the keying devices to the gate operator. If a keying device fails to raise the arm, momentarily jumper across terminals 6 and 14 on the operator circuit board. If the arm rises, this indicates that a problem exist with the keying device and is not with the operator.

Check the high voltage supply. A voltage drop on the supply line (usually caused by using too small supply voltage wires) will cause the operator to malfunction. Refer to the wire size chart on page 10.

technical information/accessories

The following accessories are available for 1601 operators.

Loop Detector/plug directly into ports on circuit board simplifying wiring.

P/N 9406-010 - Single channel detector.

P/N 9405-010 - Two channel detector.

Loop Wire/with XLPE insulation is available in 500 and 1000 foot rolls, available in Black, Blue and Red insulation.

Loop Sealant

P/N 2600-771 Asphalt

P/N 2600-772 Concrete

Meg Ohm Meter/checks the integrity of ground loops.

P/N 9401-045

Reverse Edge/installs on the bottom of the wood arm.

P/N 8080-016

Photo Cell/prevents arm from lowering on vehicles or pedestrians.

P/N 8080-018

Time Clock/7 and 365 day clocks, used to automatically open gate at pre-set time, fits inside operator.

P/N 2600-791 7 day clock

P/N 2600-795 365 day clock

Surge Devices/helps prevent circuit board failure caused by lightning strikes and power surges.

P/N 1876-010 - High Voltage

P/N 1878-010 - Low Voltage

Replacement Batteries/back-up system.

P/N 1801-009

Speed Bumps/prefabricated 6-foot speed bump reduces traffic speed through gate system.

P/N 1610-150

Heater Kit/thermostatically controlled heater for cold weather areas.

P/N 1601-092

Fan Kit/thermostatically controlled fan for hot humid environments.

P/N 1601-093

Gate Tracker™/optional control board allows the barrier gate operator to report activity to a companion 1833, 1835, 1837 or 1838 access control system.

Wood Arm/14-foot replacement wood arm.

P/N 1601-048

Aluminum Arm/14-foot replacement aluminum arm.

P/N 1601-216

Arm Padding/foam padding for the aluminum or wood arm.

P/N 1601-211

Shaft Spacer/used when attaching additional spike assemblies.

P/N 1601-069



Designed by DKS, DoorKing in California

DKS DoorKing, Inc



1 6 0 1 - 0 6 5 - M - 0 5 - 0 7