

3-PIECE OCTAGON ARM WITH LED/REVERSE EDGE KIT INSTALL

These LED/Reverse Edge kits are designed **ONLY** for the 1602 model barrier gate operator.

IMPORTANT NOTE: Installation of arms without LED/Reverse Edge kit see pages 7-9.

DoorKing Part Numbers:

1602-282

20 ft Arm Only

AND

1602-292

20 ft LED/Reverse Edge Kit
(Optional for 1602-282 Arm)

1602-284

24 ft Arm Only

AND

1602-294

24 ft LED/Reverse Edge Kit
(Optional for 1602-284 Arm)

1602-287

27 ft Arm Only

AND

1602-297

27 ft LED/Reverse Edge Kit
(Optional for 1602-287 Arm)

Overview of Installation

Prior to beginning the installation of the 3-piece arms **WITH** LED/Reverse edge kit, see pages 1-6. We suggest that you become familiar with the instructions, illustrations, and wiring guide-lines on these pages.

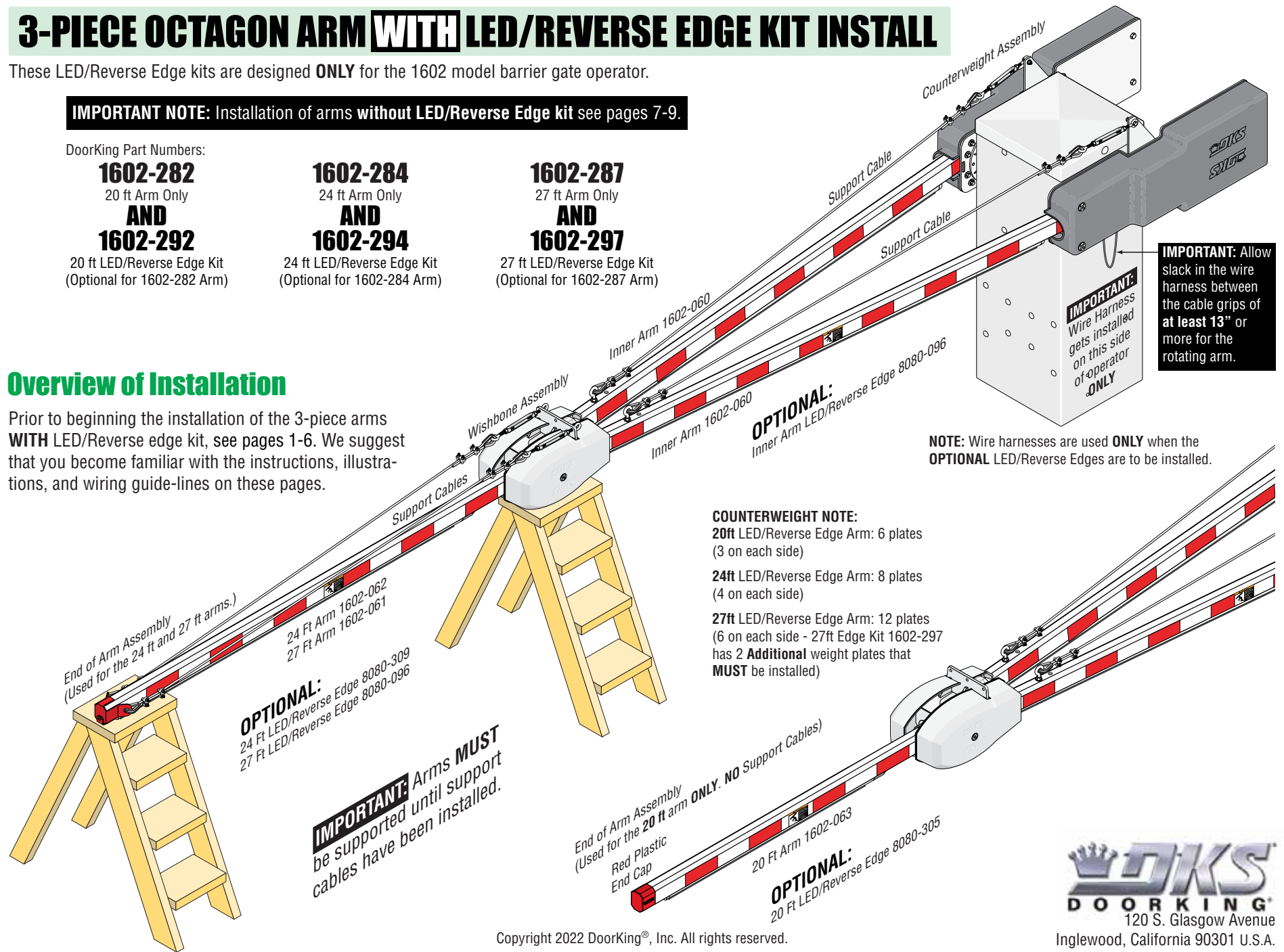

IMPORTANT: Allow slack in the wire harness between the cable grips of **at least 13"** or more for the rotating arm.

IMPORTANT: Wire Harness gets installed on this side of operator **ONLY**

NOTE: Wire harnesses are used **ONLY** when the **OPTIONAL** LED/Reverse Edges are to be installed.

COUNTERWEIGHT NOTE:
20ft LED/Reverse Edge Arm: 6 plates (3 on each side)
24ft LED/Reverse Edge Arm: 8 plates (4 on each side)
27ft LED/Reverse Edge Arm: 12 plates (6 on each side - 27ft Edge Kit 1602-297 has 2 **Additional** weight plates that **MUST** be installed)

IMPORTANT: Arms **MUST** be supported until support cables have been installed.

End of Arm Assembly (Used for the 20 ft arm **ONLY**. NO Support Cables)
 Red Plastic End Cap
OPTIONAL:
 20 Ft Arm 1602-063
 20 Ft LED/Reverse Edge 8080-305



Copyright 2022 DoorKing®, Inc. All rights reserved.

Counterweight Assembly

Mount hubs on operator **FIRST** Test hubs **UP** and **DOWN** positions **BEFORE** installing counterweight mounting plates, then assemble arms, cables and wire harness on LED/Reverse Edge models.

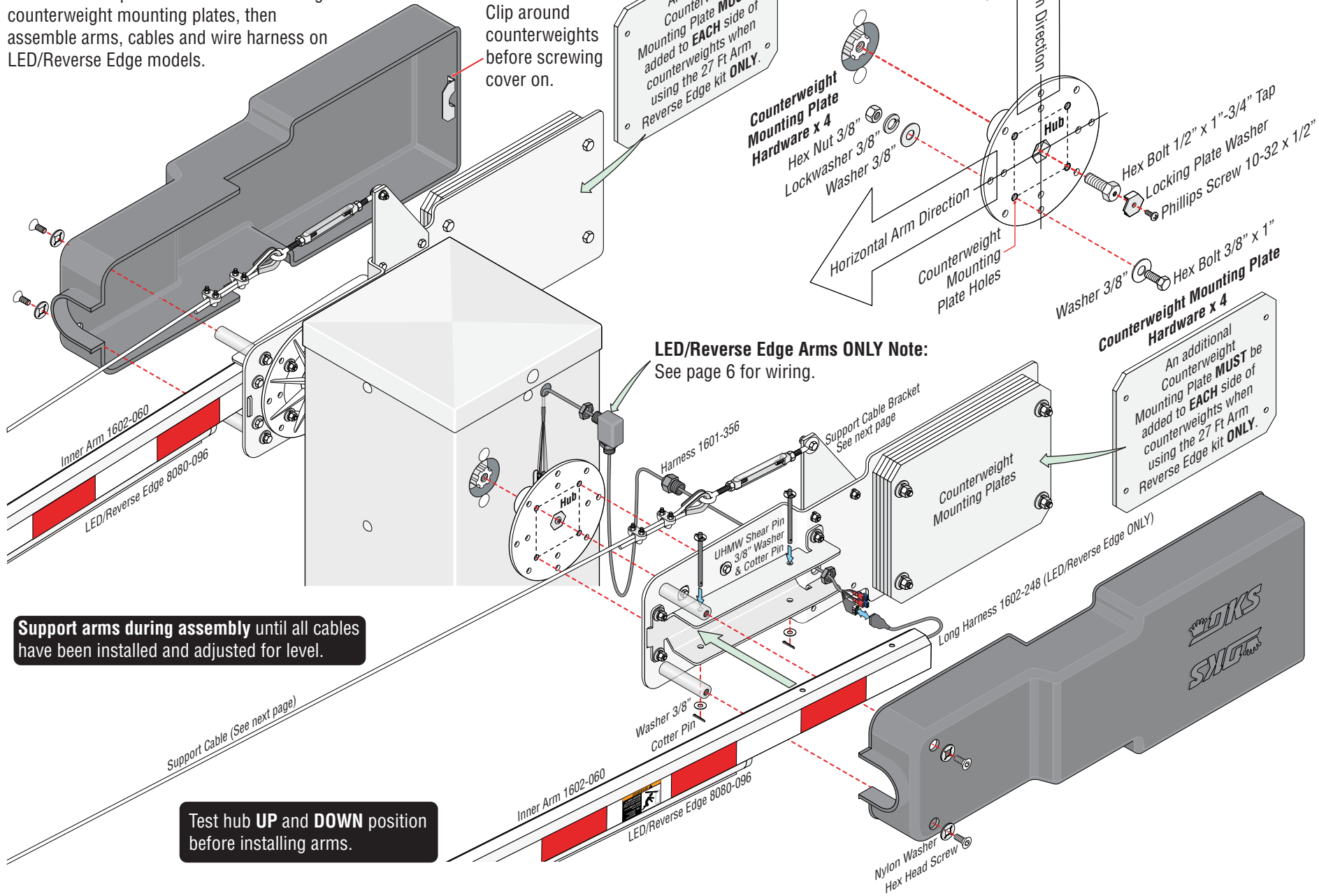

Mounting Hub

An additional Counterweight Mounting Plate **MUST** be added to **EACH** side of counterweights when using the 27 Ft Arm Reverse Edge kit **ONLY**.

Counterweight Mounting Plate Hardware x 4
Hex Nut 3/8"
Lockwasher 3/8"
Washer 3/8"

Hex Bolt 1/2" x 1"-3/4" Tap
Locking Plate Washer
Phillips Screw 10-32 x 1/2"

Washer 3/8" Hex Bolt 3/8" x 1"
Counterweight Mounting Plate Hardware x 4

An additional Counterweight Mounting Plate **MUST** be added to **EACH** side of counterweights when using the 27 Ft Arm Reverse Edge kit **ONLY**.

LED/Reverse Edge Arms ONLY Note:
See page 6 for wiring.

Support arms during assembly until all cables have been installed and adjusted for level.

Test hub UP and DOWN position before installing arms.

Support Cable Bracket Installation

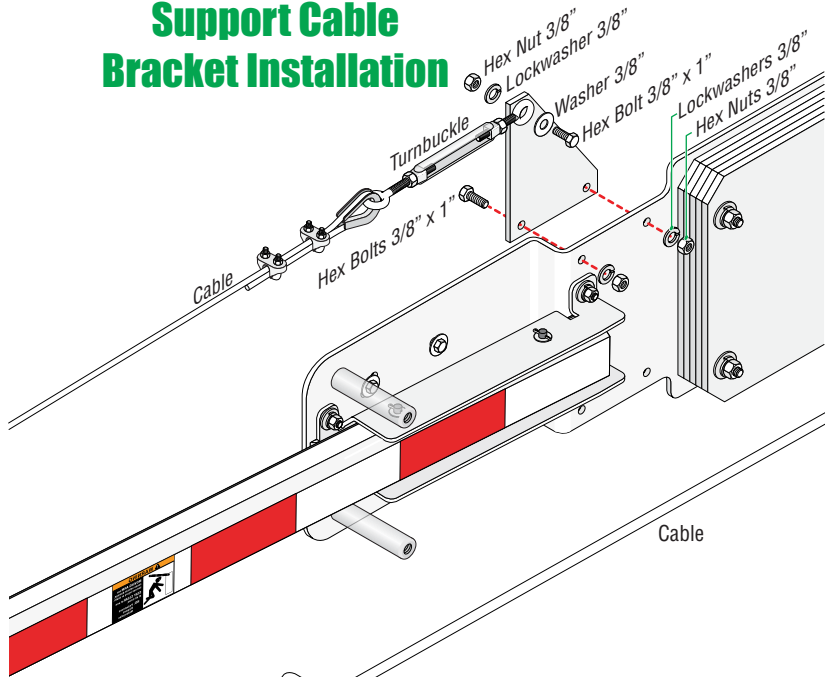

Typical Support Cable Installation

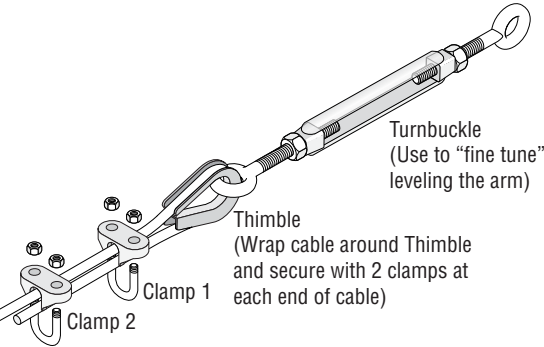

Inner Arms Assembly (Wishbone End)

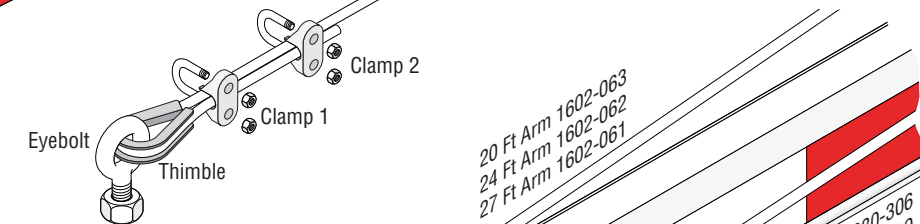
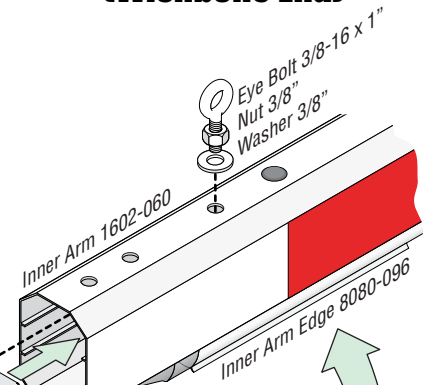

End of Arm Assembly

NOT used for the 20 ft arm.

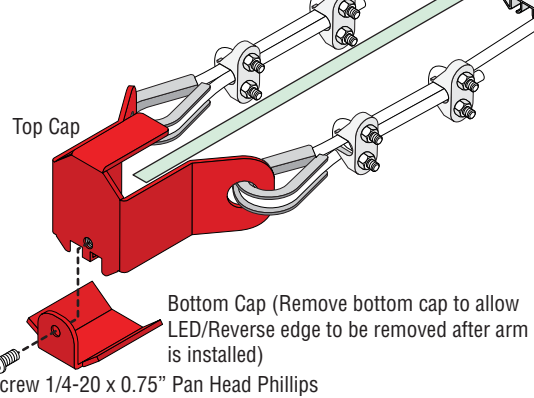

1602-158-B-4-22

Attaching Turnbuckles to Wishbone 24 & 27 ft arms ONLY.

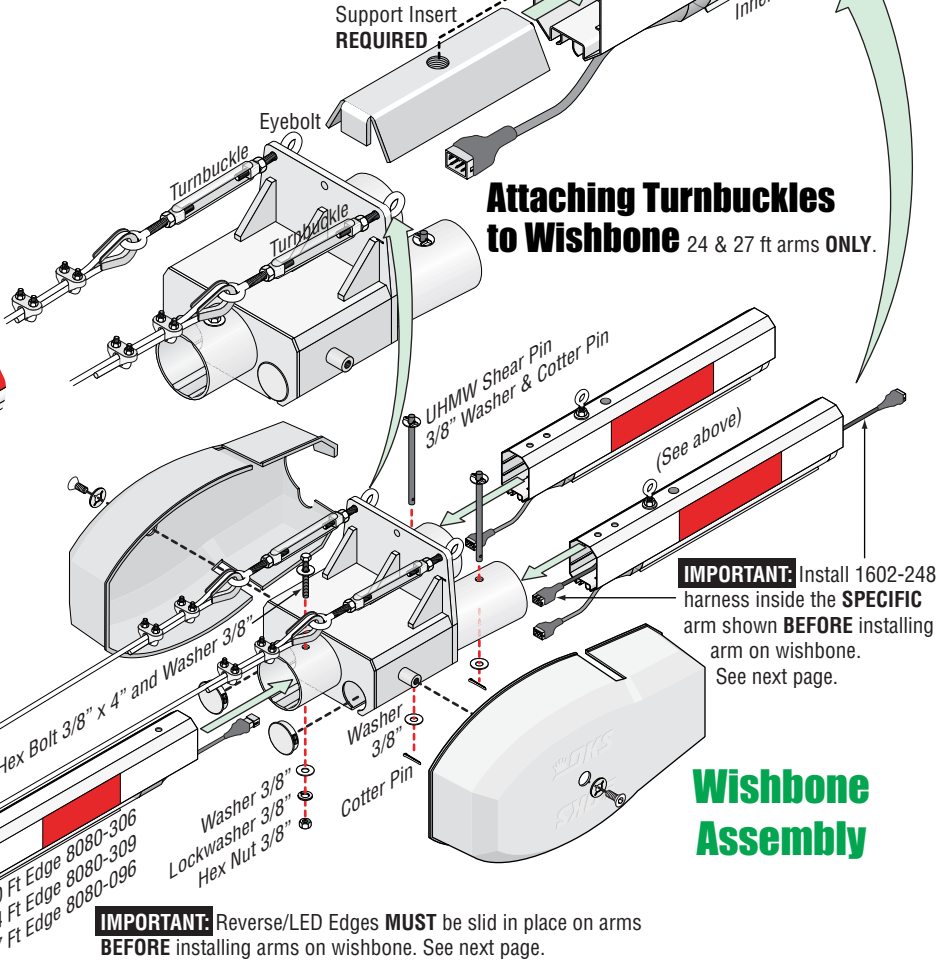

IMPORTANT: Install 1602-248 harness inside the **SPECIFIC** arm shown **BEFORE** installing arm on wishbone. See next page.

Wishbone Assembly

IMPORTANT: Reverse/LED Edges **MUST** be slid in place on arms **BEFORE** installing arms on wishbone. See next page.

LED/Reverse Edge Wiring

Bottom View of Arm

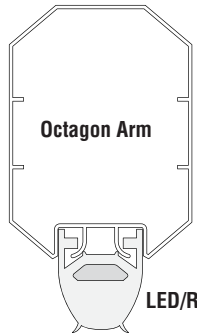
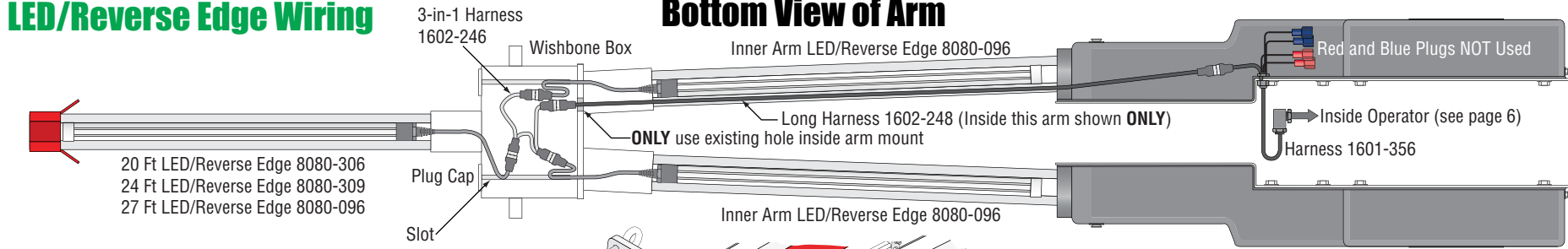

Tip: Liquid soap will help LED/reverse edge slide on easier.

NOTE: All plug connections will fit inside wishbone box. Use the 2 plug holes to make all connections through and slide connected plugs in wishbone box. Use slots to run LED/reverse edge wires through.

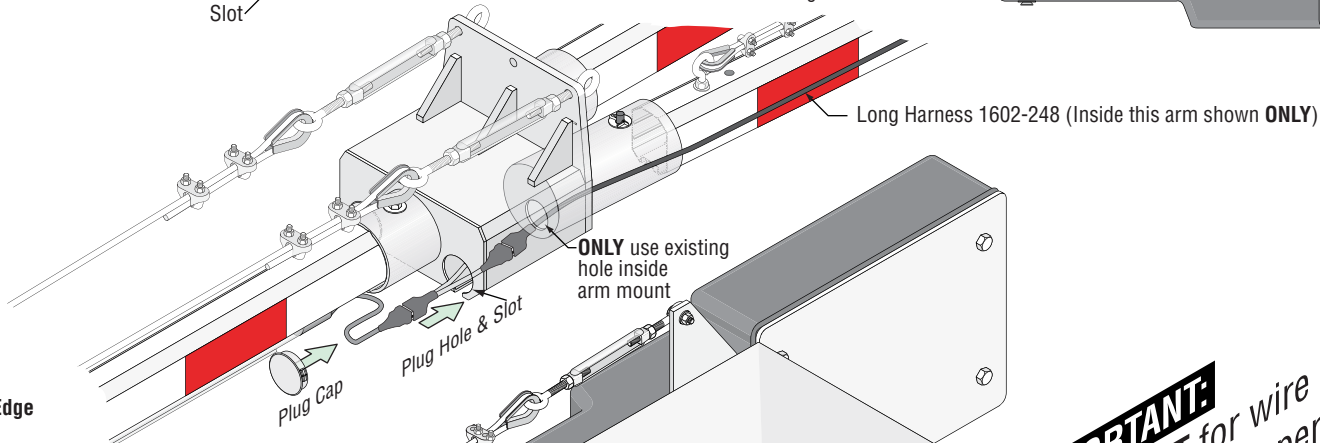

KNOCKOUT

IMPORTANT: **KNOCKOUT** for wire harness is located on **ONE SIDE** of operator **ONLY**.
There needs to be slack in the wire harness 1601-356 for rotating arm.

IMPORTANT: Wire harness MUST remain clear of the rotating arm and the arm cover to avoid wire chaffing.

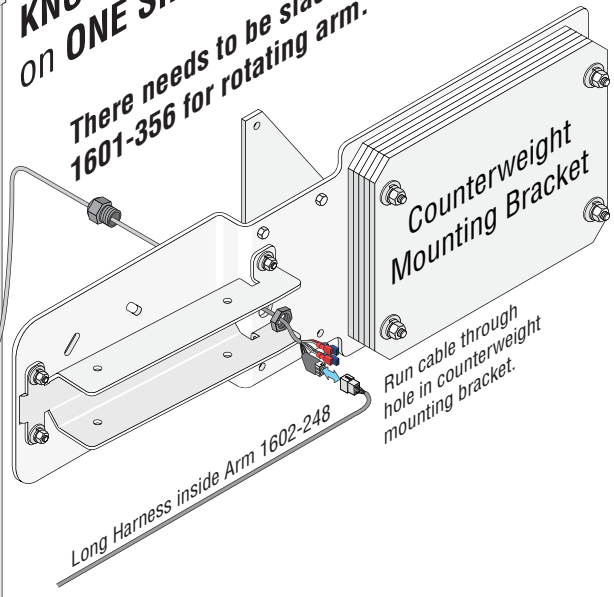

Mount Power Supply

IMPORTANT: Power supply **MUST** be wired **BEFORE** mounting it as shown. See next page.

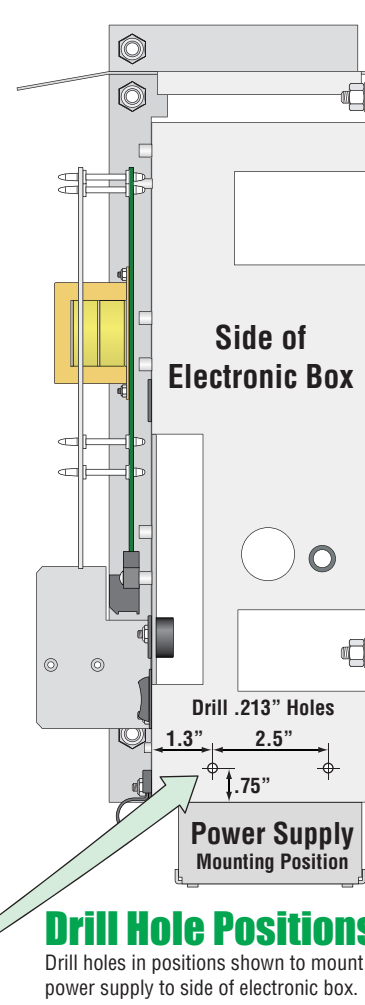
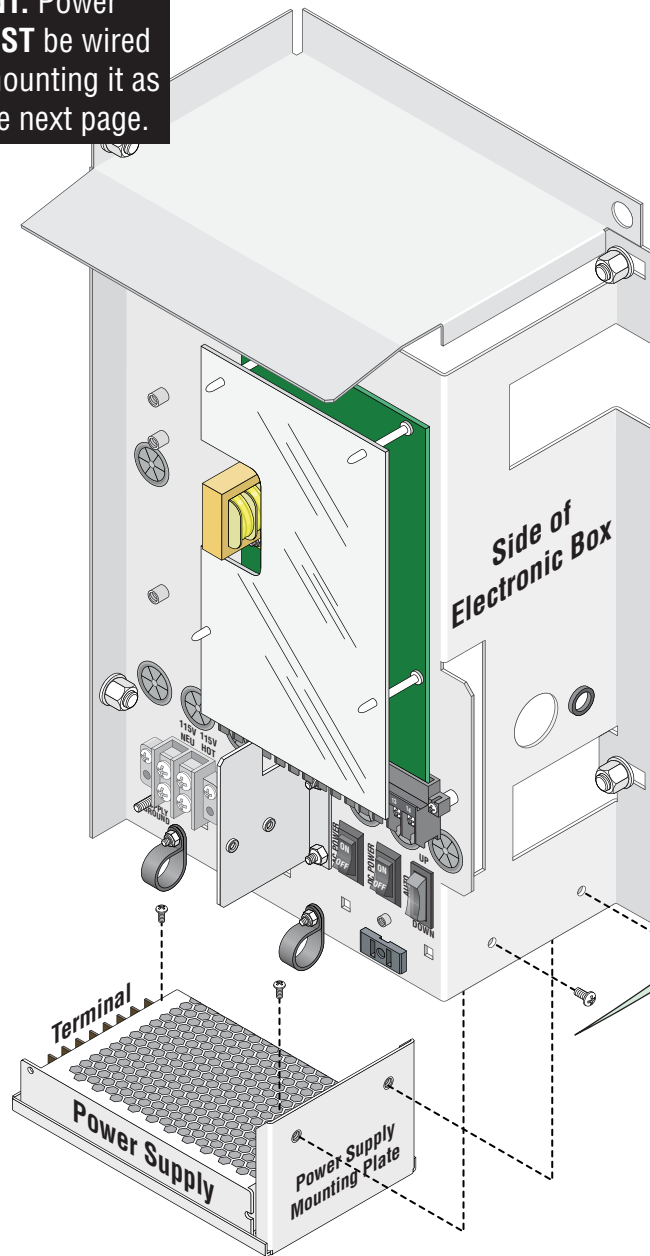

Drill Hole Positions
Drill holes in positions shown to mount power supply to side of electronic box.

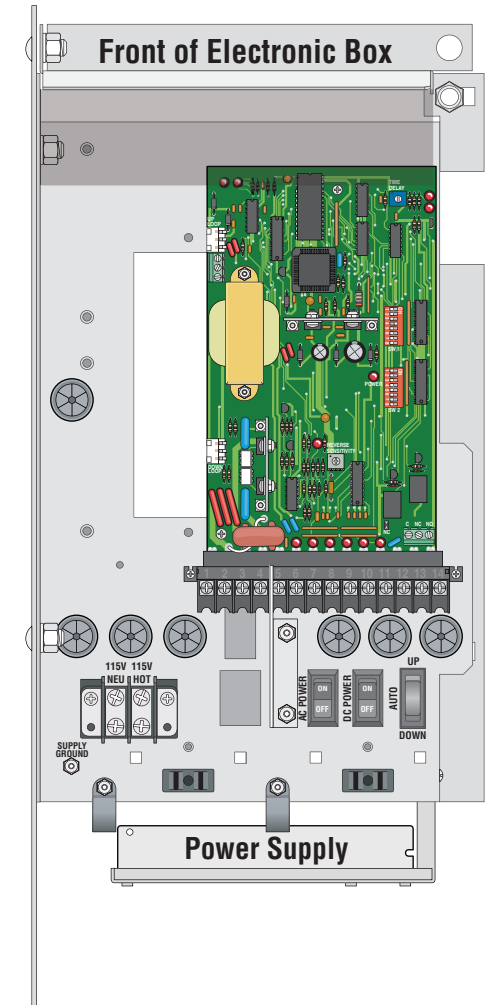

Wiring

MAKE SURE ALL POWER IS TURNED OFF TO OPERATOR!

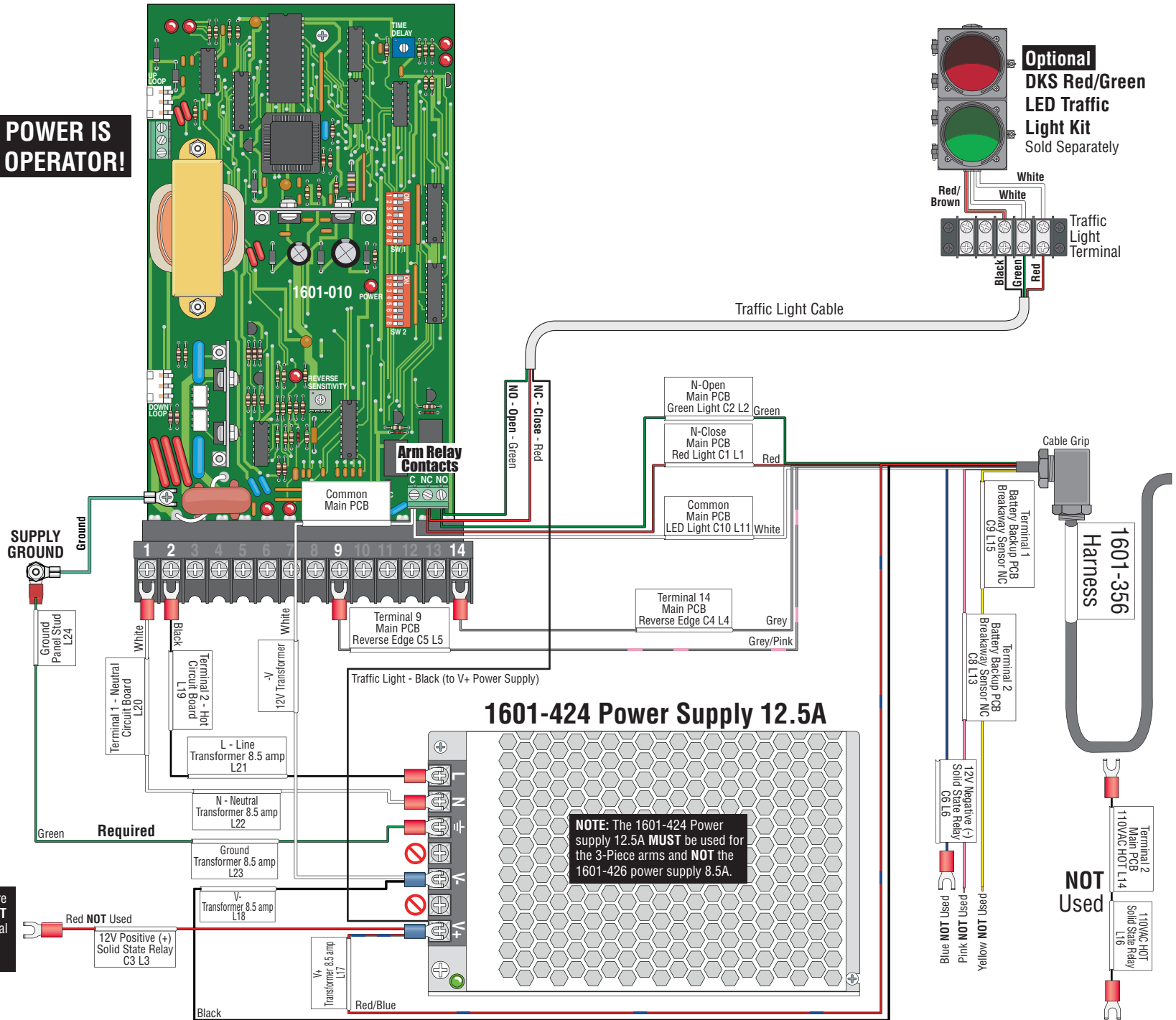

Make sure ANY unused wires are properly terminated and do NOT have exposed bare wires or metal connectors that could cause the operator to malfunction.

NOTE: The 1601-424 Power supply 12.5A MUST be used for the 3-Piece arms and NOT the 1601-426 power supply 8.5A.

3-PIECE OCTAGON ARM ONLY INSTALL

These 3-Piece Arm ONLY are designed **ONLY** for the 1602 model barrier gate operator.

IMPORTANT NOTE: Installation of arms WITH LED/Reverse Edge kit see pages 1-6.

DoorKing Part Numbers:

1602-282
20 ft Arm Only

1602-284
24 ft Arm Only

1602-287
27 ft Arm Only

Overview of Installation

Prior to beginning the installation of the 3-piece arms **ONLY**, see pages 7-9. We suggest that you become familiar with the instructions, illustrations on these pages.

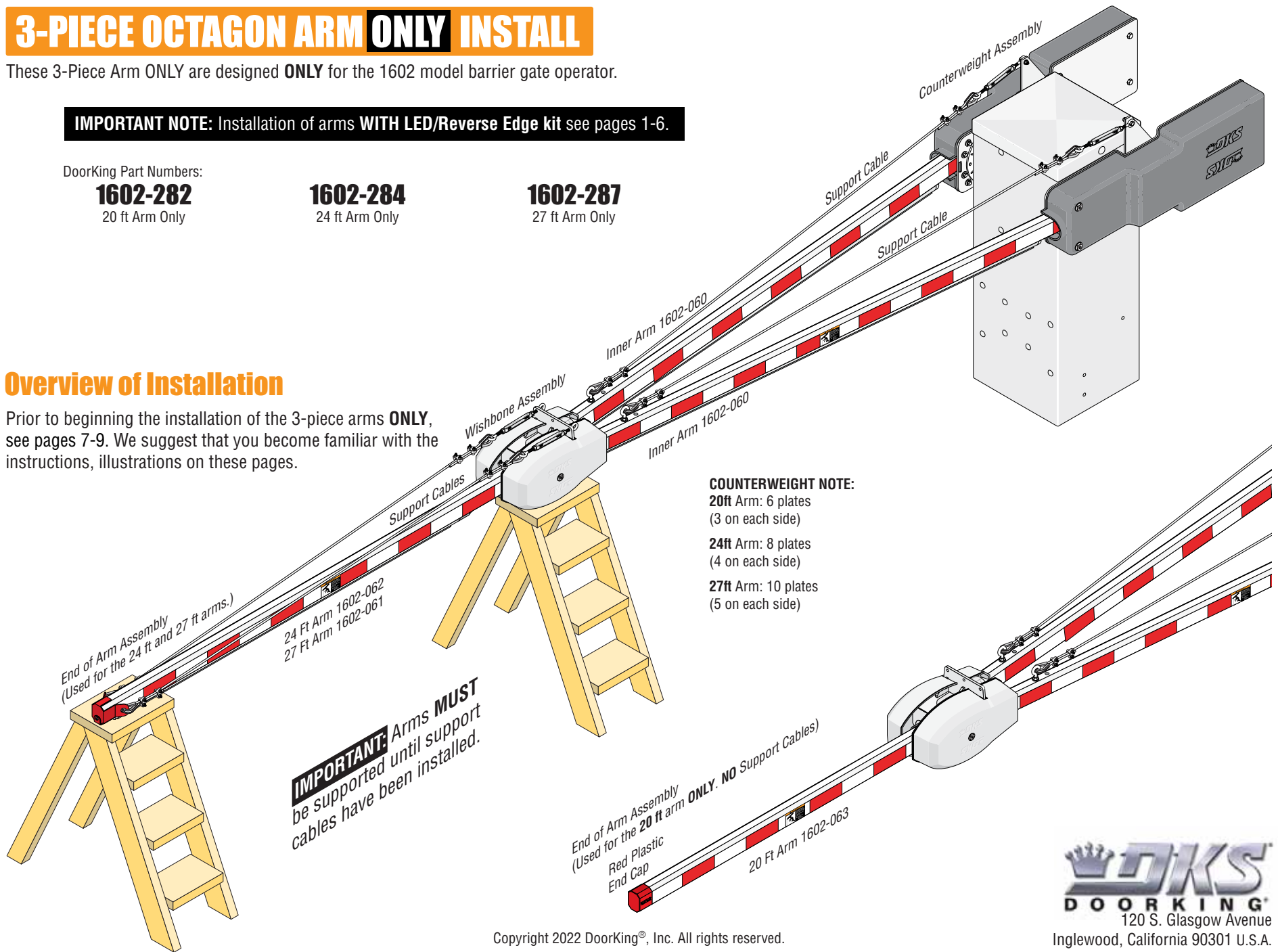

IMPORTANT: Arms **MUST** be supported until support cables have been installed.

COUNTERWEIGHT NOTE:
20ft Arm: 6 plates
(3 on each side)
24ft Arm: 8 plates
(4 on each side)
27ft Arm: 10 plates
(5 on each side)



Copyright 2022 DoorKing®, Inc. All rights reserved.

Counterweight Assembly

Mount hubs on operator **FIRST** Test hubs **UP** and **DOWN** positions **BEFORE** installing counterweight mounting plates, then assemble arms.

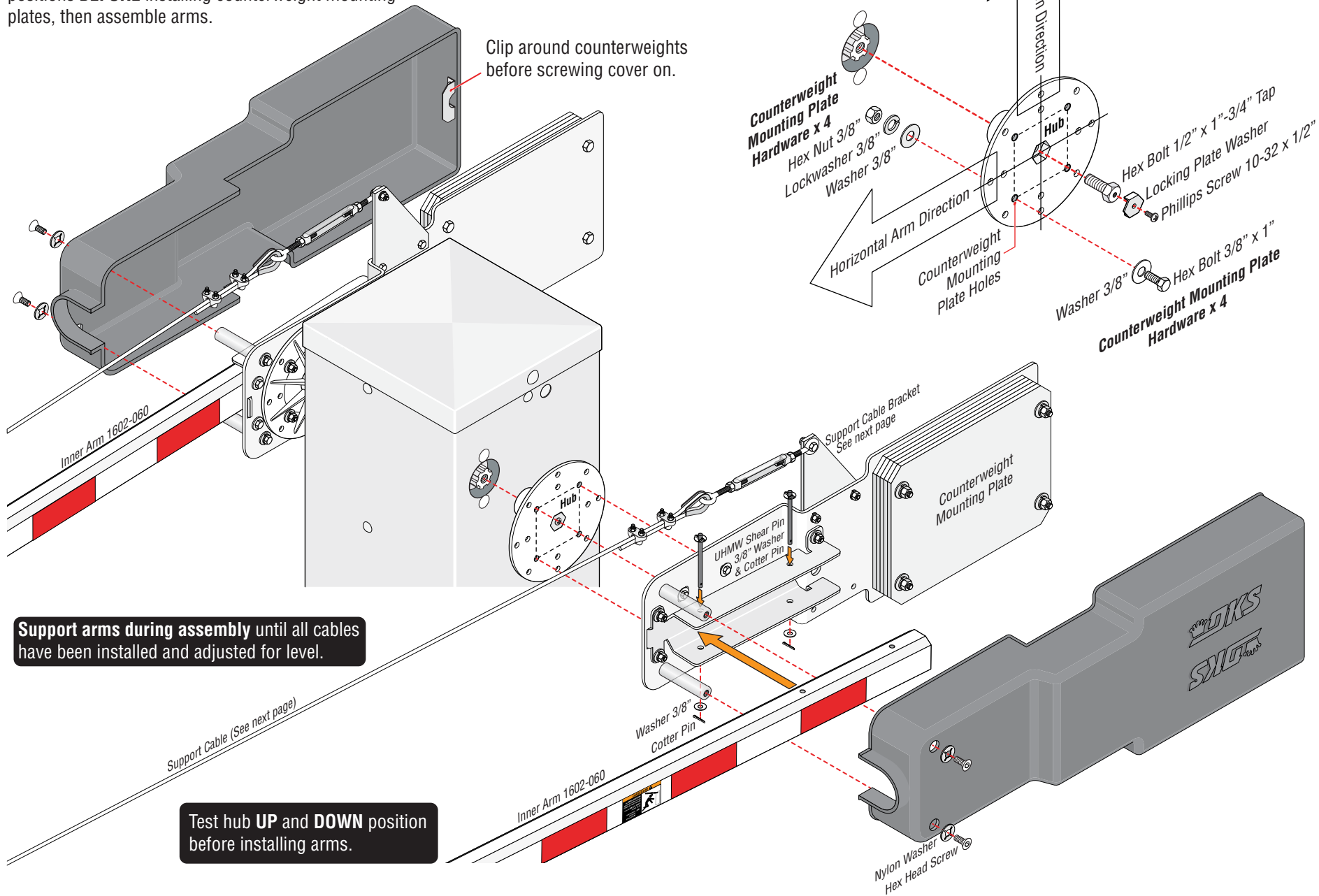

Support arms during assembly until all cables have been installed and adjusted for level.

Test hub **UP** and **DOWN** position before installing arms.

Support Cable Bracket Installation

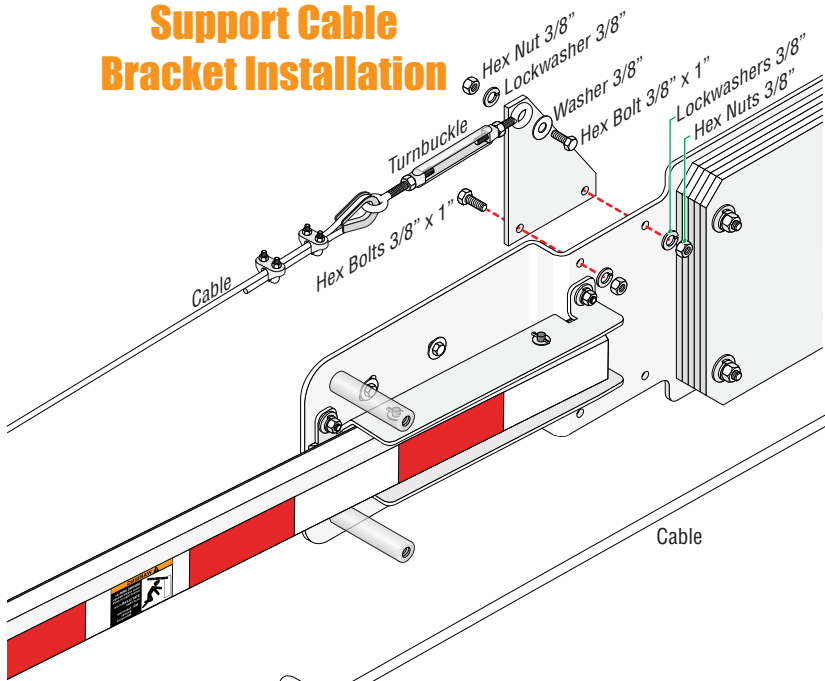

Typical Support Cable Installation

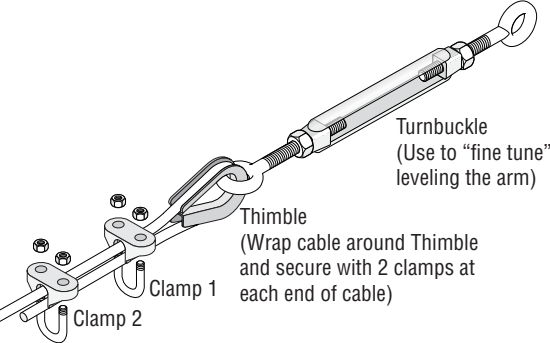

Inner Arms Assembly (Wishbone End)

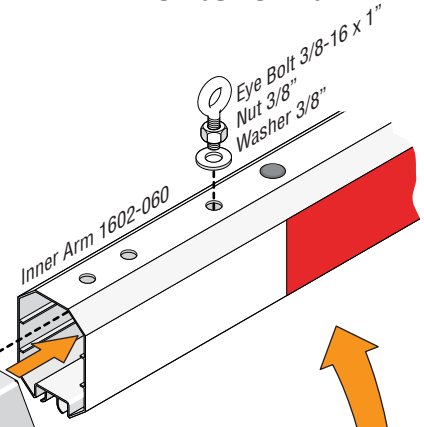

End of Arm Assembly

NOT used for the 20 ft arm.

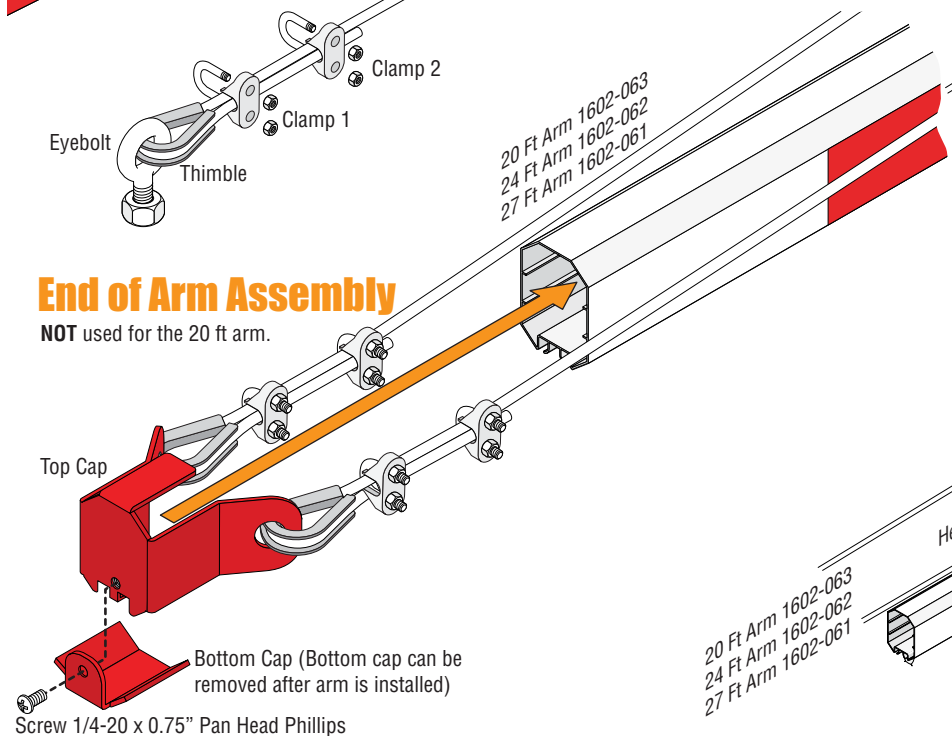

Attaching Turnbuckles to Wishbone 24 & 27 ft arms ONLY.

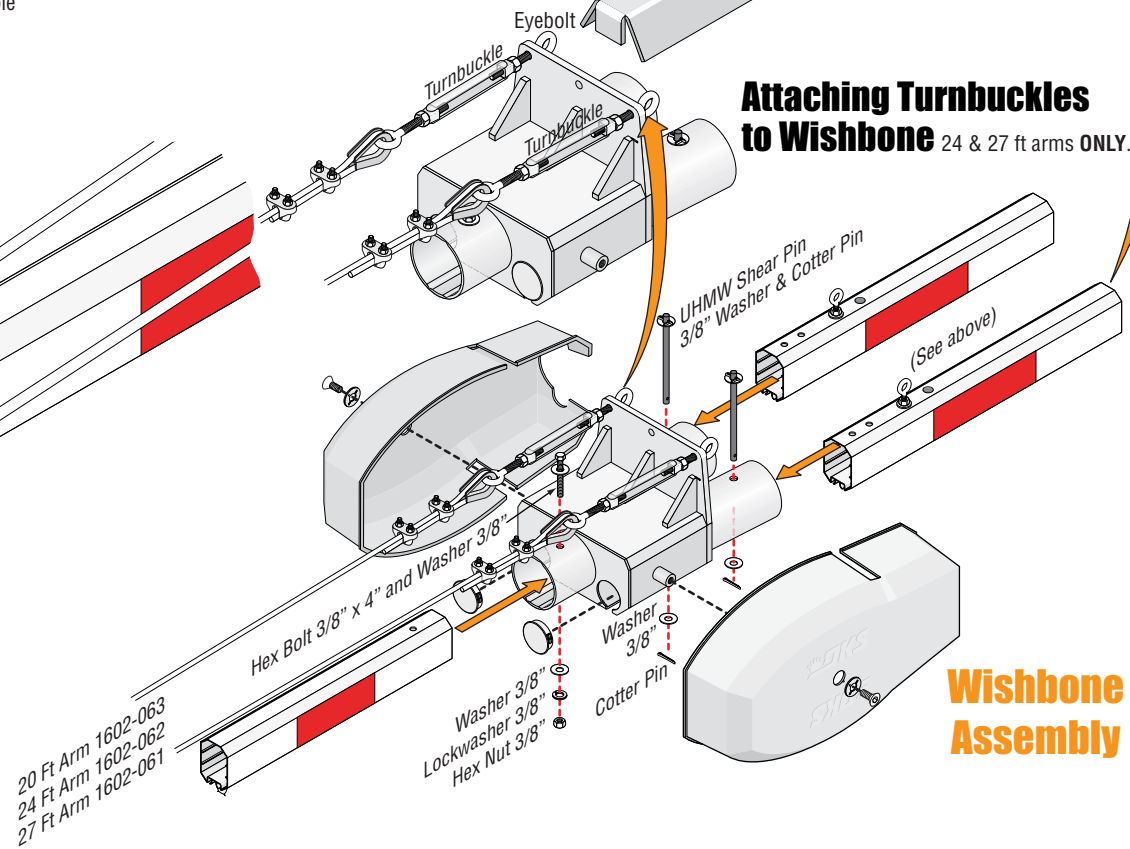

Wishbone Assembly