

TRAFFIC CONTROL

WARNING SIGNS & SIGNAL LIGHTS



REQUIRED SIGNS AND SIGNALS PREVENT INJURY, DAMAGE AND LOST REVENUE

ILLUMINATED WARNING SIGN

- Warning sign includes automatic light sensor
- 12 Watt LED lamp
- 9 Watt LED flood lamp
- Mounts on 3-1/2" (88.9mm) post

TRAFFIC SIGNAL LIGHT

- Red/Green traffic signal can be synchronized with most vehicular gate and barrier gate operators
- Operates on 12 VDC
- Large 8" (203.2mm) red/green lenses
- 7 Watt LED bulbs
- 2 year limited warranty

GATED COMMUNITIES • PARKING • CONDOMINIUM/
RESIDENT HALL • MIXED USE • COMMERCIAL
• SELF STORAGE • MAXIMUM SECURITY



Keyed
on/off switch allows sign to be turned on or off manually



Flood Lamp
for spike illumination



Light Sensor
automatically turns sign on at dusk, off at dawn



Synchronizes
with most vehicular gate and barrier operators



TRAFFIC CONTROL

WARNING SIGNS & SIGNAL LIGHTS

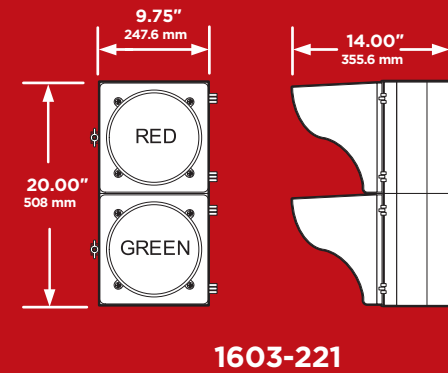
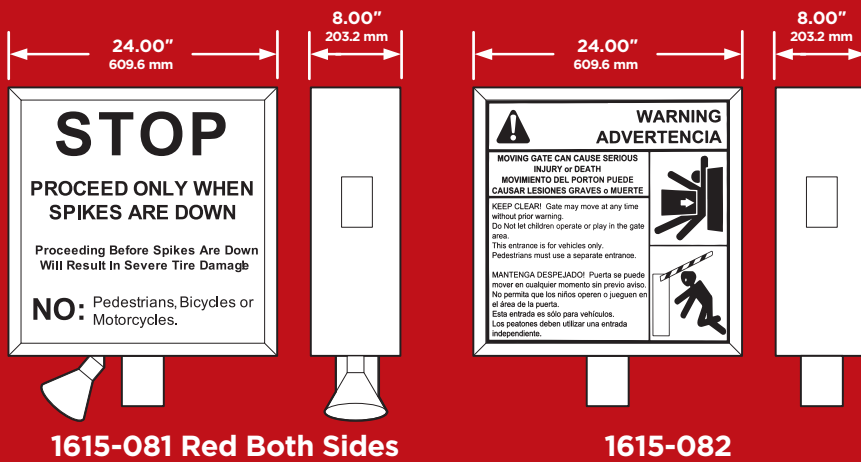
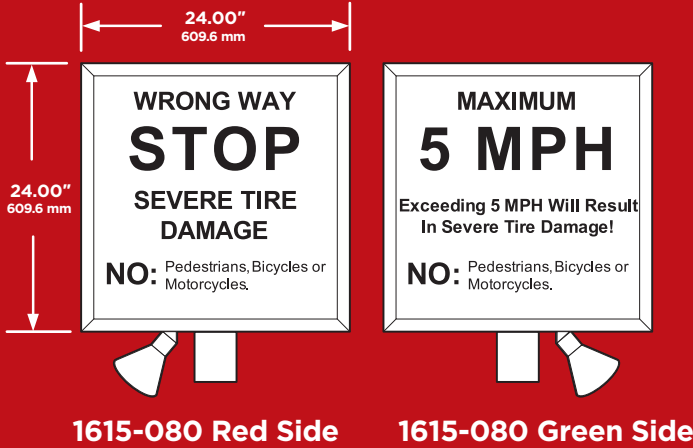

TECHNICAL FEATURES

WARNING SIGN

The DKS Warning Sign must be used with traffic control spikes to warn drivers that a one-way lane condition exists and that proceeding through the lane in the wrong direction will result in severe tire damage. The red side of the sign warns drivers to stop, while the green side warns them not to back up.

A gate warning sign is also available: "Moving gate can cause serious injury or death". The gate warning sign does not include the flood lamp.

With the built-in light sensor, the signs automatically illuminate at dusk and turn off at dawn.

Mounting

3-1/2" (88.9mm) post (not included)

Power

Operates on 115 VAC
12 Watt T8 LED tube lamp, 700 lumens
9 Watt LED flood lamp, 655 lumens

Features

8" (20.3mm) lenses (red/green)
Includes lens shield
U.L. Listed

Shipping Weight

35 lbs (15.8kg)

TRAFFIC SIGNAL

The DKS Traffic Signal is an ideal accessory for any automated vehicular gate system. The traffic signal is especially useful for use with barrier gate operators and provides drivers with a visible indication of when it is safe to proceed through the traffic lane. The signal is synchronized with the movement of the gate so that the red signal is on at all times and changes to green only when the gate is open or the barrier arm is up.

Mounting

2" pipe (5.08mm)

Power

Operates on 12 VDC

Features

8" (20.3mm) lenses (red/green)
Includes lens shield
U.L. Listed

Shipping Weight

25 lbs (11.3kg)

DoorKing® Inc.

Access Control Solutions since 1948



120 S. Glasgow Avenue,
Inglewood, California 90301 U.S.A.
Tel: 310-645-0023 FAX: 310-641-1586
www.doorking.com

© 2022 All Rights Reserved.
Product specifications may
change without notice. Rev. 2/22



MEMBER:



DISTRIBUTED BY:

