

# ILLUSTRATED PARTS BREAKDOWN - IPB

## Bill of Materials - BOM

### 1812 Classic Surface Mount 1812-081 Stainless Steel, 1812-085 Gold Plated

Item	Part Number	Quantity	UM	Description
10	1502-005	1	EA	Cover Plastic
15	1812-023	1	EA	Decal FCC
20	1400-009	1	EA	Decal Identification
25	1804-039	2	EA	Retaining Strip Keypad
30	2599-008	1	EA	Label Patent
35	2356-006	1	EA	PCB LED Single LED
40	4001-035	1	EA	Lock N16058BDxSFx2K Key 16120
40	4001-036	1	EA 1812-085 only	Lock Gold N16058BDxSFx2K
43	1702-501	1	EA	Cam 7/8"
50	2902-003	13	EA	Nut Nylon Lock 6-32
55	1812-102	1	EA	Box Phone Surface for 1871
57	1998-010	1	EA	PCB Microphone Short, SMT
60	1812-052	1	EA	Faceplate Phone
60	1812-056	1	EA 1812-085 only	Faceplate Phone Gold
65	1812-029	1	EA	Subplate Phone
70	1871-010	1	EA	PCB Residential No Phone Line
75	1875-010	1	EA	PCB Pass Switch
77	2616-443	4	EA	Screw Phillips
80	2905-003	4	EA	Screw Round Head 6-32 x 1/2"
85	1860-126	4	EA	Washer Nylon Shoulder
86	1860-032	4	EA	Washer Nylon Retaining #6
90	2616-003	4	EA	Screw Phillips Head 6-32x3/4SS
97	2900-928	1	EA	Standoff Stel Male/Female 1/4"
100	3140-045	1	EA	Label 1812 New Wiring
105	1804-059	1	EA	Transformer 24 VAC, 20 VA
115	1804-028	3	EA	Mount Wire Clip
121	1812-131	1	EA	Bracket Microphone
125	1804-058	1	EA	Speaker Assembly Mylar 8 ohm 3.5"square
130	1895-017	1	EA	Keypad 10 Pin Numbers Header
133	1804-038	1	EA	Wire Ribbon Cable Assy 10 Cond
135	1812-017	1	EA	Push Button Assembly
142	1812-065	1	EA	Manual - Installation
145	1804-031	5	EA	Tie Wrap 4"
151	2600-734	1	EA	Nameplate Plastic DKS Small
152	2802-040	2	EA	Washer Push on Clamp
153	1897-050	2	EA	Gasket Support Thick 1/16"
160	2600-884	1	EA	Label E.T.L. Separable
160	1804-157	1	EA 1812-085 only	Keypad Assembly Gold Alph/Num
165	1812-060	1	EA	Remote 1812 Program CD Assy
180	9402-053	10	IN	Tubing Flex/slit 1/4OD
185	1804-196	1	EA	Speaker Gasket 1/16" thick
190	1897-053	1	EA	Gasket, Microphone
195	2600-794	1	EA	Hole Plug Blk Nylon .187" dia.
200	1800-018	1.66	FT	Weather Strip .125"x .187"
201		1	EA	Wire Harness 1812 Front Panel
	1812-163	1	EA	Manual Classic QuickStart 1812

# 1812 Classic Surface Mount

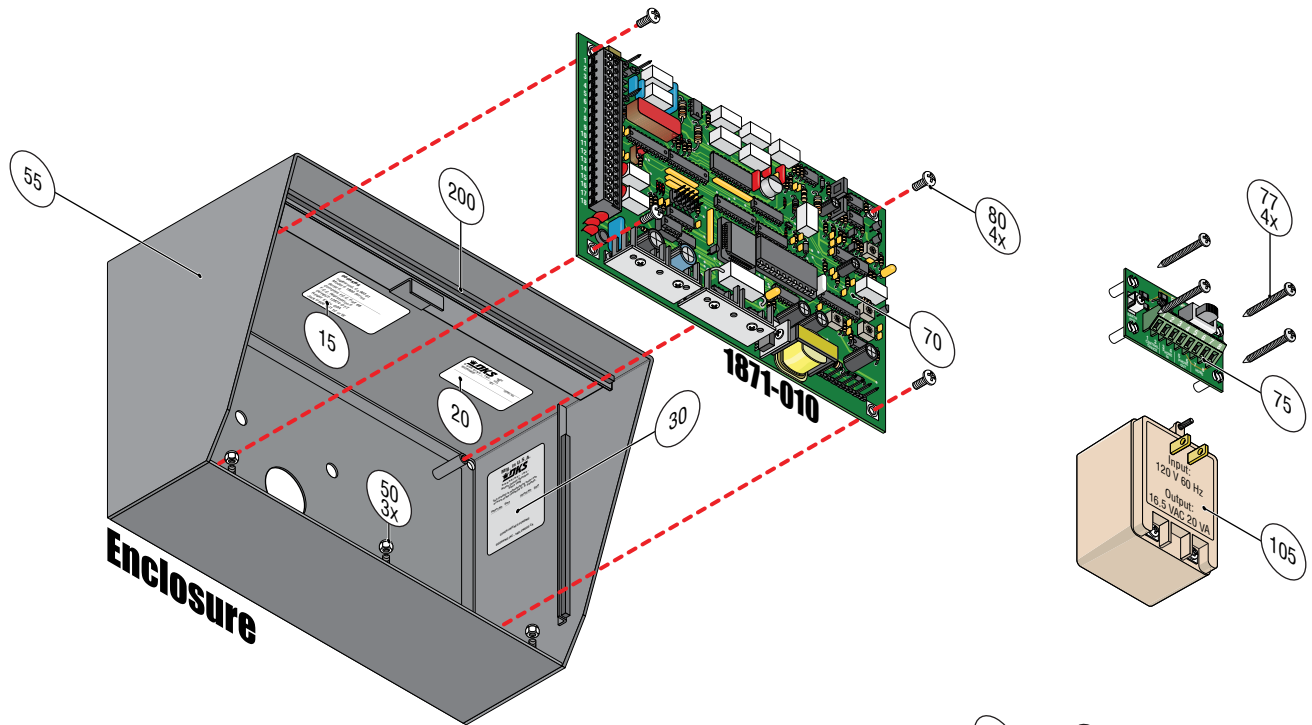

- 1812-081 and 1812-085
- 1812-085 Gold Plated Only

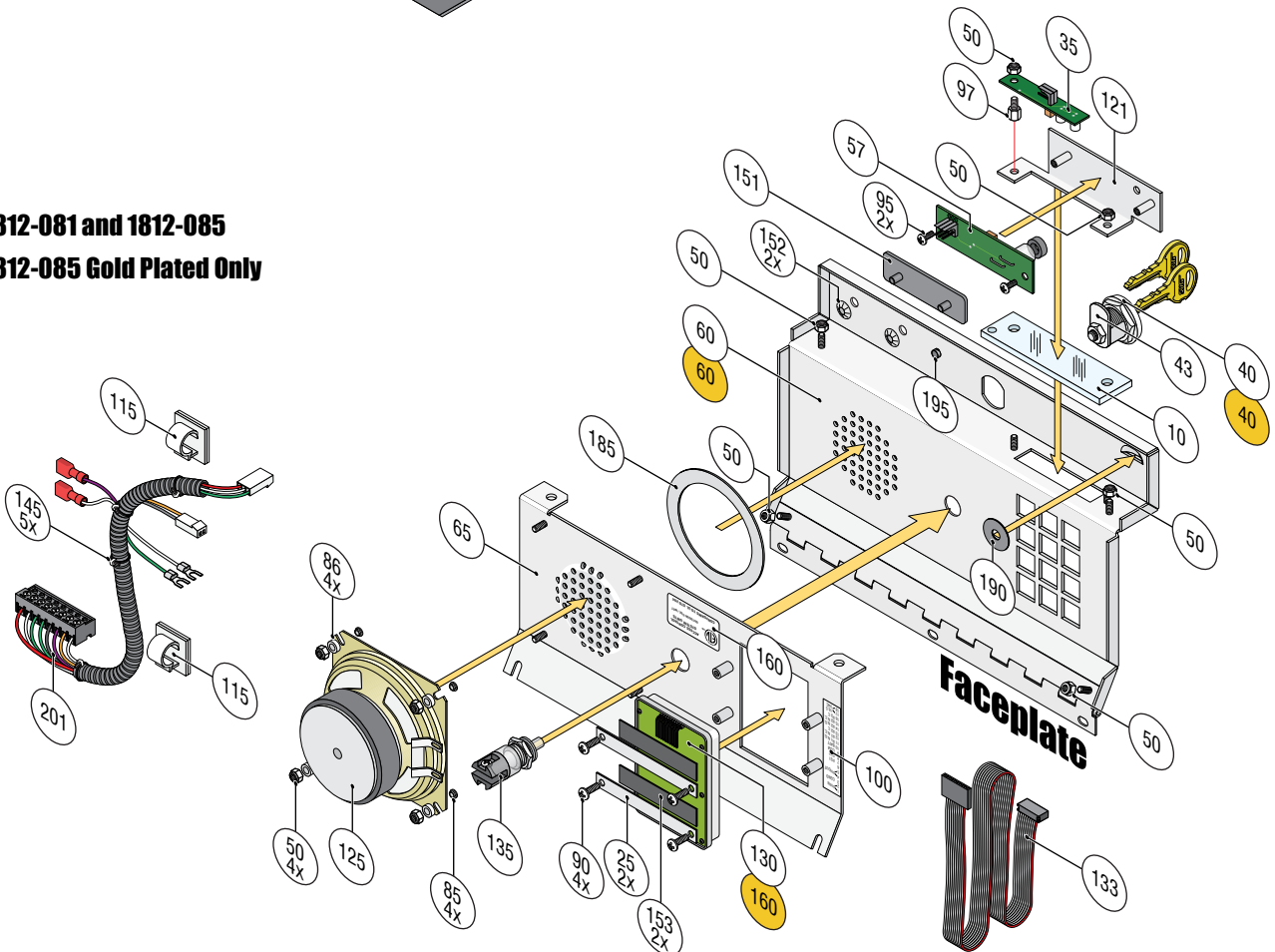

# ILLUSTRATED PARTS BREAKDOWN - IPB

## Bill of Materials - BOM

### 1812 Classic Flush Mount 1812-087 Stainless Steel, 1812-086 Gold Plated

Item	Part Number	Quantity	UM	Description
10	1502-005	1	EA	Cover Plastic
15	1812-023	1	EA	Decal FCC
20	1400-009	1	EA	Decal Identification
25	1804-039	2	EA	Retaining Strip Keypad
30	2599-008	1	EA	Label Patent
35	2356-006	1	EA	PCB LED Single LED
37	2900-928	1	EA	Standoff Stel Male/Female 1/4"
40	4001-035	1	EA	Lock N16058BDxSFx2K Key 16120
40	4001-036	1	EA	1812-086 only Lock Gold N16058BDxSFx2K
43	1702-501	1	EA	Cam 7/8"
50	2902-003	13	EA	Nut Nylon Lock 6-32
55	1812-107	1	EA	Box Trim Stainless Steel
55	1812-109	1	EA	1812-086 only Box Trim Gold
57	1812-155	1	EA	Box Rough In
58	1998-010	1	EA	PCB Microphone Short, SMT
60	1812-052	1	EA	Faceplate Phone
60	1812-056	1	EA	1812-086 only Faceplate Phone Gold
65	1812-029	1	EA	Subplate Phone
70	1871-010	1	EA	PCB Residential No Phone Line
75	1875-010	1	EA	PCB Pass Switch
77	2616-443	4	EA	Screw Phillips
78	2616-052	4	EA	Screw Phillips Head 10-32 x1/2
79	2616-001	4	EA	Screw Phillips Head 6-32 x 3/8
80	2905-003	4	EA	Screw Round Head 6-32 x 1/2"
85	1860-126	4	EA	Washer Nylon Shoulder
86	1860-032	4	EA	Washer Nylon Retaining #6
100	3140-045	1	EA	Label 1812 New Wiring
105	1804-059	1	EA	Transformer 24 VAC, 20 VA
115	1804-028	3	EA	Mount Wire Clip
121	1812-131	1	EA	Bracket Microphone
125	1804-058	1	EA	Speaker Assembly Mylar 8 ohm 3.5"square
130	1895-017	1	EA	Keypad 10 Pin Numbers Header
130	1804-157	1	EA	1812-086 only Keypad Assembly Gold Alph/Num
133	1804-038	1	EA	Wire Ribbon Cable Assy 10 Cond
135	1812-017	1	EA	Push Button Assembly
142	1812-065	1	EA	Manual - Installation
145	1804-031	5	EA	Tie Wrap 4"
151	2600-734	1	EA	Nameplate Plastic DKS Small
152	2802-040	2	EA	Washer Push on Clamp
153	1897-050	2	EA	Gasket Support Thick 1/16"
160	2600-884	1	EA	Label E.T.L. Separable
165	1812-060	1	EA	Remote 1812 Program CD Assy
180	1804-196	1	EA	Speaker Gasket 1/16" thick
185	1897-053	1	EA	Gasket, Microphone
190	2600-794	1	EA	Hole Plug Blk Nylon .187" dia.
200	1800-018	1.66	FT	Weather Strip .125"x .187"185
201		1	EA	Wire Harness 1812 Front Panel
	1812-163	1	EA	Manual Classic QuickStart 1812





# 1812 Classic Wall Mount

