

GV-AS4111/8111 Kit

User's Manual

Before attempting to connect or operate this product, please read these instructions carefully and save this manual for future use.



© 2016 GeoVision, Inc. All rights reserved.

Under the copyright laws, this manual may not be copied, in whole or in part, without the written consent of GeoVision.

Every effort has been made to ensure that the information in this manual is accurate. GeoVision, Inc. makes no expressed or implied warranty of any kind and assumes no responsibility for errors or omissions. No liability is assumed for incidental or consequential damages arising from the use of the information or products contained herein. Features and specifications are subject to change without notice.

GeoVision, Inc.
9F, No. 246, Sec. 1, Neihu Rd.,
Neihu District, Taipei, Taiwan
Tel: +886-2-8797-8377
Fax: +886-2-8797-8335
<http://www.geovision.com.tw>

Trademarks used in this manual: *GeoVision*, the *GeoVision* logo and GV series products are trademarks of GeoVision, Inc.

September 2016

Contents

Compatible Devices	1
Installation Considerations.....	2
Definition	3
1 Introduction.....	4
1.1 Main Features	4
1.2 Packing List	5
2 Installation.....	7
2.1 Connecting Card Readers.....	7
2.1.1 Wiegand Readers.....	7
2.1.2 RS-485 Readers.....	8
2.2 Connecting Input Devices	10
2.3 Connecting Output Devices.....	11
2.4 Connecting Backup Battery.....	12
2.5 Connecting the Power	12
2.6 Connecting the PC.....	13
3 Other Settings.....	15
3.1 Web Setting Switch	15
3.2 Resetting the GV-AS4111 / 8111	15
3.3 Restoring Factory Defaults.....	16
4 GV-AS4111 / 8111 Kit.....	17
4.1 Packing List	17
4.2 GV-AS4111 / 8111 Kit Overview	18
4.3 GV-AS4111 / 8111 Kit Standard Application	19
4.4 Connecting the GV-AS4111 / 8111 Kit	20
4.5 GV-AS4111 / 8111 Kit Specifications	22
5 The Web Interface.....	23
6 GV-AS4111 / 8111 Specifications	24

Compatible Devices

Compatible devices can expand the capabilities and versatilities of your GV-AS Controllers. Consult your sales representative for more information.

GV-RK1352	GV-RK1352 is a card reader with keypad that uses a 13.56 MHz frequency. The reader has both Wiegand and RS-485 outputs that can be connected to GV-AS series control panel.
GV-R1352	GV-R1352 is a card reader that uses a 13.56 MHz frequency. The reader has both Wiegand and RS-485 outputs that can be connected to GV-AS series control panel.
GV-DFR1352	The GV-DFR1352 is a card reader designed to be installed on the door frame for recognizing identification cards. Featured with the Wiegand and RS-485 outputs, the unit can be connected to GV-AS series control panel.
GV-AS4111 / 8111 Kit	GV-AS4111 / 8111 Kit is a cabinet containing a GV-AS4111 or GV-AS 8111, a power adapter board, a power supply and a casing for backup battery. The power supply provides power to GV-AS4111 / 8111 and up to 8 output devices (12V, 0.5A per device).

Installation Considerations

1. There are distance limitations for Wiegand and RS-485 communications using GV-AS4111 / 8111. Please note:

- **Wiegand interface:** 100 meters (328.1 feet)
Recommended Wiegand cable: Wiegand cable (a twisted pair of 24 AWG wires)
- **RS-485 interface:** 600 meters (1968.50 feet)
Recommended RS-485 cable: standard 485 cable (a twisted pair of 24 AWG wires)

Note:

1. For RS-485 connection between GV-AS Controllers and readers, use additional power for the readers when the distance ranges from 30.48 meters ~ 600 meters (100 ft ~ 1968.50 ft). There is no need to use additional power when the distance is within 30.48 meters (100 ft).

2. Recommended power supply:

Manufacturer	Model	Output rating
Powertron	PA1015-2I	12V, 1.25A, 15W Max

3. The location and wiring methods shall be in accordance with the National Electrical Code, ANSI/NFPA 70.

2. GV-ASManager software is used to manage GV-AS Controllers. There is a limit for the number of controllers connected to GV-ASManager based on communication modes.

- **Through network connection,** up to 1000 GV-AS Controllers can connect to GV-ASManager.

Note:

1. For GV-AS4111 / 8111, it is highly recommended to replace the button cell battery included on the circuit board annually.
 2. All control units shall be mounted in a protected area.
-

Definition

Tampering Alarm	<p>To enable tampering alarm, install the sensor separately. The triggering conditions depend on the type of sensor installed.</p> <p>The GV-AS Controller also provides output relays for activating and deactivating electric lock, siren and emergency door release when tampering is detected by the sensors.</p>
------------------------	---

1 Introduction

1.1 Main Features

GV-AS4111

- One-way control: 4 doors
- Two-way control: 4 doors by Wiegand / RS-485 / Network
- Support 8 Wiegand card readers of 26 to 64 bits
- Support 8 GV-Readers through RS-485 connection / Network
- Built-in 16 digital inputs and 24 relay outputs
- Suitable for doors, parking gates and access to elevator call buttons
- Support for tampering alarm

GV-AS8111

- One-way control: 8 doors
- Two-way control: 4 doors by Wiegand only; 8 doors by RS-485 or network; 8 doors with max 4 doors by Wiegand and other doors by RS-485 / network
- Support 8 Wiegand card readers of 26 to 64 bits
- Support 16 GV-Readers through RS-485 connection / Network
- Built-in 16 digital inputs and 24 relay outputs
- Suitable for doors, parking gates and access to elevator call buttons
- Support for tampering alarm

1.2 Packing List

GV-AS4111

- Power Adapter (12V DC, 3.5A)
- Power Cord
- Battery Cable
- Screw x 8
- Hex Nut x 8
- Hex Pillar x 8
- Micro SD Card 2 GB
- Software CD
- Warranty Card

GV-AS8111

- Power Adapter (12V DC, 5A)
- Power Cord
- Battery Cable
- Screw x 8
- Hex Nut x 8
- Hex Pillar x 8
- Micro SD Card 2 GB
- Software CD
- Warranty Card

1.3 GV-AS4111 / 8111 Board Layout

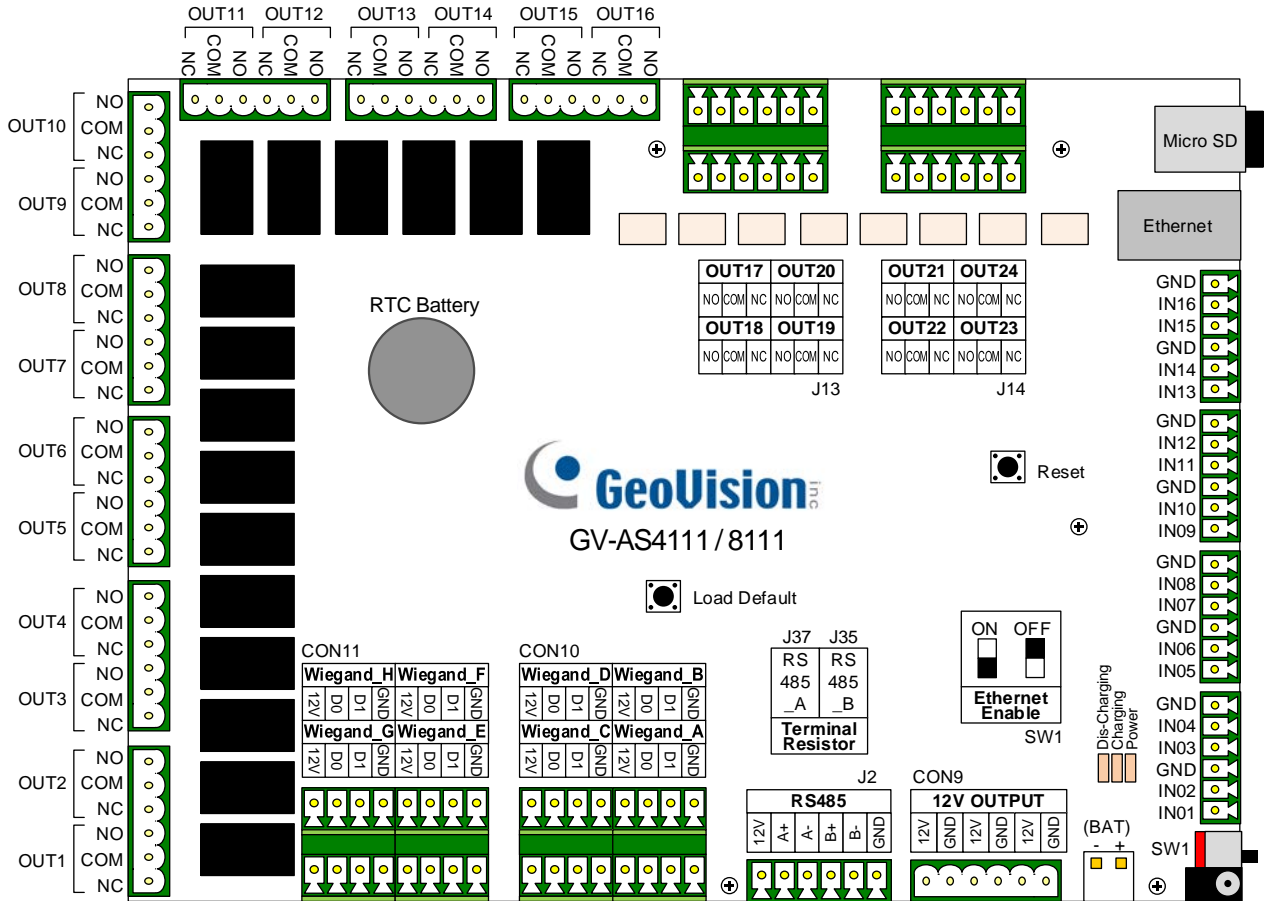

Figure 1

2 Installation

Note: A knockout shall be provided with a surrounding surface that can seat a conduit bushing as intended. The knockout shall be located so that installation of a bushing at any knockout likely to be used during installation will not result in spacings between uninsulated live parts and the bushing of less than those indicated in spacings.

2.1 Connecting Card Readers

GV-AS4111 / 8111 supports two types of card reader interfaces:

- **Wiegand:** Compatible with any Wiegand card readers of 26 to 64 bits.
- **RS-485:** Only compatible with all **GV-Readers**.

2.1.1 Wiegand Readers

GV-AS4111 / 8111 provides 8 Wiegand inputs (Wiegand A to Wiegand H). Connect up to 8 Wiegand readers ranging from 26 to 64 bits to the Wiegand interfaces. Please consult the documentation of your Wiegand reader for wiring.

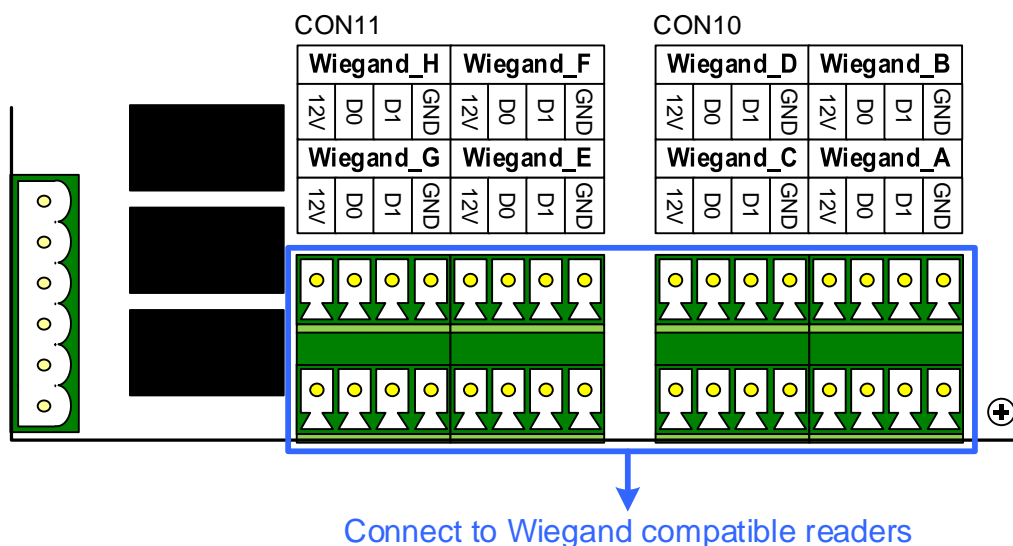

Figure 2

Note: Although 8 Wiegand inputs are available, GV-AS4111 only supports control of up to 4 doors.

2.1.2 RS-485 Readers

For long-distance connection and non-Wiegand card readers, you can connect RS-485 connection with any GV-Readers. Using a single RS-485 cable, up to **8 readers** can be connected together with to the RS-485 A+ / A- interface. For GV-AS8111, another 8 readers can be connected to the RS-485 B+ / B- interface, for a total of **16 RS-485 readers**.

When multiple readers are connected together, an extra power supply to each unit is required. Use **12V** power output and **GND** on the power terminal or the Wiegand connectors to power on each unit.

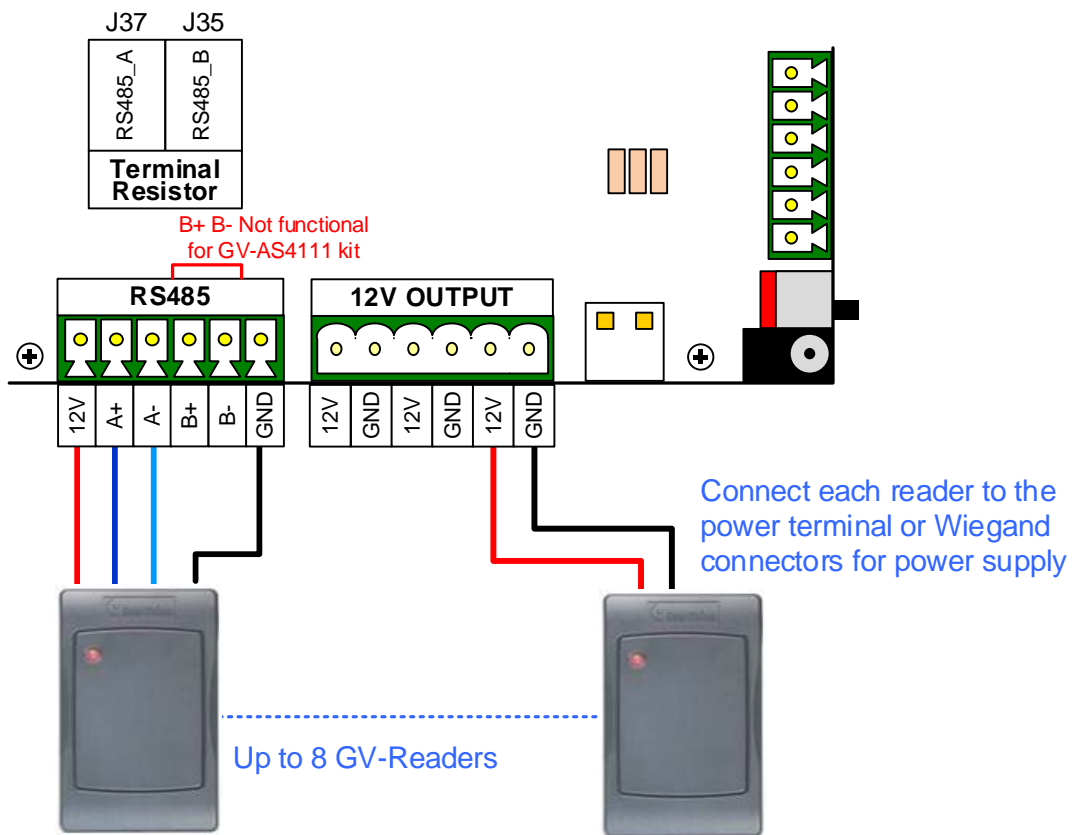

Figure 3

Note:

1. Each set of 12V power output and GND can provide power for up to 2 readers. The 3 sets on the power terminal can support up to 6 readers. If you wish to connect more readers and the Wiegand interfaces are already occupied, you can connect the readers to external power source.
 2. By default, a jumper cap is installed on the RS485_A Terminal Resister (J37) to ensure stability when the RS-485 connection between GV-AS4111 / 8111 and the reader is 600 meters.
 3. Although up to 8 RS-485 readers can be connected, GV-AS4111 only supports control of up to 4 doors.
-

2.2 Connecting Input Devices

Up to 16 input devices can be connected to GV-AS4111 / 8111. Connect the input wires to **IN1~16** and connect GND wires to **GND**. Multiple GND wires can be connected to the same GND pin.

All inputs are **dry contact** that can be configured as normally open (NO) or normally closed (NC) on the Web interface. You can change the input status through the Controller's Web interface.

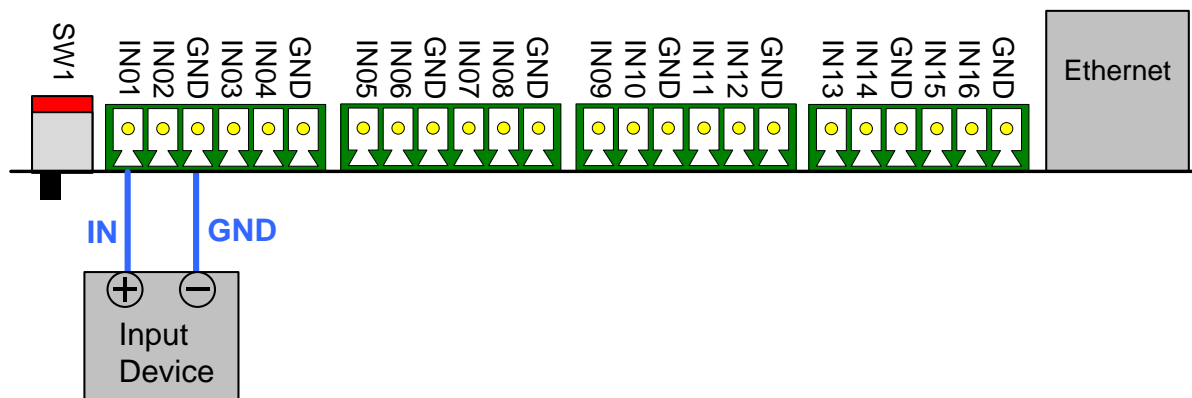

Figure 4

2.3 Connecting Output Devices

Up to 24 output devices can be connected to GV-AS4111 / 8111. Check if your output device meets the following absolute maximum ratings before connecting it to output terminal block.

Outputs	Outputs 1-16	Outputs 17-24
Breakdown Voltage	30V DC	30V DC
Continuous Load Current	3A	1A
<p>Note: Absolute Maximum Ratings are those values beyond which damage to GV-AS4111 / 8111 circuit board may occur. Continuous operation at the absolute rating level may affect GV-AS4111 / 8111's stability.</p>		

To connect an output device:

Connect the (+) point on the output device to COM on GV-AS4111 / 8111, connect the two (-) points of the output device and the power supply together, and connect the (+) point on the power supply to the NO or NC of GV-AS4111 / 8111 based on the state of the output device.

There are two ways to supply power to the output device:

- **Use the power outputs on the GV-AS Controller:** The total power consumption of the output devices and readers connected to GV-AS Controller must be under **3.5A** for GV-AS4111 or **5A** for GV-AS8111. The output device must be a 12V device.
- **Connect an external power supply:** Connect an external power supply if the total power consumption exceeds 3.5A / 5A or if the output device requires higher current.

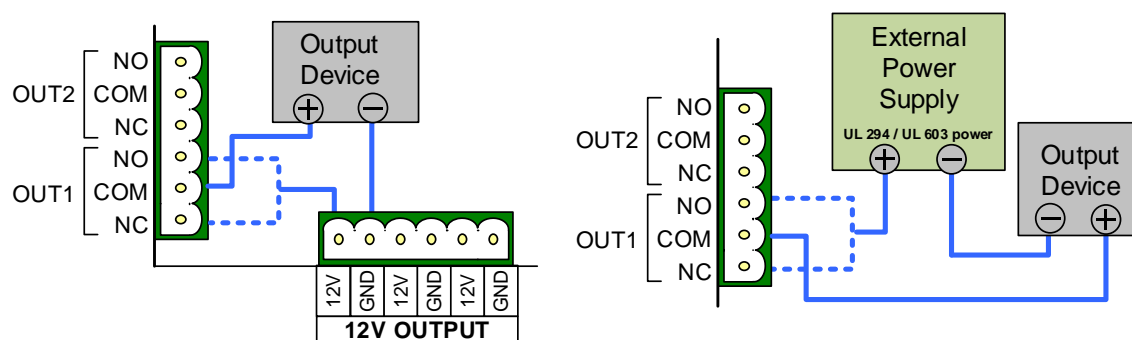

Figure 5

Note: If you want to use the power outputs on the GV-AS Controller, note that the maximum current of the voltage output is 12V, 0.5A.

2.4 Connecting Backup Battery

You can connect any 12V battery to GV-AS4111 / 8111 to provide backup power when the main power supply fails. When the main power supply is removed and the battery voltage level is above 10.2V, the Discharging LED will light and the battery will support normal operation of the GV-AS4111 / 8111.

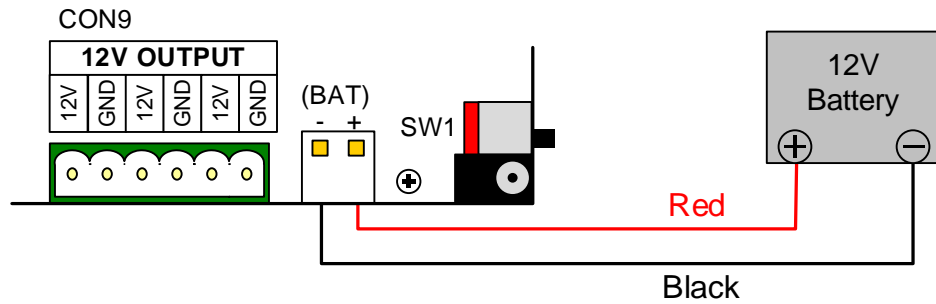

Figure 6

2.5 Connecting the Power

You can connect GV-AS4111 / 8111 to power directly using the supplied 12V DC adaptor. After power is connected, the power LED on GV-AS4111 / 8111 should glow.

Note: Power should only be applied to the unit when all connections are completed and tested.

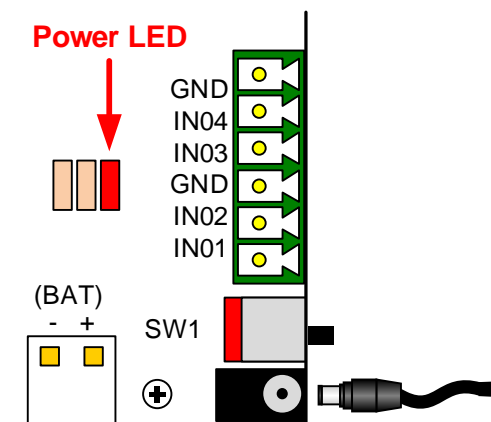
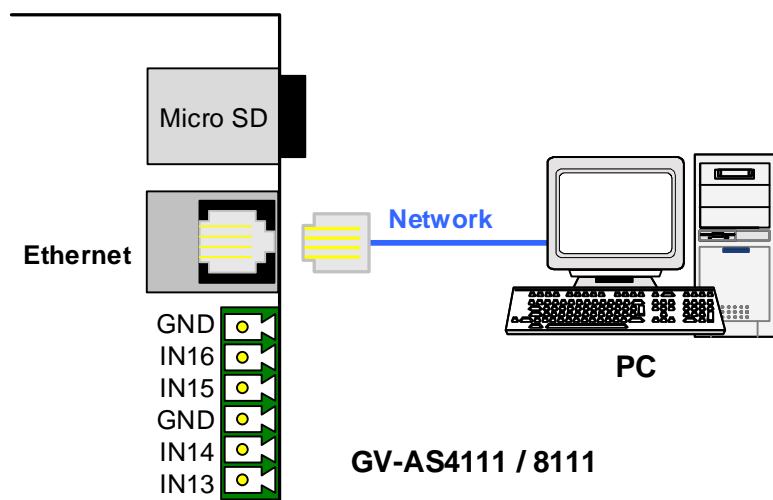

Figure 7

2.6 Connecting the PC

Connecting GV-AS4111 / 8111 to a computer allows you to access its Web interface and connect it to GV-ASManager if the computer is installed with GV-ASManager. The computer running GV-ASManager software can be used to monitor the access information and alarm messages from GV-AS4111 / 8111. If connection with GV-ASManager is interrupted, GV-AS4111 / 8111 kit stores this information on the supplied micro SD card. The data stored will be sent to GV-ASManager when connection resumes.



Minimum System Requirements		
OS	32-bit	Windows XP / Vista / 7 / 8 / Server 2008
	64-bit	Windows XP / Vista / 7 / 8 / Server 2008 / Server 2012
CPU	Core 2 Duo E8400, 3.0 GHz	
Memory	2 x 1 GB Dual Channels	
Hard Disk	500 GB	
VGA	AGP or PCI-Express, 1280 x 1024, 32-bit color and support DirectX 10	
DirectX	End-User Runtimes (November 2008)	
Software	.NET Framework 3.5 SQL Server 2005 Express (optional)	
Browser	Internet Explorer 7.0 or later	

Figure 8

Note:

1. GV-AS4111 / 8111 is only compatible with GV-ASManager V4.2.3 or later.
 2. Data processing equipment and office appliance and business equipment used as computer equipment shall comply with the Standard for Information Technology Equipment - Safety - Part 1: General Requirements, UL 60950-1.
 3. The product shall be provided supply line transient protection complying with the Standard for Transient Voltage Surge Suppressors, UL 1449, with a maximum marked rating of 330 V.
 4. The product shall be provided signal line transient protection complying with the requirements for the Standard for Protectors for Data Communication and Fire Alarm Circuits, UL 497B, with the maximum marked rating of 50 V.
 5. The product shall be provided that communication circuits and network components connected to the telecommunications network shall be protected by secondary protectors for communication circuits. These protectors shall comply with the Standard for Secondary Protectors For Communication Circuits, UL 497A. These protectors shall be used only in the protected side of the telecommunications network.
 6. The equipment shall be installed in a temperature controlled environment. A temperature controlled environment is defined as one that can be maintained between 13 - 35°C (55 - 95°F) by the HVAC system. Twenty-four hours of standby power shall be provided for the HVAC system. The standby power system for the HVAC system may be supplied by an engine driven generator alone. A standby battery is not required to be used.
-

3 Other Settings

3.1 Web Setting Switch

When the **Web Setting** switch is set to the ON position, you can modify **Advanced Settings** and **Extended Reader** settings of GV-AS4111 / 8111 through its Web interfaces. When the switch is set to the OFF position, Advanced Settings and Extended Reader settings are not accessible.

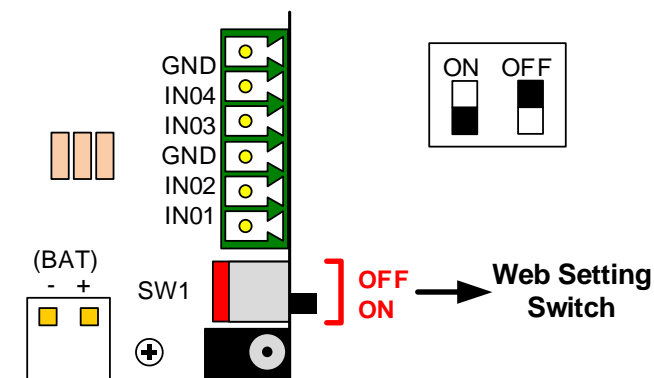

Figure 9

3.2 Resetting the GV-AS4111 / 8111

To reset GV-AS4111 / 8111, press the **Reset** button on the right side of GV-AS4111 / 8111 circuit board for three seconds.

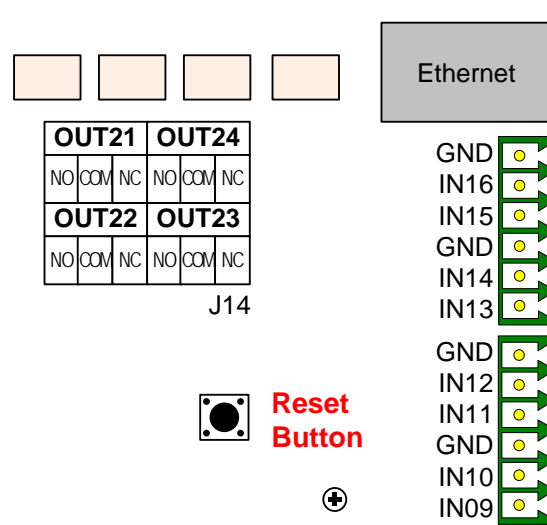

Figure 10

3.3 Restoring Factory Defaults

To restore GV-AS4111 / 8111 to factory default settings, press the **Default** button for 10 seconds.

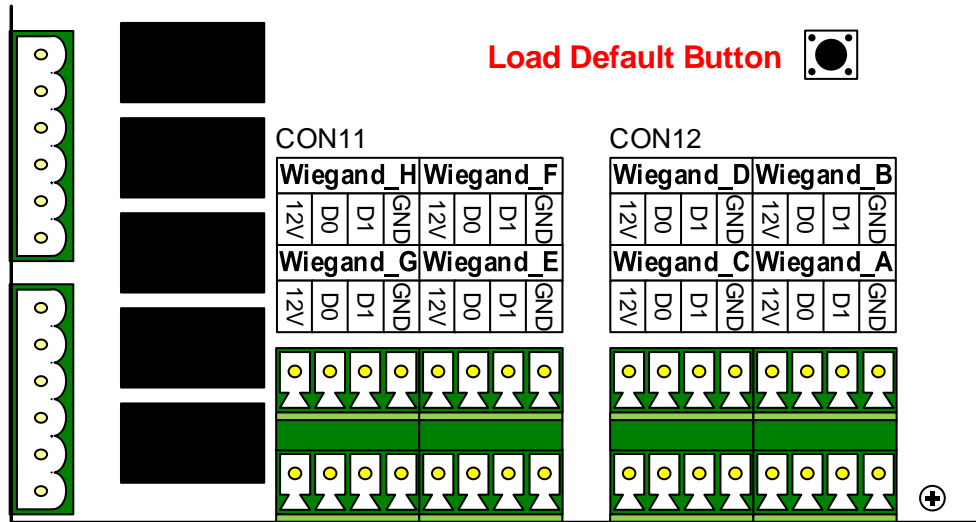

Figure 11

4 GV-AS4111 / 8111 Kit

GV-AS4111 / 8111 Kit is a cabinet containing a GV-AS4111 or GV-AS 8111, a power adapter board, a power supply and a casing for backup battery. The power supply provides power to GV-AS4111 / 8111 and up to 8 output devices (12V, 0.5A per device).

4.1 Packing List

- GV-AS4111 Kit / GV-AS 8111 Kit
- Iron box key
- Iron box screw x 6
- Self-adhesive cable tie mounts x 6
- Battery wiring
- Micro SD Card 2 GB
- Software CD
- Warranty Card

4.2 GV-AS4111 / 8111 Kit Overview

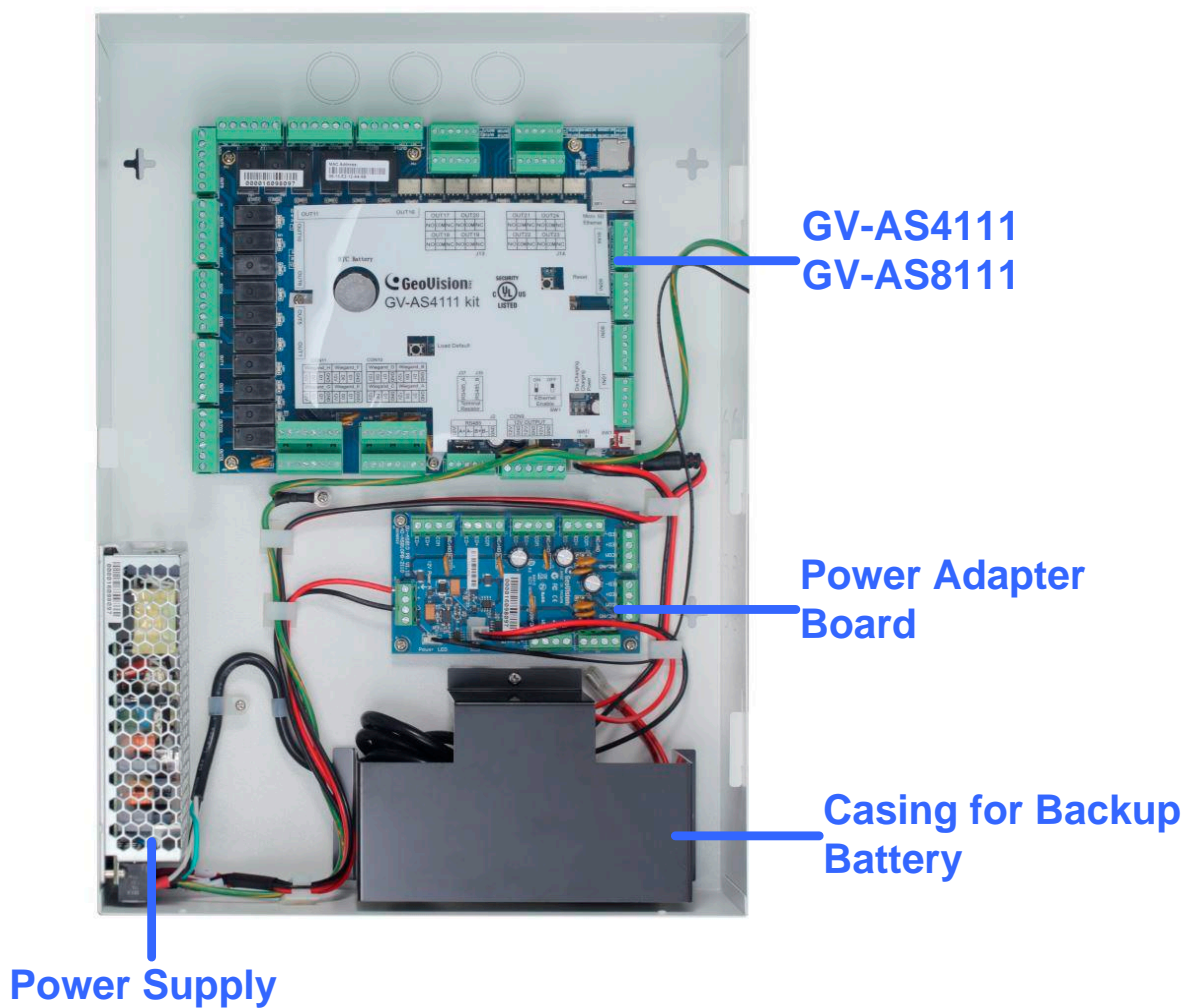

Figure 12

4.3 GV-AS4111 / 8111 Kit Standard Application

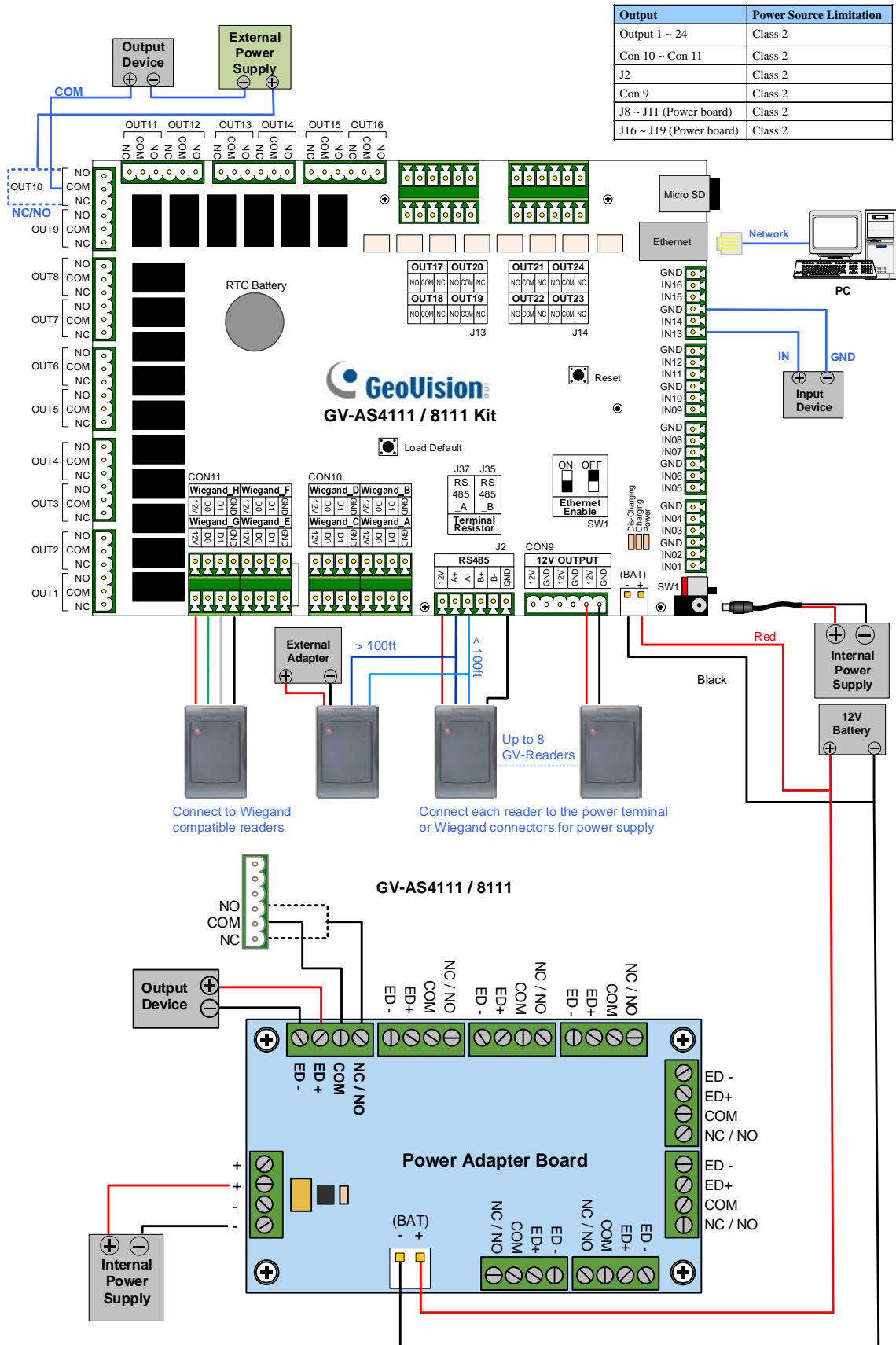

Figure 13

4.4 Connecting the GV-AS4111 / 8111 Kit

Up to 8 output devices can be powered by the power adapter board. Connect each output device to one terminal block on the board.

1. Connect the **COM** pin on GV-AS4111 / 8111's output terminal block to the corresponding pin on the power adapter board. Connect the **NC / NO** pins according to the state of the output device.

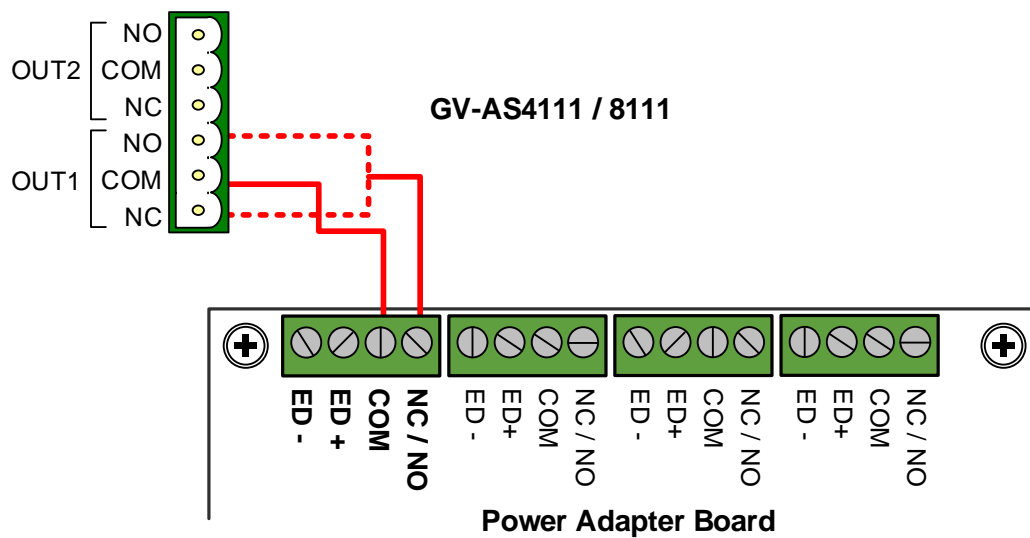

Figure 14

2. Connect the **ED + / -** pins to the (+) and (-) points on the output device (ex: electric lock).

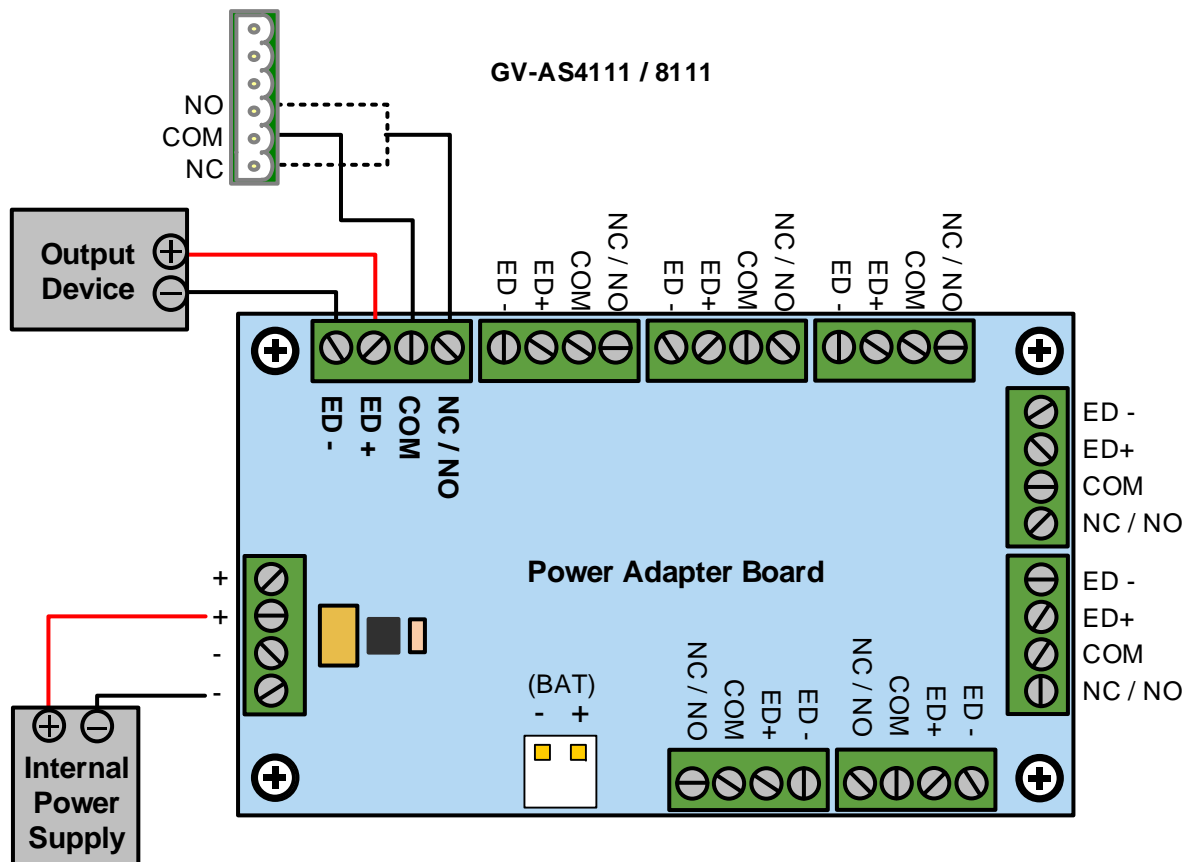

Figure 15

3. When all connections are completed, connect the power supply to a 110-120V power source.

Note:

1. The power supply of GV-AS4111 / 8111 Kit comes in US standard, UL standard, and EU standard. Make sure the device is connected with a voltage within its voltage range.
2. You can place a backup battery in the supplied battery casing, and connect the backup battery to the GV-AS4111 / 8111 board. Refer to *2.4 Connecting Backup Battery* for details.

4.5 GV-AS4111 / 8111 Kit Specifications

Power Adapter Board

Output	DC Voltage Range	12V
	Rated Current	0.5A
	Rated Power	6 W
Number of connectors	Input	2
	Output	8
Wire Size (AWG)		12 ~ 22

Power Supply

Output	DC Voltage Range	11V ~ 13V (Nominal 12V)
	Rated Current	13A
	Rated Power	150 W
Input	US Standard (UL)	110 ~ 120V, 50 Hz / 60 Hz, 1.7 A
	EU Standard	200 ~ 240V, 50 Hz / 60 Hz

GV-AS4111 / 8111 Kit

Dimensions (L x W x H)	420 x 300 x 110 mm / 16.5 x 11.8 x 4.33 in
Weight	4.4 kg / 9.68 lb

5 The Web Interface

You can install GV-AS4111 / 8111 on a network and configure GV-AS4111 / 8111 through its Web interface.

6 GV-AS4111 / 8111 Specifications

Software		
Control Mode	GV-AS4111	GV-AS8111
One-Way Control	4 doors	8 doors
Two-Way Control	4 doors by Wigand, RS-485 and Network	4 doors by Wiegand only 8 doors by RS-485 or Network 8 doors with max 4 doors by Wiegand and other doors by RS-485 / network
Hardware		
CPU	32-bit ARM7TDMI	
Number of User Cards	40,000 cards	
Event Buffer	1,000,000 events and log data	
Power	100 ~ 120V AC, 50 ~ 60 Hz, 1.7A	
RS-485 Interface	1 RS-485 interface	2 RS-485 interfaces
	Up to 8 GV-Readers	Up to 16 GV-Readers
	Distance 600 m (1968.50 ft), 24 AWG, 13V DC min., 85 °C min.	
Wiegand Interface	8 Wiegand interfaces, 26 ~ 64 bit format, distance 100 m (328.1ft), 24 AWG, 13V DC min., 85 °C min.	
TCP/IP Interface	1 TCP/IP interface for GeoVision network readers	
Communication Protocol	TCP/IP	
Battery	Built-in battery, replaceable button cell (CR2032)	
Input	16 inputs, dry contact, NO/NC	
Output	1~16 relay output / 30V DC, 3A 17~24 relay output / 30V DC, 1A CON 10~CON 11, 11~13V DC (Nominal 12V DC), 0.5A J2, 11~13V DC (Nominal 12V DC), 0.5A CON 9, 11~13V DC (Nominal 12V DC), 0.5A J8~J11 & J16~J19, 11~13V DC (Nominal 12V DC), 0.5A	
Operating Temperature	0 ~ 65°C / 32 ~ 149°F	
Operating Humidity	10% ~ 90% RH (non-condensing)	
Dimensions (W X H X D)	210 x 187 x 40 mm / 8.27 x 7.36 x 1.57 in	

Weight	900 g / 2 lb
Certification	UL, CE, FCC, RoHS

Note: The system is evaluated for the following performance levels:

Type of Approval	
Feature	Level
Destructive Attack	1
Line Security	1
Endurance	1
Standby Power	1

All specifications are subject to change without notice.