

GV-RK1352 / R1352 / DFR1352 Reader

Installation Guide



Before attempting to connect or operate this product, please read these instructions carefully and save this manual for future use.



© 2016 GeoVision, Inc. All rights reserved.

Under the copyright laws, this manual may not be copied, in whole or in part, without the written consent of GeoVision.

Every effort has been made to ensure that the information in this manual is accurate. GeoVision, Inc. makes no expressed or implied warranty of any kind and assumes no responsibility for errors or omissions. No liability is assumed for incidental or consequential damages arising from the use of the information or products contained herein. Features and specifications are subject to change without notice.

Note: No memory card slot or local storage function for Argentina.

GeoVision, Inc.
9F, No. 246, Sec. 1, Neihu Rd.,
Neihu District, Taipei, Taiwan
Tel: +886-2-8797-8377
Fax: +886-2-8797-8335
<http://www.geovision.com.tw>

Trademarks used in this manual: *GeoVision*, the *GeoVision* logo and GV series products are trademarks of GeoVision, Inc. *Windows* and *Windows XP* are registered trademarks of Microsoft Corporation.

June 2016

Contents

GV-RK1352 / R1352 / DFR1352 Card Reader	1
1. Physical Descriptions	3
1.1 Electric Wire.....	3
1.2 Keypad (GV-RK1352 Only)	5
1.3 LED Indicator and Beeper.....	5
2. Connecting the Reader to GV-AS Controller.....	6
2.1 Connecting through Wiegand Interface.....	7
2.2 Connecting through RS-485 Interface.....	7
2.2.1 Defining Readers on GV-AS Controller Web Interface.....	9
3. Installing the GV-R/RK/DFR Config AP.....	11
4. Overlaying Card Numbers on GV-System Live View	12
4.1 Defining the ID Number and Setting the Reader to Slave.....	12
4.2 Adding the Reader to GV-System.....	14
5. Changing the Default Settings of Beeper and LED.....	15
5.1 Setting up Beeper and LED on GV-R/RK/DFR Config AP.....	15
5.2 Wiring the Beeper and LED to the GV-AS Controller.....	17
5.3 Configuring the Beeper and LED Settings for Each Door/Gate.....	18
6. Setting UID or GID on GV-R/RK/DFR Config AP	19
7. Firmware Upgrade.....	21
8. Specifications.....	22
9. Mounting Method for the Readers	23
9.1 Standard Mount for the Readers.....	23
9.2 Optional Mount for GV-RK1352 Card Reader.....	25

GV-RK1352 / R1352 / DFR1352 Card Reader

The content of this installation guide refers to the following readers:

- GV-RK1352 firmware V1.2
- GV-R1352 firmware V1.2
- GV-DFR1352 (Rev. B) firmware V1.2

Introduction

GV-RK1352 / R1352 / DFR1352 are card readers capable of recognizing identification cards. GV-RK1352 comes with keypad, allowing it to also recognize PIN codes. GV-DFR1352 is designed to be installed on the door frame.

Featured with the Wiegand and RS-485 outputs, the readers can be connected to GV-AS series control panel. The readers are protected by a weather sealed and IP66 compliant housing for outdoor use.

Packing List

GV-RK1352



1. GV-RK1352 Card Reader
2. Screw x 2
3. Screw Anchor x 2
4. Front Cover Plate x 1



5. Software CD
6. Warranty Card
7. Installation Guide
8. Connection plug with the stand-alone power adapter (Optional)

GV-R1352



1. GV-R1352 Card Reader
2. Screw x 3
3. Screw Anchor x 2
4. Security Torx
5. Software CD
6. Warranty Card
7. Installation Guide
8. Connection plug with the stand-alone power adapter (Optional)

GV-DFR1352



1. GV-DFR1352 Card Reader
2. Screw x 2
3. Screw Anchor x 2
4. Front Cover Plate x 2
5. Software CD
6. Warranty Card
7. Installation Guide
8. Connection plug with the stand-alone power adapter (Optional)

1. Physical Descriptions

1.1 Electric Wire

GV-RK1352

Wire Color	Function
Red	DC 7.5 ~ 12 V
Black	GND
Yellow	Beeper
Orange	Green LED
Light Red	Red LED
Green	Wiegand Data 0
White	Wiegand Data 1
Blue	RS-485 +
Light Blue	RS-485 -

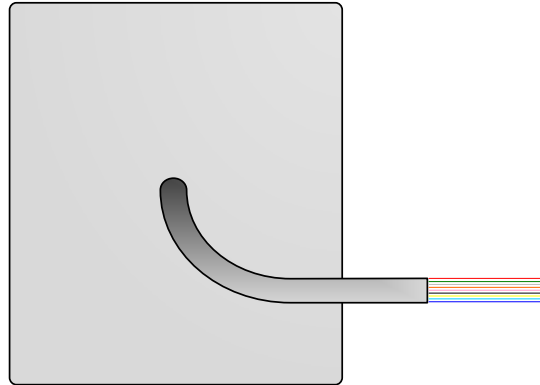

Rear View

GV-R1352

Wire Color	Function
Red	DC 7.5 ~ 12V
Black	GND
Yellow	Beeper
Orange	Green LED
Light Red	Red LED
Green	Wiegand Data 0
White	Wiegand Data 1
Blue	RS-485 +
Light Blue	RS-485 -
Gray	N/A
Purple	N/A
Brown	N/A

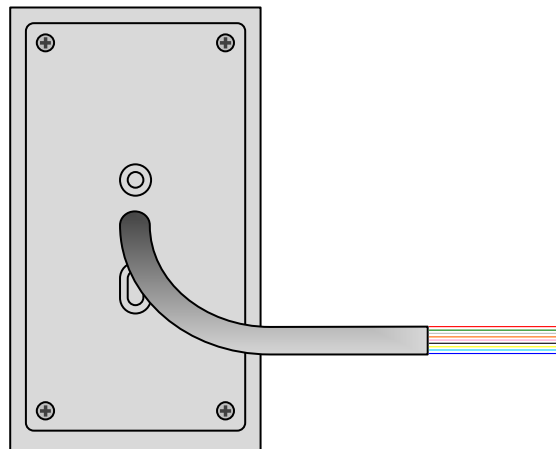

Rear View

GV-DFR1352

Wire Color	Function
Red	DC 7.5 ~ 12V
Black	GND
Yellow	Beeper
Orange	Green LED
Light Red	Red LED
Green	Wiegand Data 0
White	Wiegand Data 1
Blue	RS-485 +
Light Blue	RS-485 -
Gray	N/A
Purple	N/A
Brown	N/A

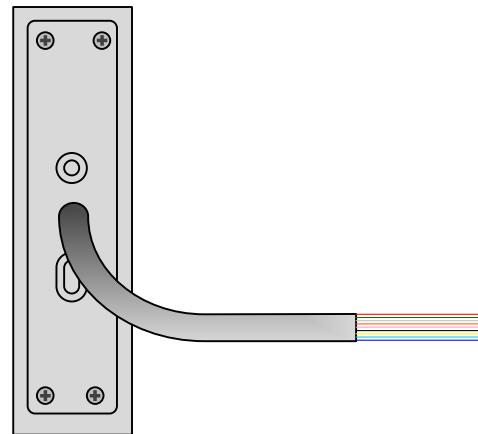

Rear View

Install the GV-DFR1352 to the door frame using the supplied screws and screw anchors. Before placing and sticking the front cover plate to the GV-DFR1352, remove the Plastic Cover to prevent scratches to the cover after installed.

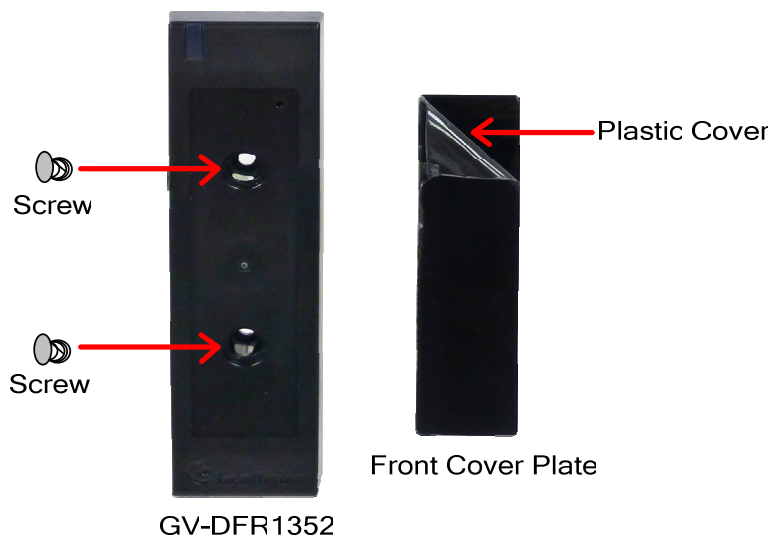

1.2 Keypad (GV-RK1352 Only)

When accessing an entry using GV-RK1352, you can enter the door's PIN code on the keypad or present the card and then enter the card's PIN code on the keypad to be granted access. The access mode is defined on GV-ASManager.

1. **0~9 Number Keys:** Press the number keys to enter the PIN code.
2. **# Key:** Press the # key to confirm the PIN code.
3. *** Key:** Press the * key to cancel the PIN code.

1.3 LED Indicator and Beeper

In standby mode, the LED is blue. When a card is read, the LED flashes green and the beeper beeps once.

The reader comes with external control wires for Green LED, Red LED and Beeper. You can connect these control wires to GV-AS4111 Kit / 8111 Kit to change the default settings of the LED and Beeper. For details on how to configure the settings, refer to *5. Changing the Settings of Beeper and LED* later in this installation guide.

2. Connecting the Reader to GV-AS Controller

You can connect the readers to GV-AS Controllers through Wiegand or RS-485 interface. Note that the connection between the reader and GV-AS Controller varies with different controller models. To see how many readers can be connected to a GV-AS Controller, refer to *The Number of Readers Supported by GV-AS Controllers* table at the end of this installation guide.

Note:

1. GV-RK1352 / R1352 / DFR1352 is compatible with GV-AS Controllers. However, to enable the keypad function on GV-RK1352, you can only connect GV-RK1352 to the controllers through Wiegand or RS-485 interface
2. Each GV-RK1352 / R1352 / DFR1352 consumes 60 mA of power. The total power consumption of the output devices and readers connected to the GV-AS Controller must be under **3.5A** for GV-AS4111 Kit or **5A** for GV-AS8111 Kit. Connect an external power supply if the power supplied from GV-AS Controller is insufficient.
3. Connecting method of external power supply is as below:
 - a. Plug in the ferrous type cord to the external power supply.
 - b. Connect ferrous type cord to the card reader. (The wiring methods shall be in accordance with the National Electrical Code, ANSI/NFPA 70.)



2.1 Connecting through Wiegand Interface

The following diagrams show the connection between **GV-RK1352** and **GV-AS8111 Kit / 4111 Kit**. Up to eight readers can be connected to GV-AS8111 Kit / 4111 Kit through the controller's Wiegand interface.



2.2 Connecting through RS-485 Interface

The following diagrams show the connection between **GV-RK1352** and **GV-AS8111 Kit / 4111 Kit**. Up to eight readers can be connected together to the RS-485 interface on **GV-AS8111 Kit / 4111 Kit**.

- Connecting four or less readers to GV-AS8111 Kit / 4111 Kit.:

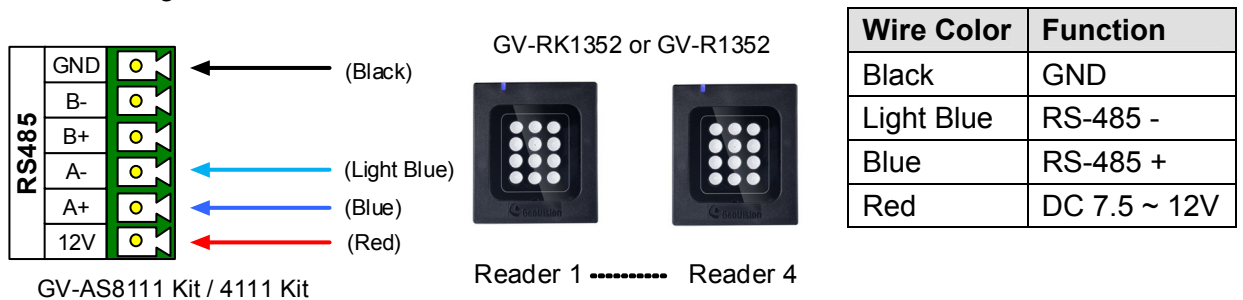

- Connecting five or more readers to GV-AS8111 Kit / 4111 Kit:
For readers five to eight, connect the RS-485 cable to the RS-485 interface on GV-AS8111 Kit / 4111 Kit and then connect the 12V power output and GND of the reader to a 12V DC power output on the controller.

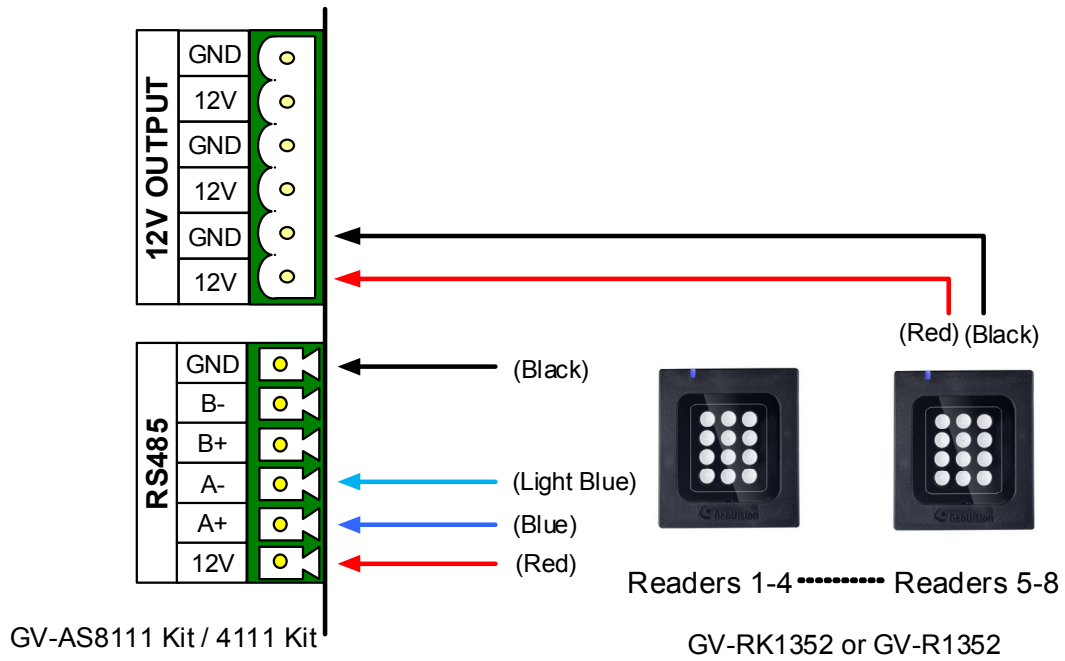

Note:

1. For RS-485 connection between GV-AS Controllers and readers, use additional power for the readers when the distance ranges from 30.48 meters ~ 600 meters (100 ft ~ 1968.50 ft). There is no need to use additional power when the distance is within 30.48 meters (100 ft).
2. Recommended power supply:

Manufacturer	Model	Output rating
Powertron	PA1015-2I	12V, 1.25A, 15W Max

2.2.1 Defining Readers on GV-AS Controller Web Interface

Since multiple readers can connect to GV-AS Controller using one RS-485 interface, you need to specify which door each reader controls. This section explains how to define readers on the Web interface of GV-AS Controller. On the Web interface, you can also set the reader to read the GID or UID on GV-AS ID Cards / Key Fobs. Note that the Web interface of different GV-AS Controller models varies.

1. On the controller's Web interface, click **Extended Reader**. This dialog box appears.

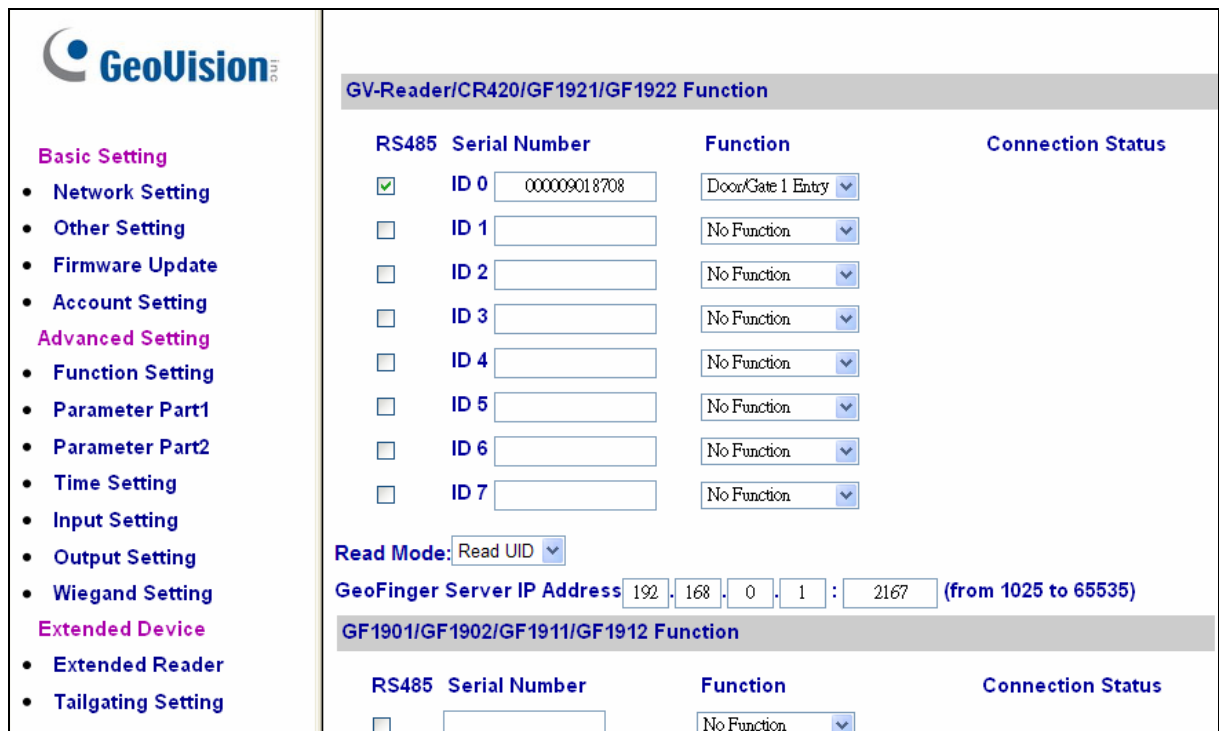

RS485	Serial Number	Function	Connection Status
<input checked="" type="checkbox"/>	ID 0 000009018708	Door/Gate 1 Entry	
<input type="checkbox"/>	ID 1	No Function	
<input type="checkbox"/>	ID 2	No Function	
<input type="checkbox"/>	ID 3	No Function	
<input type="checkbox"/>	ID 4	No Function	
<input type="checkbox"/>	ID 5	No Function	
<input type="checkbox"/>	ID 6	No Function	
<input type="checkbox"/>	ID 7	No Function	

Read Mode: Read UID

GeoFinger Server IP Address 192.168.0.1 : 2167 (from 1025 to 65535)

RS485	Serial Number	Function	Connection Status
<input type="checkbox"/>		No Function	

2. In the GV-Reader/CR420/GF1921/GF1922 section, select the **RS485** checkbox in front of the ID number and type the **Serial Number** on the rear panel of the reader. The ID number will be assigned to the reader.

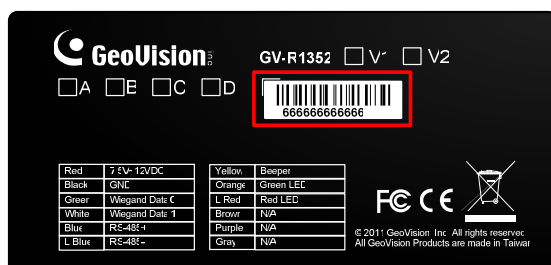

3. Select a door/gate for the reader from the **Function** drop-down list.
4. Next to **Read Mode**, select **Read UID** or **Read GID** to set the connected readers to read UID (unique identifier) or GID (GeoVision ID) on GV-AS ID Cards / Key Fobs.

If you select **Read GID**, make sure there are two numbers on your GV-AS ID Cards / Key Fobs as shown below. If there is only one number on your GV-AS ID Cards / Key Fobs, GID is not supported, and you must select Unique Identification (UID).

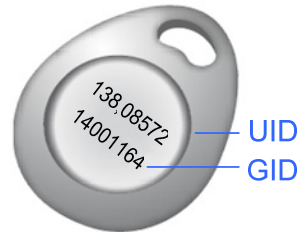
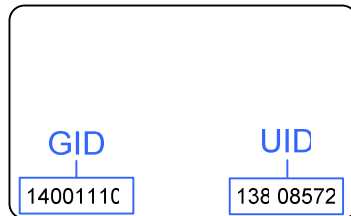

5. Click **Submit**.

Note:

1. When you click **Submit** on the Extended Reader page of a GV-AS8111 Kit / 4111 Kit, all readers connected through RS-485 interface will reboot.
2. GID ID format is only supported in GV-RK1352 / GV-R1352 / GV-DFR1352 (Rev. B) V1.2 or later.
3. If you are using third-party cards or key fobs, you must set the reader to read UID.

3. Installing the GV-R/RK/DFR Config AP

The GV-R/RK/DFR Config AP allows you to set the reader's beeper / LED, ID number, master / slave status, and whether it reads UID or GID. When using the Config AP, the reader needs to be connected to a PC through GV-COM, GV-Hub or GV-NET/IO Card V3.1.

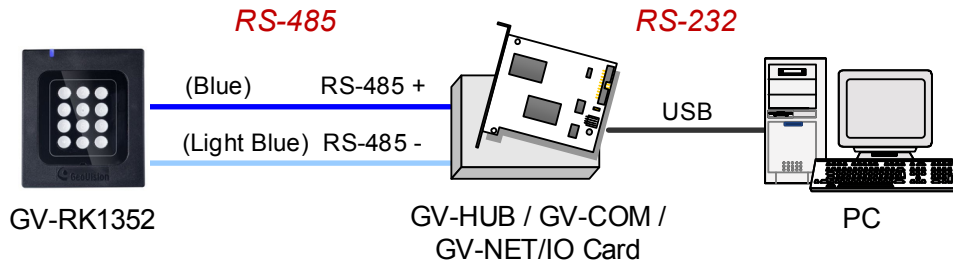

You can install the Config AP from the Software DVD or GeoVision Website. To use a GV-COM, GV-Hub or GV-NET/IO Card V3.1, you also need to install GeoVision USB Device Driver.

Installing from Software CD

1. Insert the software CD and the Install Program window will pop up automatically.
2. Select **Install GeoVision USB Device Driver**.
3. In the GeoVision USB Driver Installer window that appears, select **Install**.
4. Go back to the Install Program window, and select **Run GV-Reader Config Utility**.

Downloading from GeoVision Website

1. Go to the Software Download and Upgrading page of GeoVision Website:
http://www.geovision.com.tw/english/5_8_AS.asp
2. Select **GV-Reader** from the drop-down list, and click the **Download** icon  of **GV-RK1352 & GV-R1352 & GV-DFR1352 Config Utility**.

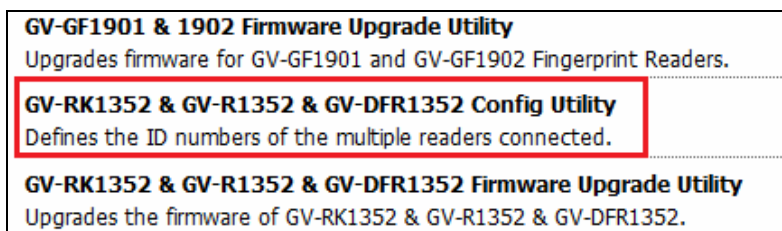

3. Select **Driver** from the drop-down list and click the **Download** icon  of **GV-USB Device Driver**.

4. Overlaying Card Numbers on GV-System

Live View

You can overlay card numbers recognized at the reader onto a camera channel on GV-System. To overlay card numbers on GV-System channel, the reader needs to be connected to a GV-System through GV-COM, GV-Hub or GV-NET/IO Card V3.1.

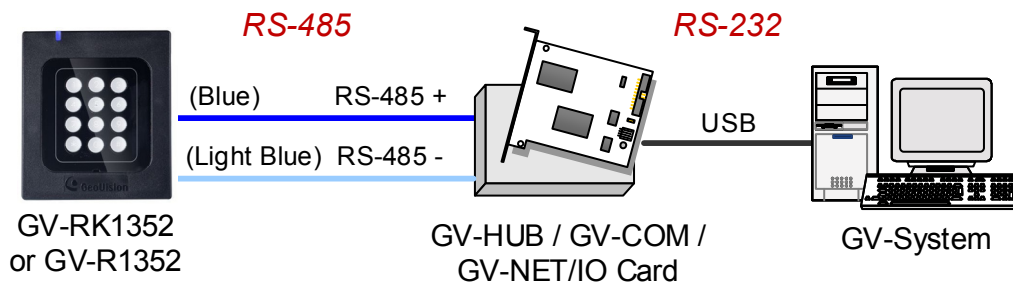

Note: GV-RK1352 / R1352 / DFR1352 is not compatible with GV-NET Card and GV-NET/IO Card of versions earlier than V3.

4.1 Defining the ID Number and Setting the Reader to Slave

After the reader is connected to the computer of the GV-System, use the **GV-R/RK/DFR Config AP** to define the ID number of the reader and set the reader to Slave.

1. Run **GV-R/RK/DFR Config AP**. Refer to 3. *Installing the GV-R/RK/DFR Config AP* above for how to install.

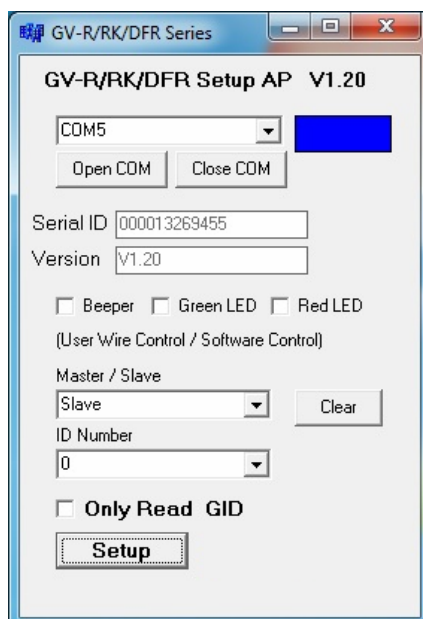

2. Select the COM port that is connected to the reader and click **Open COM**. The serial number and firmware version of the reader will be automatically detected. The red square next to the COM port box should change to blue to indicate the COM port is correct.
3. Under **Master / Slave**, set the reader to **Slave**.
4. Select an **ID number** for the reader. The ID number ranges from 0 to 7.
5. Click **Setup**. The settings are sent to the reader.

If you want to connect multiple readers to the GV-System, you need to set up a unique ID number for each reader. For this you need to connect each reader to the computer one reader at a time, and follow the instructions above to set up an ID number.

Note:

1. If the COM port is incorrect, an “**Error opening serial port**” message will appear. To verify the COM port that is connected to the reader, go to Windows Device Manager. In the Ports (COM & LPT) field, you should see the entry for **Prolific USB-to-Serial Comm Port** and the COM number currently in use.

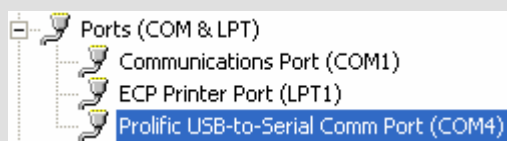

2. If you are using an older version of the Config AP, you will have to manually type the serial number of the reader. The serial number is on the rear panel of the reader.

4.2 Adding the Reader to GV-System

1. In GV-System, click the **Configure** button, select **Accessories**, and select **GV Wiegand Capture Device Setting**. This dialog box appears.

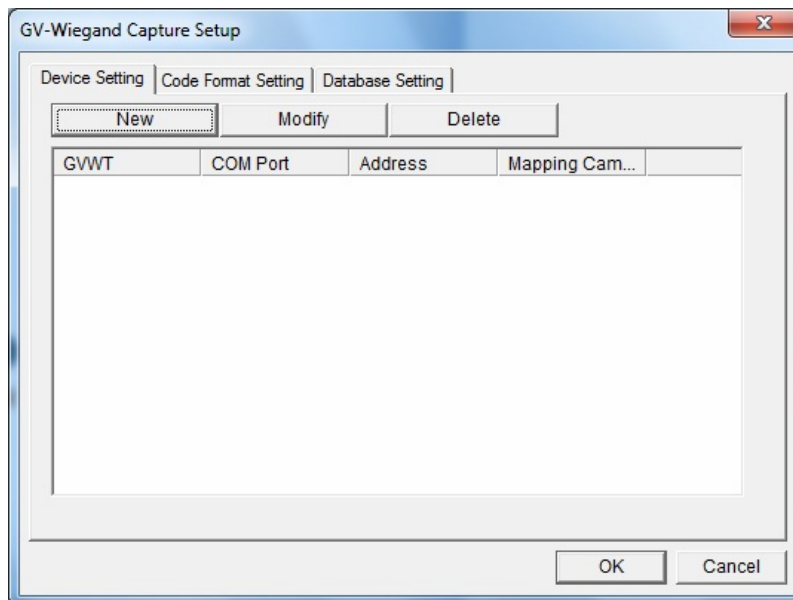

2. Click the **New** button. This dialog box appears.

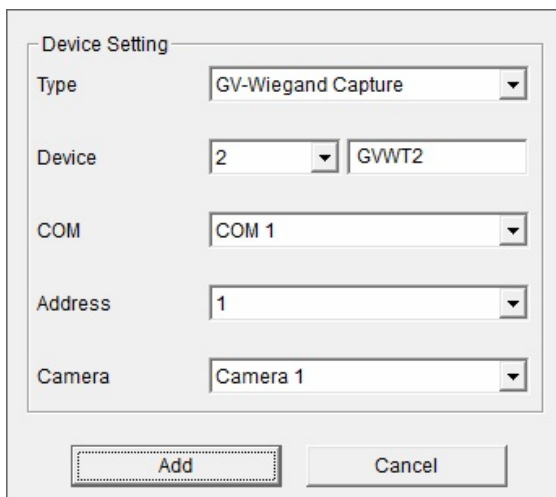

- **Type:** Select GV-Wiegand Capture.
 - **Device:** Type a number and name to help you identify the reader.
 - **COM:** Select the COM port connected to the reader.
 - **Address:** Select the ID of the connected reader you set in GV-R/RK/DFR Config AP.
 - **Camera:** Assign the reader to a channel to overlay card numbers on the live view.
3. Click the **Add** button.

5. Changing the Default Settings of Beeper and LED

You can change the default settings of the LED and the beeper by enabling a GV-AS8111 Kit / 4111 Kit to externally control the LED and Beeper. Through the Web interface, you can set the controller to trigger the red LED, green LED or beeper when the specified alarm events occur.

The GV-AS Controller and the reader need to be connected through Wiegand interface. You will have to:

1. Enable external control of the reader's Beeper and LED by using the **GV-R/RK/DFR Config AP**.
2. Wire the Beeper, Red LED and Green LED from the reader to the GV-AS Controller.
3. Specify the Beeper and LED settings for each door through the Web interface of GV-AS Controller.

5.1 Setting up Beeper and LED on GV-R/RK/DFR Config AP

To enable the external controls of the Beeper and LED on GV-R/RK/DFR Config AP, the reader needs to be connected to a computer through GV-COM, GV-Hub or GV-NET/IO Card V3.1.

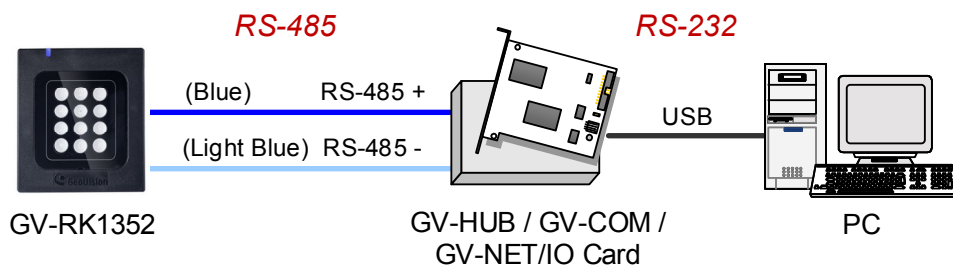

1. Start the **GV-R/RK/DFR Config AP** and select the COM port that is connected to the reader.

Note: To see how to install the Config AP and how to identify the COM port of the reader, refer to *3. Installing GV-R/RK/DFR Config AP* and *4.1 Defining the ID Number and Setting the Reader to Slave* earlier in this installation guide

2. Click **Open COM**. The serial number and the firmware version of the reader will be automatically detected.

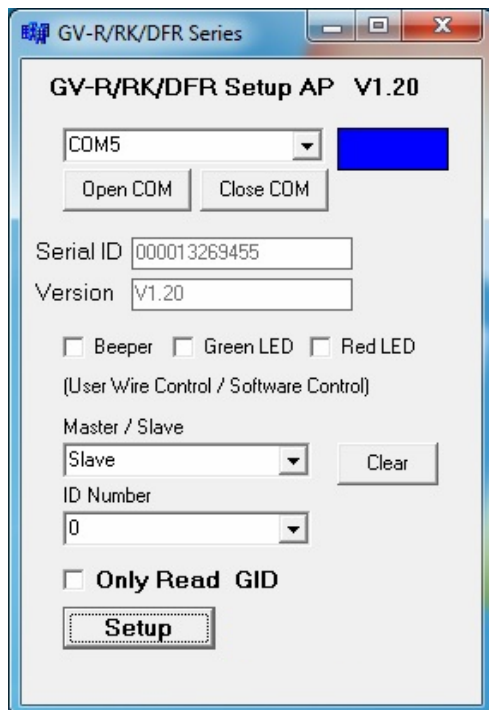

3. To enable external control of Beeper or LED, select **Beeper**, **Green LED** or **Red LED**.
4. Select **Master** from the Master / Slave drop-down list.
5. Select an ID number for the reader. Make sure the ID number on the Config AP matches the ID number set on the Extended Reader page of the GV-AS Controller Web interface.
6. Click **Setup**. The settings are sent to the reader.

If you want to set up multiple readers to be controlled by the controller, you need to connect each reader to the computer one reader at a time, and follow the above instructions to enable external control.

After the above settings, you need to connect the Beeper, Red LED and Green LED wires from the reader to the outputs of GV-AS Controller.

5.2 Wiring the Beeper and LED to the GV-AS Controller

To wire the beeper and LED to GV-AS8111 Kit / 4111 Kit, connect the control wires of the reader's Beeper, Red LED or Green LED to any of the outputs on GV-AS Controller.

Wiring LED to GV-AS Controller

The diagram below shows the connection for wiring Green LED using GV-RK1352 and GV-AS8111 Kit / 4111 Kit. For Red LED, use the light red wire instead.

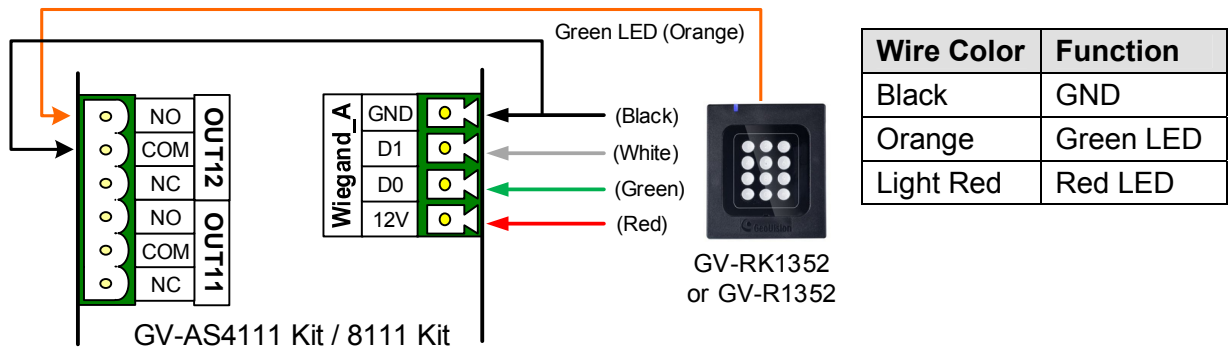

Wiring Beeper to GV-AS Controller

The diagram below shows the connection for wiring the beeper using GV-RK1352 and GV-AS8111 Kit.

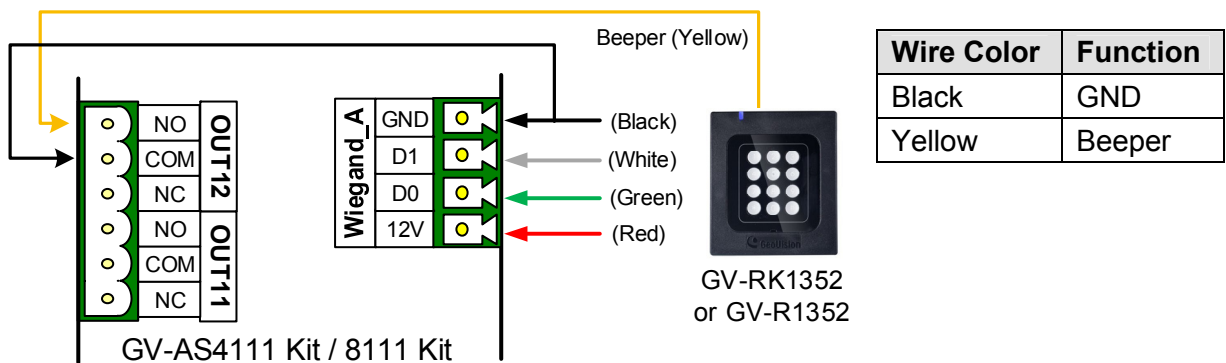

After wiring, you also need to go to GV-ASManager to select the alarm conditions that will set off the reader's beeper. In GV-ASManager, right-click the GV-AS Controller in the device list, click **Settings**, and click the **Door / Gate** tab to select the alarm conditions.

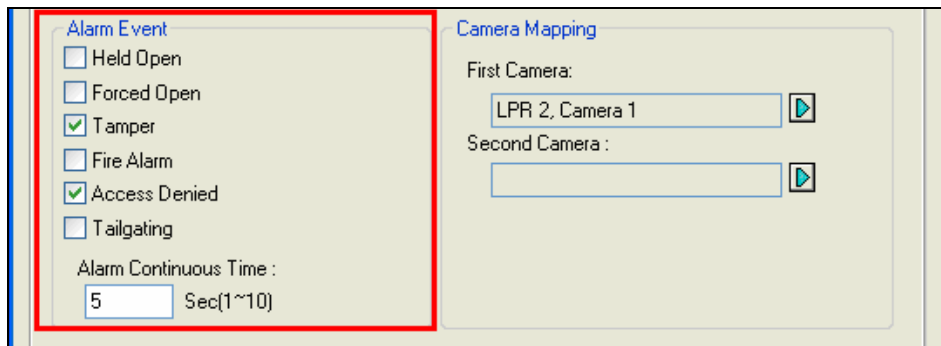

5.3 Configuring the Beeper and LED Settings for Each Door/Gate

After connecting the wires for beeper or LED, specify the conditions to trigger the beeper and LED on the GV-AS8111 Kit / 4111 Kit Web interface.

1. On the controller Web interface, click **Output Setting**. The page below appears.

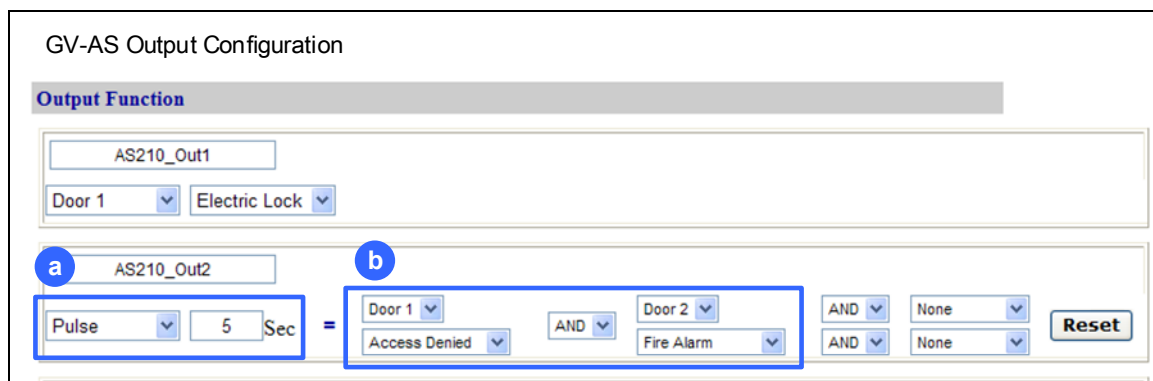

2. Find the output wired to the beeper or LED and specify up to 2 alarm conditions to set off the beeper or LED.
 - a. **Output Type:** Select **Normal**, **Toggle** or **Pulse**. If you select Pulse, you can specify the number of seconds to trigger the beeper or LED.
 - b. **Output Conditions:** Select the door and the alarm conditions to trigger the beeper or LED. Up to 2 sets of output conditions can be set.
3. Click **Submit**.

6. Setting UID or GID on GV-R/RK/DFR Config AP

By default, the readers read the UID (unique identifier) on ID cards or key fobs. Using GV-R/RK/DFR Config AP, you can set the GV-RK1352 / R1352 / DFR1352 to read GID (GeoVision ID) on GV-AS ID Cards / Key Fobs instead.

Note:

1. To see how to install the Config AP and how to identify the COM port of the reader, refer to *3. Installing GV-R/RK/DFR Config AP* and *4.1 Defining the ID Number and Setting the Reader to Slave* earlier in this installation guide
2. GID ID format is only supported in GV-RK1352 / GV-R1352 / GV-DFR1352 (Rev. B) V1.2 or later.
3. If you are using third-party cards or key fobs, you must set the reader to read UID.

1. Run **GV-R/RK/DFR Config AP**.

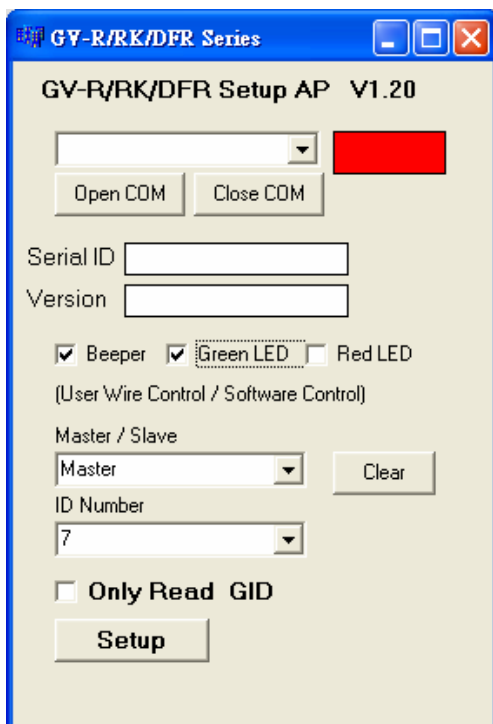

2. Select the COM port that is connected to the reader and click **Open COM**. The serial number and firmware version of the reader will be automatically detected. The red square next to the COM port box should change to blue to indicate the COM port is correct.

3. To set the reader to read GID, select **Only Read GID**.
4. Click **Setup** to apply the setting.

To use GID, make sure there are two numbers on your GV-AS ID Cards / Key Fobs as shown below. If there is only one number on your GV-AS ID Cards / Key Fobs, GID is not supported and you must select Unique Identification (UID).

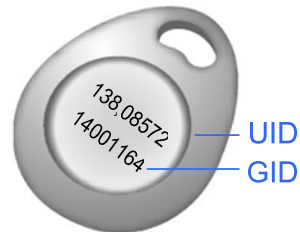
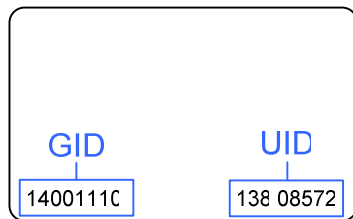

7. Firmware Upgrade

GeoVision will periodically release the updated firmware on the website. The new firmware can be simply loaded into the reader by using **Update Utility** included in the Software CD.

Important Notes before You Start

Before you start updating the firmware, please read these important notes:

1. While the firmware is being updated, the power supply must not be interrupted.
2. Do not turn the power off within 10 minutes after the firmware is updated.

WARNING: The interruption of power supply during updating causes not only update failures but also damages to the device. In this case, please contact your sales representative and send your device back to GeoVision for repair.

To upgrade firmware:

1. Insert the Software CD and select **Run Firmware Update Utility**. This dialog box appears.

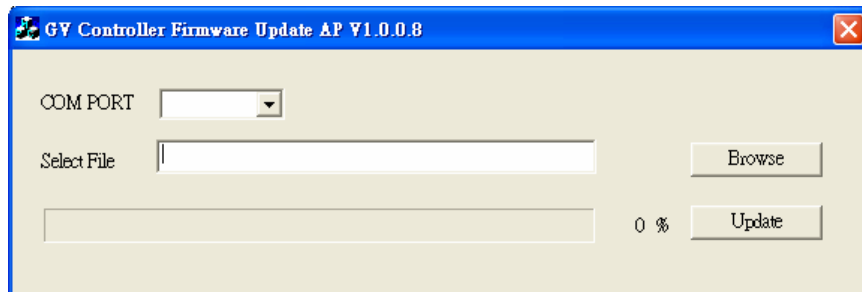

2. Select the COM port of the reader.
3. Click the **Browse** button to locate the firmware file (.bin) saved at your local computer.
4. Click **Update**.
5. The LED indicator should flash purple during the process of firmware upgrading. When the process is complete, the reader will be sounded twice and the LED indicator will change to green.

Note: You can also download the firmware upgrade utility from the GeoVision website: http://www.geovision.com.tw/english/5_8_AS.asp. Select **GV-Reader** from the drop-down list, click the **Download** icon  of **GV-RK1352 & GV-R1352 & GV-DFR1352 Firmware Upgrade Utility**.

8. Specifications

	GV-RK1352	GV-R1352	GV-DFR1352 (Rev. B)
CPU	8-bit microprocessor		
Frequency	13.56 MHz for ISO14443A (Mifare DESFire, Mifare Plus and Mifare Class)		
Input Rating	7.5V DC~12V DC, 200mA		
Wiegand Interface	Wiegand 26 / 34 bit, distance 100 m (328.1ft), 24 AWG, 13V DC min., 85 °C min		
RS-485	9,600 bps, connect up to 8 GV-RK1352 / R1352 / DFR1352 units Distance 600 m (1968.50 ft), 24 AWG, 13V DC min., 85 °C min		
LED	Red, Green and Blue LED		
Beeper	Buzzer		
Reader Color	Black		
Supported ID Formats	Reads GID and UID		
Operating Temperature	-35 °C ~ 66°C / -31 °F ~ 150.8 °F		
Operating Humidity	10% ~ 90% (no condensation)		
Dimensions (W x H x D)	95 x 108 x 23 mm / 3.74 x 4.25 x 0.91 in	65.8 x 115.6 x 20.5 mm / 4.6 x 2.6 x 0.8 in	20.9 x 105.6 x 20.5 mm / 0.8 x 4.2 x 0.8 in
Weight	260 g / 0.57 lb	120 g / 0.26 lb	80 g / 0.17 lb
Ingress Protection	IP66		
Certification	CE, FCC, RoHS, UL, CUL		

Note:

1. GID ID format is only supported in GV-RK1352 / GV-R1352 / GV-DFR1352 (Rev. B) V1.2 or later.
2. UL 294 Attack Class Level 1 depends on other connected equipment.

9. Mounting Method for the Readers

This section covers standard mount for GV-R1352 / RK1352 / DFR1352 and optional mount for GV-RK1352.

9.1 Standard Mount for the Readers

- For GV-RK1352 / DFR1352,
 1. Insert screw anchors to the wall, and screw GV-RK1352 / DFR1352 through the holes A and B.
 2. Align and secure the cover plate to GV-RK1352 / DFR1352.

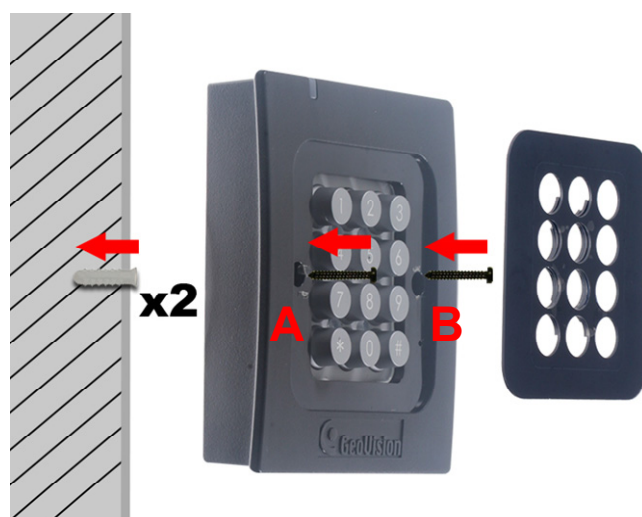

GV-RK1352

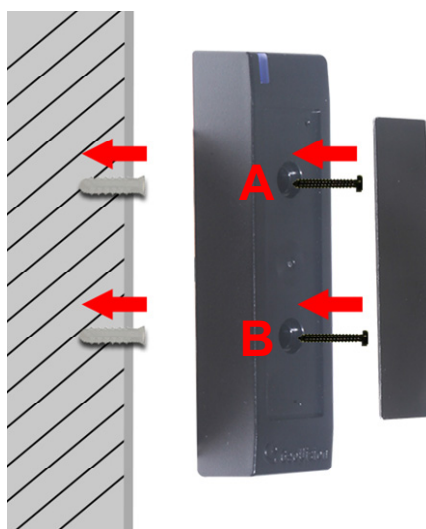

GV-DFR1352

- For GV-R1352,
 1. Insert screw anchors to the wall, and screw GV-R1352 through the holes A and B.
 2. Assemble the box cover to GV-R1352, and secure the cover with the screw using the security torx wrench.

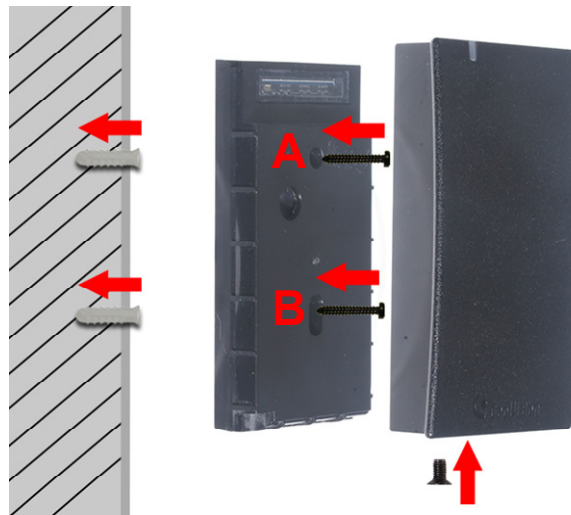

GV-R1352

9.2 Optional Mount for GV-RK1352 Card Reader

Optional accessories can expand the capabilities and versatilities of your GV-RK1352 Card Reader. Consult your sales representative for more information.

GV-MountA900	GV-MountA900 is a mounting plate that allows you to attach GV-RK1352 to a US single gang power box. <ul style="list-style-type: none">• Dimensions: 100 x 68 mm / 3.9 x 2.7 in• Weight: 55 g / 0.12 lb
---------------------	---

Connecting GV-MountA900

Screw GV-MountA900 to the US single gang power box through the hole C and to GV-RK1352 through the hole B as shown below.

