

GV-IP Speed Dome

User's Manual



- GV-SD2322-IR
- GV-SD2722-IR
- GV-SD3732-IR

Before attempting to connect or operate this product, please read these instructions carefully and save this manual for future use.



© 2020 GeoVision, Inc. All rights reserved.

Under the copyright laws, this manual may not be copied, in whole or in part, without the written consent of GeoVision.

Every effort has been made to ensure that the information in this manual is accurate. GeoVision, Inc. makes no expressed or implied warranty of any kind and assumes no responsibility for errors or omissions. No liability is assumed for incidental or consequential damages arising from the use of the information or products contained herein. Features and specifications are subject to change without notice.

Note: No memory card slot or local storage function for Argentina.

GeoVision, Inc.
9F, No. 246, Sec. 1, Neihu Rd.,
Neihu District, Taipei, Taiwan
Tel: +886-2-8797-8377
Fax: +886-2-8797-8335
<http://www.geovision.com.tw>

Trademarks used in this manual: *GeoVision*, the *GeoVision* logo and GV series products are trademarks of GeoVision, Inc.

June 2020

Preface

Welcome to the *GV-IP Speed Dome User's Manual*.

This Manual is designed for the following models and firmware versions:

Model	Model Number	Firmware Version
IP Speed Dome	GV-SD2322-IR	V1.0
	GV-SD2722-IR / GV-SD3732-IR	V1.03

Contents

Naming Definition.....	vi
Note for Connecting to GV-VMS / DVR / NVR	vi
Note for Recording.....	vi
Note for Installing Camera Outdoor	vii
Note for Face Detection	viii
Note for People Counting	ix
Chapter 1 Introduction	1
1.1 Key Features	2
1.2 Packing List	4
1.3 System Requirements.....	5
1.4 Optional Accessories	6
1.5 Physical Description.....	8
1.6 Accessory Installation (Wall Pendant Mount)	9
1.7 Connecting the Camera	13
Chapter 2 Accessing the Camera.....	15
2.1 Installing on a Network.....	15
2.1.1 Checking the Dynamic IP Address.....	16
2.1.2 Assigning an IP Address.....	17
2.2 Accessing Live View	18
2.2.1 The Live View Window	19
Chapter 3 PTZ Control Panel	23
3.1 Assessing the PTZ Control Panel.....	23
3.1.1 Setting Presets	24
3.1.2 Setting Patrol	26
3.2 Setting Home Position	31

Chapter 4 Administrator Mode32

4.1	Common	35
4.1.1	Navigation / Basic Info.....	35
4.1.2	Local Settings.....	36
4.2	Network	38
4.2.1	TCP/IP / Network.....	38
4.2.2	DNS.....	40
4.2.3	Port.....	40
4.2.4	Port Mapping	41
4.2.5	DDNS	42
4.2.6	E-mail	43
4.2.7	SNMP	45
4.2.8	802.1x.....	46
4.2.9	QoS	47
4.3	Video & Audio.....	48
4.3.1	Video	48
4.3.2	Audio	50
4.3.3	Snapshot	51
4.3.4	ROI.....	52
4.3.5	Media Stream	53
4.4	PTZ.....	55
4.4.1	Home Position	55
4.4.2	PTZ Limit	55
4.4.2	Remote Control.....	56
4.4.3	Patrol	57
4.5	Image	58
4.5.1	Image	58
4.5.2	OSD.....	65
4.5.3	Privacy Mask.....	67
4.6	Intelligent	68
4.6.1	Smart Settings	68
4.6.2	Cross Line	69
4.6.3	Intrusion.....	71
4.6.4	Object Moving.....	72
4.6.5	Object Left	73
4.6.6	Face Detection.....	74
4.6.7	People Counting	75
4.6.8	Auto Tracking	76

4.6.9	Advanced Settings	77
4.7	Events.....	78
4.7.1	Motion Detection.....	78
4.7.2	Tampering Alarm	80
4.7.3	Audio Detection	81
4.7.4	Alarm Input	82
4.7.5	Alarm Output	83
4.7.6	Capture.....	84
4.7.7	Temperature Alarm.....	84
4.8	Storage.....	85
4.8.1	Storage.....	85
4.8.2	Recording Download	87
4.8.3	FTP.....	88
4.8.4	Backing Up Storage.....	90
4.9	Security.....	91
4.9.1	User.....	91
4.9.2	Network Security.....	91
4.10	System.....	93
4.10.1	Time	93
4.10.2	DST	94
4.10.3	Maintenance	95
4.10.4	Security.....	97
4.10.5	Ports and Device	99

Chapter 5 Recording and Playback100

5.1	Recording	100
5.2	Playback from the Memory Card.....	101

Chapter 6 Advanced Applications103

6.1	Upgrading System Firmware.....	103
6.1.1	Using the Web Interface	104
6.1.2	Using the GV-IP Device Utility	105
6.2	Restoring to Factory Default Settings.....	106
6.2.1	Using the Web Interface	106
6.2.2	Directly on the Camera	107

Chapter 7 VMS / DVR / NVR Configurations.....108

- 7.1 Setting up IP Cameras on GV-DVR / NVR.....109
 - 7.1.1 Customizing the Basic Settings on GV-DVR / NVR.....111
- 7.2 Setting Up IP Cameras on GV-VMS112

Appendix114

- A RTSP Multicast Protocol Support114

Naming Definition

GV-DVR / NVR	GeoVision Analog and Digital Video Recording Software. The GV-DVR also refers to GV-Multicam System or GV-Hybrid DVR .
GV-VMS	GeoVision Video Management System for IP cameras.

Note for Connecting to GV-VMS / DVR / NVR

The GV-IP Speed Dome is designed to work with and record on GV-VMS / DVR / NVR, a video management system.

Once the camera is connected to the GV-VMS / DVR / NVR, the resolution set on the GV-VMS / DVR / NVR will override the resolution set on the camera's Web interface. You can only change the resolution settings through the Web interface when the connection to the GV-VMS / DVR / NVR is interrupted.

Note for Recording

By default, the images are recorded to the memory card inserted in the GV-IP Speed Dome. Mind the following when using a memory card for recording:

- Recorded data on the memory card can be damaged or lost if the data are accessed while the camera is under physical shock, power interruption, memory card detachment or when the memory card reaches the end of its lifespan. No guarantee is provided for such causes.
- The stored data can be lost if the memory card is not accessed for a long period of time. Back up your data periodically if you seldom access the memory card.
- Memory cards are expendable and their durability varies according to the conditions of the installed site and how they are used. Back up your data regularly and replace the memory card annually.
- To avoid power outage, it is highly recommended to apply a battery backup (UPS).
- For better performance, it is highly recommended to use Micro SD card or SD card of MLC NAND flash, Class 10.
- Replace the memory card when its read/write speed is lower than 6 MB/s or when the memory card is frequently undetected by the camera.

Note for Installing Camera Outdoor

When installing the camera outdoor, be sure that:

1. The camera is set up above the junction box to prevent water from entering the camera along the cables.

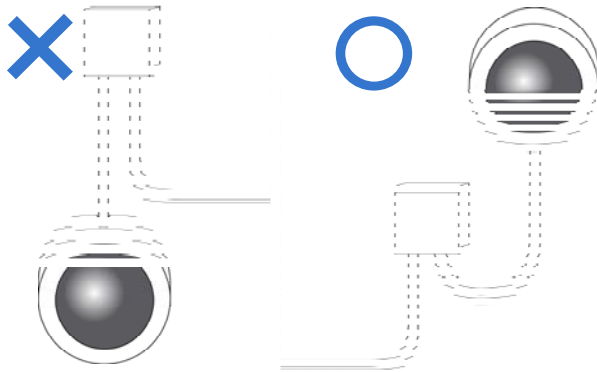

2. Any power, audio and I/O cables are waterproofed using waterproof silicon rubber or the like.

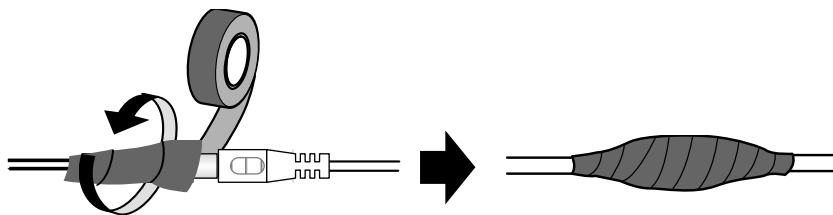

3. The screws are tightened and the cover is in place after opening the camera cover.

Note for Face Detection

To use the camera's built-in face detection feature (see 4.6.6 *Face Detection*), not supported by GV-SD2322-IR, it is recommended to install the camera according to the criteria listed below:

Surveillance Condition

- The camera shall be installed at a site with uniform, sufficient lighting, where the face(s) to be detected are fully illuminated.

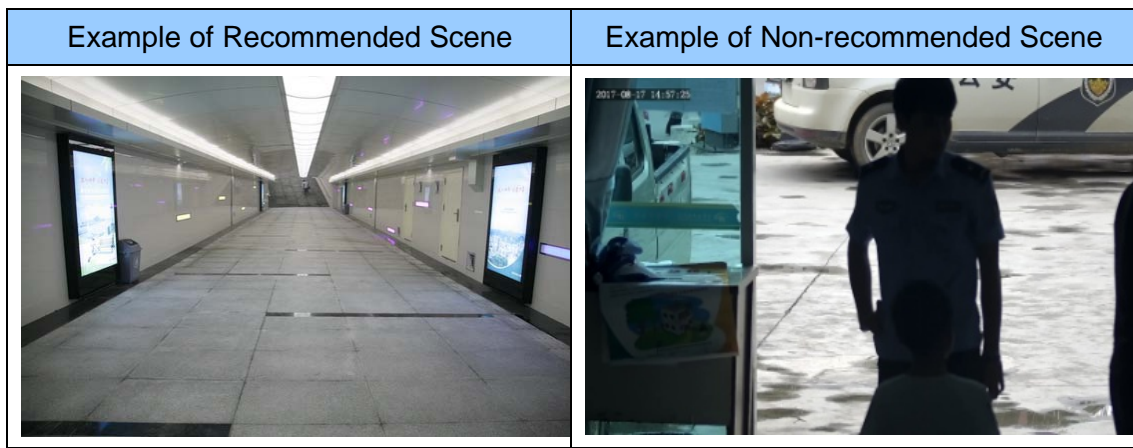

Camera Position

- The camera shall be mounted at a recommended height of 2.5 ~ 3 m (8.2 ~ 9.84).
- The camera shall be mounted with a recommended depression angle of around 10°.
- The camera shall be positioned so that the face(s) to be detected are directly aligned with the lens of the camera, with a horizontal deviation of no greater than 30°, a vertical deviation of no greater than 15° and a face size of at least 120 pixels.

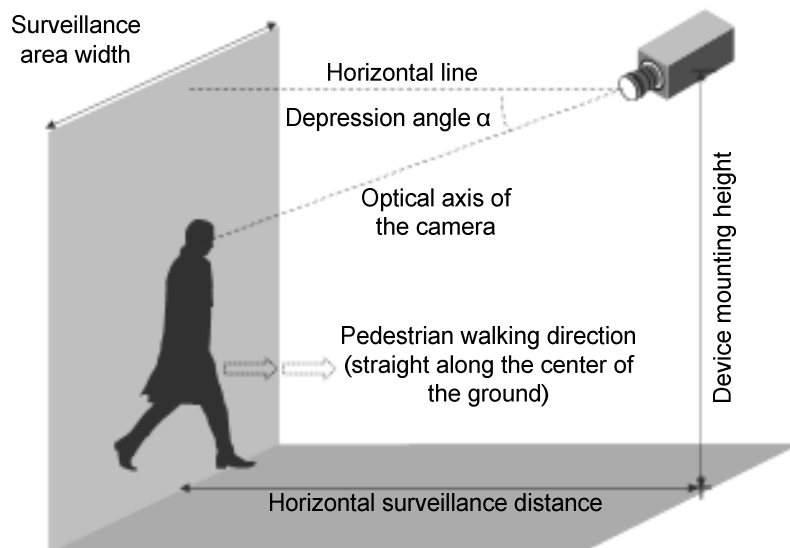

Note for People Counting

To use the camera's built-in people counting feature (see 4.6.7 *People Counting*), not supported by GV-SD2322-IR, it is recommended to install the camera according to the criteria listed below:

Surveillance Condition

- The camera shall be installed at a site with uniform, sufficient lighting, where the person(s) to be counted are fully illuminated.
- The camera shall be installed at an entrance or exit with an ideal width of 1 ~ 4 m (3.28 ~ 13.12), where the persons(s) to be counted move toward the lens of the camera in single file.

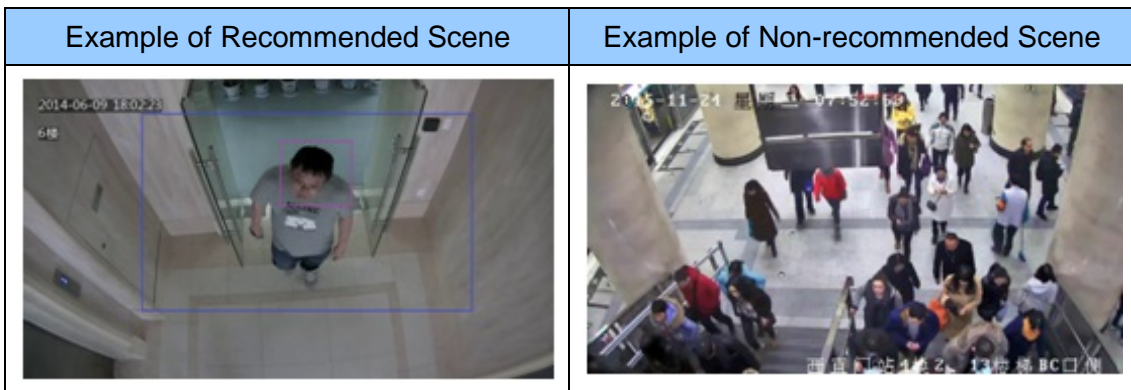

Camera Position

- The camera shall be mounted at a recommended height of 3 ~ 5 m (9.84 ~ 16.4 ft).
- The camera shall be mounted with a recommended depression angle of 70 ~ 80°.
- The camera shall be positioned so that the person(s) to be counted face toward the lens of the camera and are displayed on the image with a shoulder size of between 120 ~ 160 pixels.

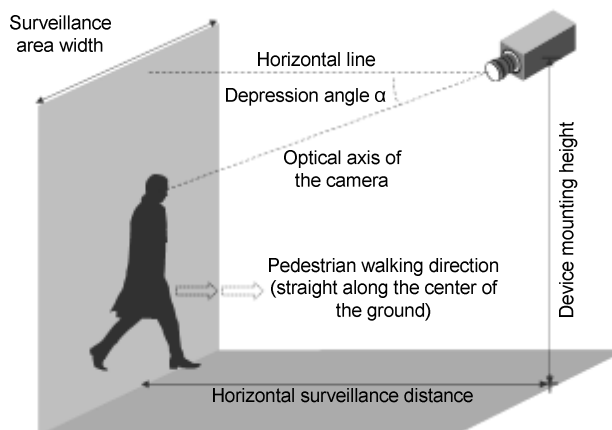

Chapter 1 Introduction

The GV-IP IR Speed Dome is an outdoor network PTZ camera that offers 22x / 33x optical zoom and unlimited digital zoom, capable of showing smooth live view with great details. This camera can simultaneously deliver three video streams in resolutions up to 1920 x 1080 at 30 fps (GV-SD2322-IR), 1920 x 1080 at 60 fps (GV-SD2722-IR), or 2048 x 1536 at 30 fps and 1920 x 1080 at 60 fps (GV-SD3732-IR). In low-light environments, night vision is enhanced with its high-power LEDs, which allow up to 150 m (492 ft) or 200 m (656 ft, GV-SD2722-IR) effective IR distance.

Wide surveillance coverage is made possible with 360° endless panning and -15 ~ 90° tilting capacity. PTZ functions such as Preset, Auto Pan and Patrol can be programmed and activated by schedule. The GV-IP IR Speed Dome supports pan/tilt speeds ranging from a fast patrol of 240° per second to a slow ramble of 0.1° per second with 0.1° pan accuracy for fast and accurate tracking ability.

For GV-SD2722-IR / 3732-IR, with the built-in WDR Pro, it can process scenes with contrasting intensity of lights and produce clear image. The camera supports H.265 video codec to achieve better compression ratio while maintaining high quality pictures at reduced network bandwidths.

1.1 Key Features

- 1/2.8" progressive scan low lux CMOS sensor
1/1.9" progressive scan low lux CMOS sensor (for GV-SD2722-IR only)
- Min. illumination at 0.01 lux (B/W) and 0.03 lux (color) (for GV-SD2322-IR)
Min. illumination at 0.03 lux (B/W) and 0.05 lux (color) (for GV-SD3732-IR)
Min. illumination at 0.001 lux (color) (for GV-SD2722-IR)
- Triple streams from H.264 and MJPEG (for GV-SD2322-IR only)
Triple streams from H.265, H.264 and MJPEG
- Up to 30 fps at 1920 x 1080 (for GV-SD2322-IR)
Up to 60 fps at 1920 x 1080 (for GV-SD2722-IR)
Up to 30 fps at 2048 x 1536, 60 fps at 1920 x 1080 (for GV-SD3732-IR)
- 22x optical zoom and unlimited digital zoom
33x optical zoom and unlimited digital zoom (for GV-SD3732-IR only)
- Intelligent IR
- IR distance up to 150 m (492 ft)
IR distance up to 200 m (656 ft) (for GV-SD2722-IR only)
- Day and night function (with removable IR-cut filter)
- Two sensor inputs and one alarm output
- Wide Dynamic Range (WDR) (for GV-SD2322-IR only)
Wide Dynamic Range Pro (WDR Pro)
- Vandal resistance (IK10 for metal casing)
- Ingress protection (IP66)
- Wide temperature tolerance (-40°C ~ 70°C / -40°F ~ 158°F)
- Support for TV-out
- Two-way audio
- Built-in micro SD card slot (SDHC/SDXC, Class 10) for local storage
- DC 24V / AC 24V
- Pan 360° endlessly
- Tilt from -15° to 90°
- Pan and tilt speed at up to 300° /s and 240° /s respectively

- PTZ movement (Preset, Auto Pan and Patrol)
- PTZ patrol by schedule
- Smart settings (Cross line, Intrusion, Auto tracking) (for GV-SD2722-IR / SD3732-IR only)
- Intelligent Mark (for GV-SD2722-IR / SD3732-IR only)
- Auto focus
- 3D noise reduction
- Motion detection
- Privacy mask
- ONVIF (Profile S) conformant (for GV-SD2322-IR only)
- ONVIF (Profile G, S, T) conformant

1.2 Packing List

- IR IP Speed Dome



- 24V AC Power Adapter



- M4 Hex Key



- Waterproof Rubber Set



- Waterproof Guidelines
- Download Guide
- Warranty Card







1.3 System Requirements

CPU	Intel Core i5-4670, 3.40 GHz
Memory	DDR3 8 GB RAM
On Board Graphics	Intel HD Graphics 4600 (Versions of driver from year 2014 or later required)
Web Browsers	<ul style="list-style-type: none">● Internet Explorer 11.0 or above● Google Chrome● Mozilla Firefox● Safari
Note: Some functions are not available on non-IE browsers.	

1.4 Optional Accessories

Optional accessories can expand the capabilities and versatility of your GV-IP Speed Dome. Contact your dealer for more information.

Model Number	Name	Details
GV-Mount104	Straight Tube Kit 	Dimensions: 219 x 125 x 332 mm (8.6" x 4.9" x 13.1") Weight: 1.8 kg (3.97 lb)
GV-Mount105	Straight Tube and Junction Box Kit 	Dimensions: 256 x 256 x 297 mm (10.1" x 10.1" x 11.7") Weight: 6.2 kg (13.67 lb)
GV-Mount208-3	Swan Neck Mount 	Dimensions: 1043 x 519 x 256 mm (41.06 x 20.43 x 10.08") Weight: 10.6 kg (23.37 lb)
GV-Mount210	Pendant Tube 	Dimensions: 200 x 140 x 249 mm (7.9" x 5.5" x 9.80") Weight: 1.1 kg (2.43 lb)

<p>GV-Mount300-1</p>	<p>Convex Corner Adapter Kit</p> 	<p>Dimensions: 238.6 x 395.2 x 210 mm (9.4" x 15.5" x 8.2") Weight: 4.27 kg (9.41 lb)</p>
<p>GV-Mount310-1</p>	<p>Concave Corner Adapter Kit</p> 	<p>Dimensions: 111.2 x 369.9 x 210 mm (4.37" x 14.5" x 8.2") Weight: 2.96 kg (6.53 lb)</p>
<p>GV-Mount400-1</p>	<p>Pole Mount Bracket Kit (Ø 4" ~ 6")</p> 	<p>Dimensions: Bracket: 68.4 x 240 x 163 mm (2.69" x 9.44" x 6.41") Weight: 1.70 kg (3.75 lb) Steel Strap Diameter: Ø 4" ~ 6"</p>
<p>GV-Mount410-1</p>	<p>Pole Mount Bracket Kit (Ø 6" ~ 7.5")</p> 	<p>Dimensions: Bracket: 68.4 x 240 x 163 mm (2.69" x 9.44" x 6.41") Weight: 1.70 kg (3.75 lb) Steel Strap Diameter: Ø 6" ~ 7.5"</p>
<p>GV-Mount501</p>	<p>Convex Corner Box Mount</p> 	<p>Dimensions: 136 x 256 x 256 mm (5.4 x 10.1 x 10.1") Weight: 4.8 kg (10.6 lb)</p>
<p>GV-Mount702</p>	<p>Extension Tube</p> 	<p>Four options are available. Dimensions: Ø 5.4 x 10 or 20 or 30 or 50 cm (Ø 2.1" x 3.9" or 7.9" or 11.8" or 19.7") Weight: 180 g or 390 g or 550 g or 800 g (0.4 lb or 0.86 lb or 1.21 lb or 1.76 lb)</p>

1.5 Physical Description



Figure 1-1

No.	Name	Function
1.	Default Button	Resets all configurations to default factory settings. See <i>6.2 Restoring to Factory Default Settings</i> .
2.	Micro SD Card Slot	Inserts a micro SD card (SDHC/SDXC, Class 10) to store recording data.

1.6 Accessory Installation (Wall Pendant Mount)

You can separately purchase optional mounting accessories to mount your GV-IP Speed Dome on a wall, ceiling or pole. Make sure the wall is strong enough to support the camera and the mount.



Figure 1-2

Required Items

- GV-Mount210 (purchased required)
- Wall screws x 4 (user-prepared)

Note: [GV-SD2722-IR / SD3732-IR](#) supports a series of Intelligent functions, which work best when the installation abides by specific requirements. See [4.6.1 Recommended Scenario](#) for details.

1. Unscrew the back cover of the camera.



Figure 1-3

2. Insert the micro SD card into the slot, and secure the back cover of the camera.



Figure 1-4

Note: Be sure to format the memory card on the camera's Web interface. See [4.7.1 Storage](#) for details.

3. Place the pendant tube on the wall, and mark the position of the screw holes.



Figure 1-5

4. Drill holes on the wall, and secure the pendant tube to the wall with 4 self-prepared screws.
5. Attach the safety lock of the camera to the pendant tube.



Figure 1-6

6. Thread the data cable through the pendant tube.



Figure 1-7

7. Attach the camera to the pendant tube, rotate the camera until it is locked into position, and secure the indicated screws.



Figure 1-8

8. Insert the pendant mount screws and tighten with the supplied M4 hex key.

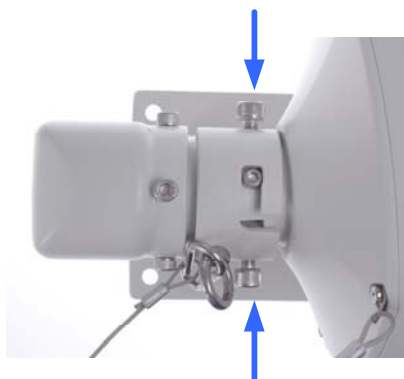

Figure 1-9

9. Thread the Ethernet cable through the waterproof rubber set as shown below.



Figure 1-10

Note: The size of RJ-45 connector must be within 14 mm to go through the waterproof rubber set.

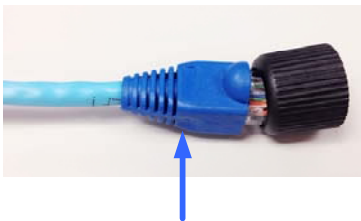

Unfit size of RJ45 Connector

1.7 Connecting the Camera

The camera comes with a data cable that allows you to connect the camera to the power adapter, microphone, speaker, and I/O devices.

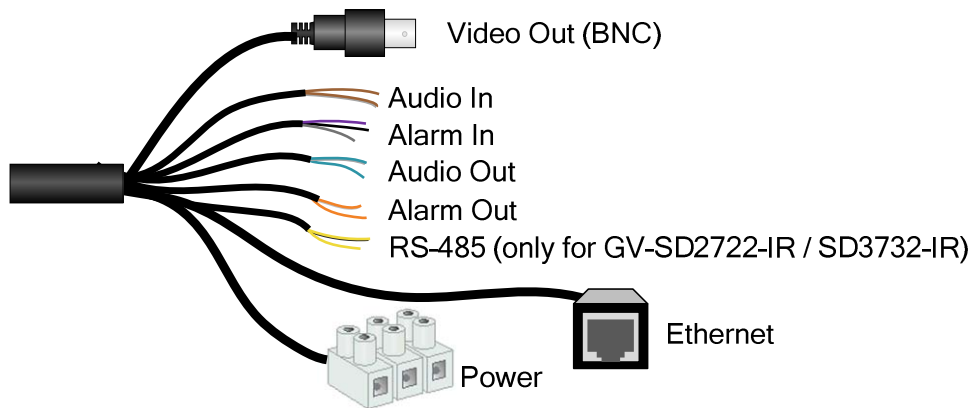

Figure 1-11

1. Connect the supplied power adapter to the 3-pin terminal block. Either of the red or black cables can be used for anode (+) and the cathode (-).

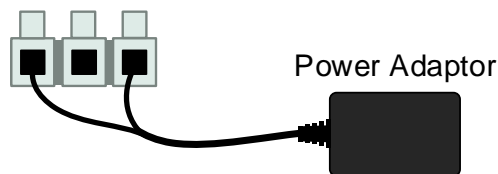

Figure 1-12

2. Connect a standard network cable to the Ethernet cable of the camera.
3. Optionally connect the TV-out (BNC) cable to a monitor. The TV-out function can be used during installation to adjust the camera image.
4. Optionally connect I/O devices, speaker and microphone to the camera. You can connect up to 2 alarm inputs and 1 output device. See *Wire Definition* section below.

Each time the camera is powered on, it will perform a self-test to check the Pan/Tilt/Zoom (PTZ) function. After the self-test, you can operate the camera.

Note: If you are using your own power adapter, you may need to ground the camera using the yellow cable (GND) on the 3-pin terminal block.

Wire Definition

No.	Wire	Definition
1	Brown	Audio in
2	Brown / White	GND
3	Green	Audio out
4	Green / White	GND
5	Gray	Alarm IN 1
6	Purple	Alarm IN 2
7	Black	GND
8	Orange	Alarm In -
9	Orange / White	Alarm Out +
10	Yellow	RS-485 – (only for GV-SD2722-IR / SD3732-IR)
11	Yellow / Black	RS-485 + (only for GV-SD2722-IR / SD3732-IR)

Power cable

The power loss in watts on the cable for different lengths and different core diameters is listed below.

Distance (Unit: m)	Core Diameter (Unit: mm)			
	0.80	1.00	1.25	2.00
30	28	45	72	183
40	21	34	54	137
50	17	27	43	110
60	-	22	36	91
70	-	19	31	78
80	-	-	27	68
90	-	-	24	61
100	-	-	21	55

Note: Data listed above is applicable to copper cables that use 24V AC / 24V DC power supply.

Chapter 2 Accessing the Camera

Once installed, the IP Speed Dome is accessible on a network. Follow these steps to configure the network settings and access your surveillance images.

2.1 Installing on a Network

These instructions describe the basic connections to install the camera on the network.

1. Using a standard network cable, connect the camera to your network.
2. Connect to power using the supplied power adapter.
3. You can now access the Web interface of the camera.
 - If the camera is installed in a LAN with DHCP server, use GV-IP Device Utility to look up the camera's dynamic IP address. See *2.1.1 Checking the Dynamic IP Address*.
 - If the camera is installed in a LAN without DHCP server, the default IP address **192.168.0.10** is applied. To assign a different static IP address, see *2.1.2 Assigning an IP Address*.

Note: You must set your browser to allow ActiveX Controls and perform a one-time installation of the ActiveX component onto your computer at your first login.

2.1.1 Checking the Dynamic IP Address

1. Download and install the **GV-IP Device Utility** program from the company [website](#).

Note:

1. The PC installed with GV-IP Device Utility must be under the same LAN with the camera you wish to configure.
2. Multilingual Web interface is only supported by **GV-SD2722-IR / SD3732-IR**.
3. By default, the Administrator's username is **admin** and cannot be modified.

2. On the GV-IP Utility window, click the  button to search for the IP devices connected in the same LAN. Click the **Name** or **Mac Address** column to sort.
3. Find the camera with its Mac Address, click on its IP address.

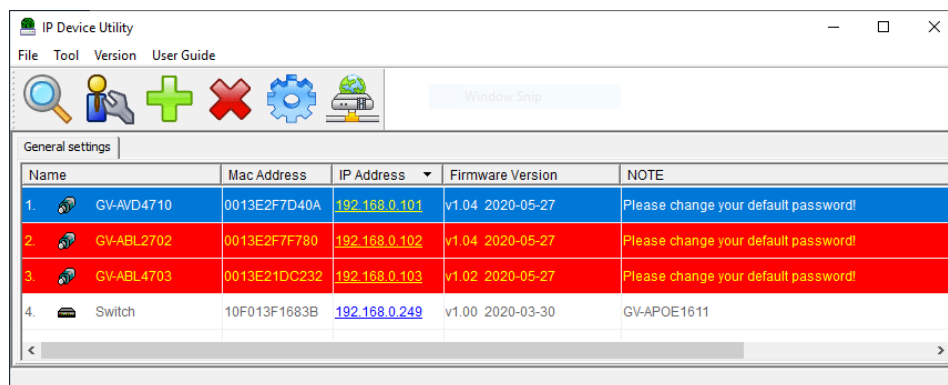

Figure 2-1

4. For the first-time users, you will be requested to set up a password.
5. Type a new password and click **OK**.
6. Type your username and password on the login page and click **Login**.

2.1.2 Assigning an IP Address

To assign a new static IP address, log in the Web interface to access the network setting page.

Note: If your router does not support DHCP, the default IP address will be **192.168.0.10**. In this case, it is highly recommended that you modify the IP address to avoid IP address conflict with other GV-IP devices on the same LAN.

1. Open your web browser, and type the default IP address **192.168.0.10**.
2. Type your username and password. Click **Login**.
3. Click **Setup**, select **Common** in the left menu and select **Network**.

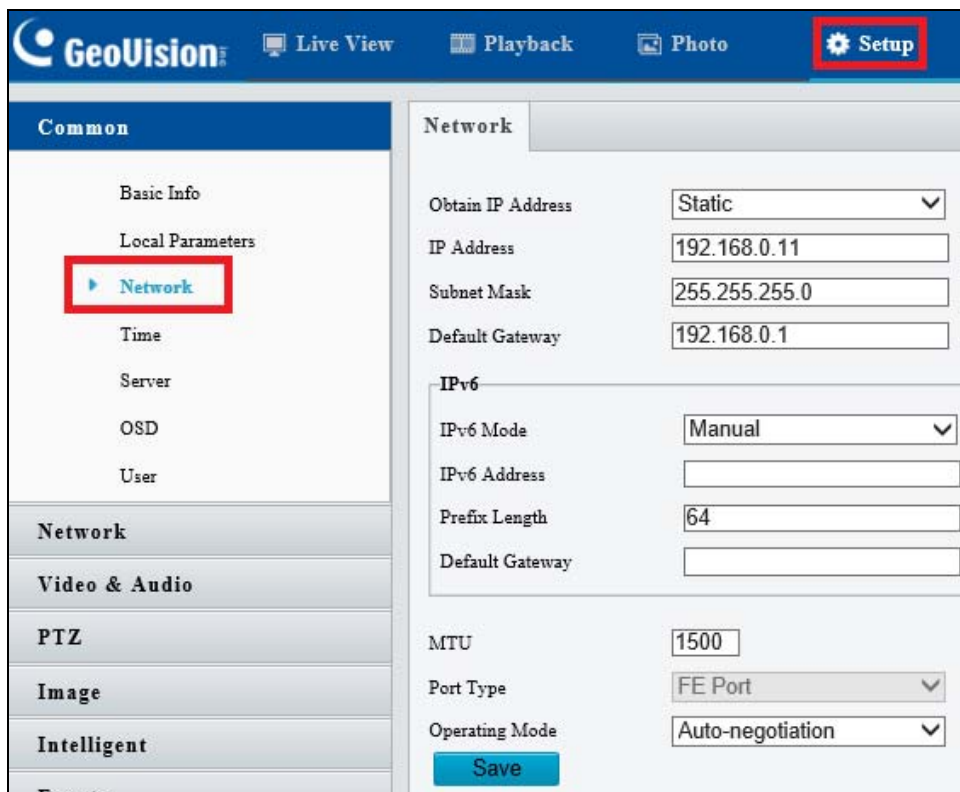

Figure 2-2

4. Select **Static** from the Obtain IP Address drop-down list.
5. Enter the IP address, subnet mask, and default gateway address. Make sure that the IP address of the camera is unique in the network.
6. Click **Save**.

2.2 Accessing Live View

After logging in to the speed dome, you will see the Home page as shown below:



Figure 2-3

2.2.1 The Live View Window

For GV-SD2322-IR

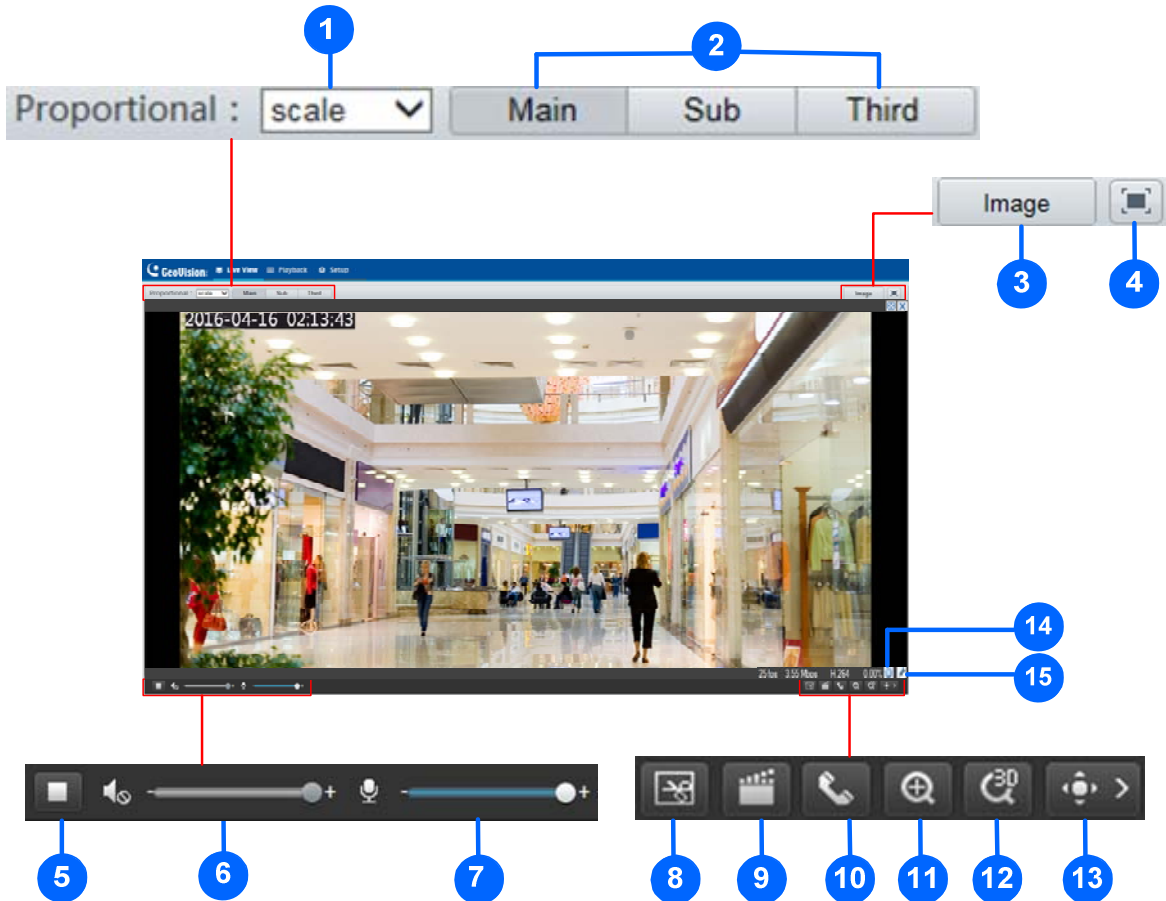













Figure 2-4

No.	Name	Function
1	Proportional	Set the display ratio of the image. <ul style="list-style-type: none"> • Scale: display images by 16:9. • Stretch: display images by window size. • Original: display images in its original size.
2	Live Stream	Select a live video stream: main stream, sub stream or third stream.
3	Image	Open the image setting page. – See 4.5.1 Image.
4	Full Screen Mode	Display in full screen mode.
5	Play/Stop	Play or stop live video.
6	Volume	Adjust the audio output volume on the PC.

7	Microphone	Adjust the microphone volume on the PC during audio communication between the PC and the camera.
8	Snapshot	Take a snapshot of the current image displayed on the PC.
9	Local Recording	Start  or stop  local recording.
10	Audio Communication	Start  or stop  audio communication between the PC and the camera.
11	Digital Zoom	Start  or stop  digital zoom. -- See 2.2.1.1 <i>Digital Zoom</i> .
12	3D Positioning	Start  or stop  3D positioning (optical zoom). -- See 2.2.1.2 <i>3D Positioning</i> .
13	PTZ control panel	Show  or hide  the PTZ control panel. -- See 3. <i>PTZ Control Panel</i> .
14		Reset the packet loss rate to zero.
15		Display packet loss rate and bit rate information in the bottom.

Note:

1. The paths for saving snapshots and local recordings are set in System Configuration.
2. The buttons (No. 14 and No. 15) will appear on the floating toolbar after you move the mouse cursor on a live view window.
3. Click the button (No. 15) to display the bottom information. Click this button again, the bottom information is displayed if the mouse cursor is moved on a live view window or on the bottom information, and it hides automatically if the mouse cursor remains on a live view window for 3 seconds or leaves the window.

For GV-SD2722-IR / SD3732-IR

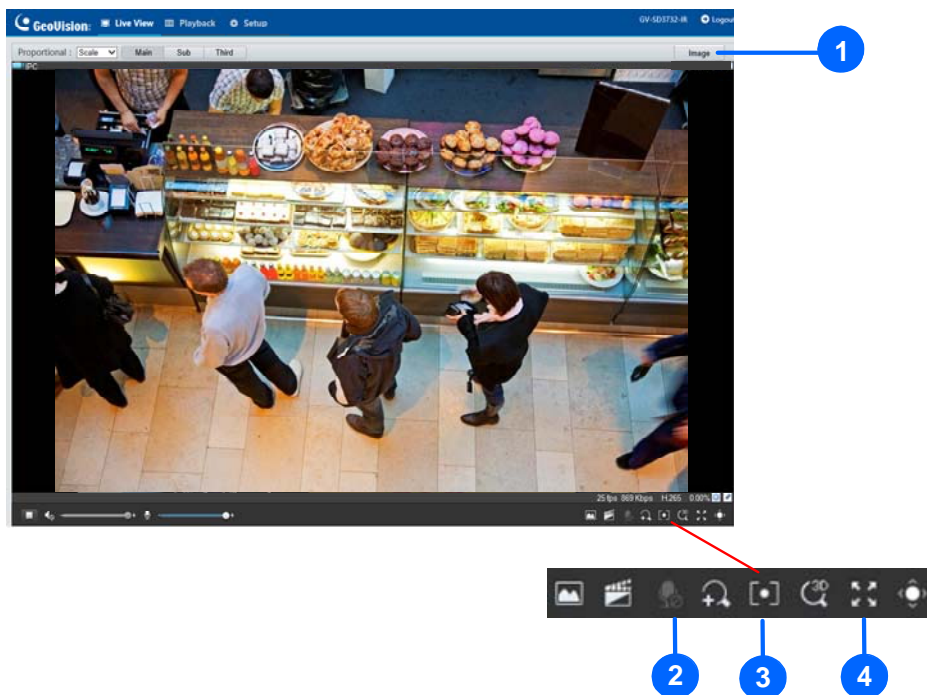









Figure 2-5

No.	Name	Function
1	Image	Open the image setting page. -- See 4.5.1 Image.
2	Two-way Audio	Start  or stop  two-way audio.
3	Area Focus	Start  or stop  area focus. By activating this function, you can set the camera focus based on a defined area of the live view. To activate Area Focus, follow the steps below: Step 1: Click  on the toolbar. Step 2: Click and drag on the live view to specify an area. The focus of the live view changes to the specified area.
4	Full Screen Mode	Display in full screen mode.



For other functions in the live view window, refer to Figure 2-4.

2.2.1.1 Digital Zoom

To use the digital zoom function, follow these steps:

1. Click  (No. 11, Figure 2-4) on the toolbar.
2. Click and drag on the live view from top to down to specify an area.
3. To restore the original image size, click in the enlarged area, or drag from the bottom up.
4. To exit, click  (No. 11, Figure 2-4) on the toolbar.

2.2.1.2 3D Positioning (Optical Zoom)

1. Click  (No. 12, Figure 2-4) on the toolbar.
2. Click and drag on the live view from top to down to specify an area.
3. To zoom out, drag from the bottom up.
4. To exit, click  (No. 12, Figure 2-4) on the toolbar.

Chapter 3 PTZ Control Panel

In this chapter, you will be guided through the various functions of PTZ Control Panel. The PTZ Control Panel is accessed from the live view interface of the camera.

3.1 Assessing the PTZ Control Panel

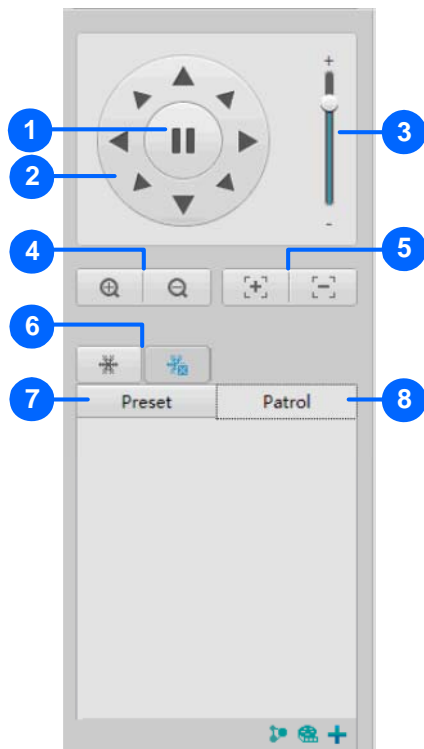

Figure 3-1

No.	Item	Function
1	Auto Pan	Start or stop auto panning of the camera.
2	PTZ Control Panel	Control the direction of the camera and release the control.
3	PTZ Speed	Adjust the moving speed of the PTZ camera.
4	Zoom	Adjust the camera's zoom (optical).
5	Focus	Adjust the camera's focus.
6	Snow	Turn on or off the snow control. When enabled, the camera will rotate to remove accumulated snow if detected by the camera.
7	Preset	Select a preset and the camera goes to the selected preset. -- See 3.1.1 Setting Presets.
8	Patrol	Select a patrol route. -- See 3.1.2 Setting Patrol.

3.1.1 Setting Presets

You can create and delete preset points by clicking Preset on the control panel of Live View.

Adding a Preset

1. Once **Preset** (No.7, Figure 3-1) is selected in the control panel, adjust the dome view to the desired direction, zoom and focus.

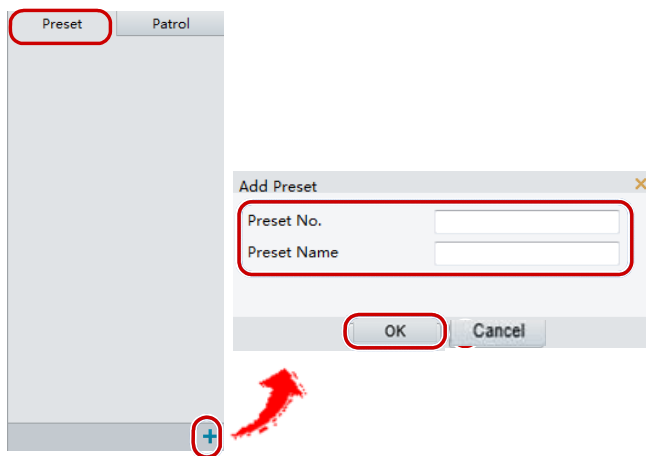



Figure 3-2

2. Click the **Add** button  to add it as a preset.
3. Enter a number and name for the preset and click **OK**.

Going to a Preset



On the control panel, click  for a preset. The PTZ camera goes to the selected preset.



Figure 3-3

Deleting a Preset

On the control panel, click  for a preset and confirm the delete.

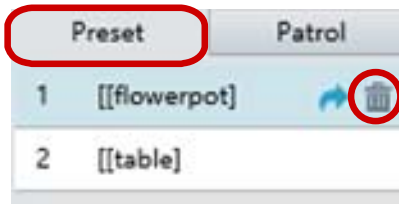

Figure 3-4

3.1.2 Setting Patrol

A patrol route is the track by which the camera follows when moving from a preset to the next. The length of time that the camera stays at each preset is configurable. Multiple patrol routes are allowed for the camera.

Patrol actions include going to a preset and staying at the preset for a certain amount of time before going to the next. You can set the rotation direction, zoom, rotation speed, patrol time, and stay time. You can also record a route and add it to the action list.

Note: To enable **Preset Snapshot**, see [4.4.2 Patrol](#).

To access the Patrol functions, click **Patrol** on the control panel of Live View.

Adding a Patrol Route

1. On the control panel, click the **Add** button  to add a patrol route.

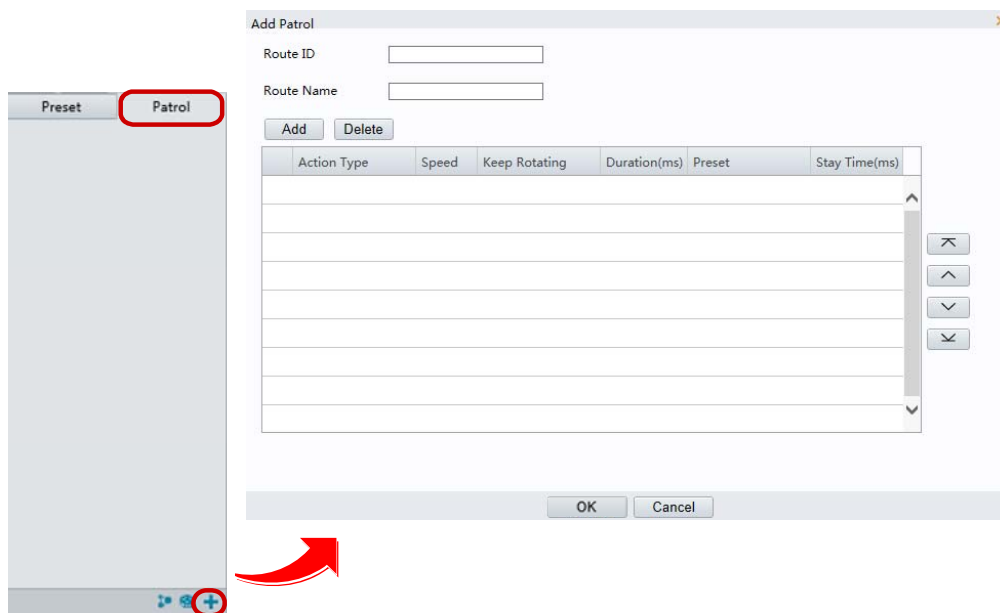

Figure 3-5

2. On the **Add Patrol** page, type the desired route ID and name.
3. Click **Add** to add a patrol action. Use the buttons to adjust the sequence of the actions and click **OK**.

Note:

1. It is recommended that the first action type is **Go to Preset**.
2. If **Keep Rotating** is selected, the camera will rotate at the set speed and zoom in the set direction or position for a certain amount of time.

Recording a Patrol Route

You can record the dome movements of the camera as a patrol route. The recorded movements are added to the action list.

1. On the control panel, click the **Record** button  to start recording the patrol route.

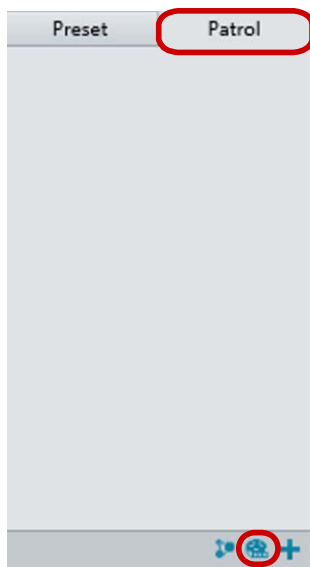





Figure 3-6

2. Click  to finish recording. The patrol route is saved as a mode route automatically.
3. Click  to start patrol or  to delete the mode route.

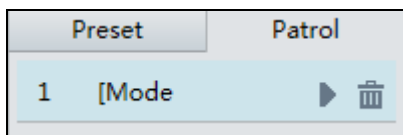



Figure 3-7

Starting a Patrol Route

After you have added a patrol route, you can start patrolling by clicking  on the control panel.

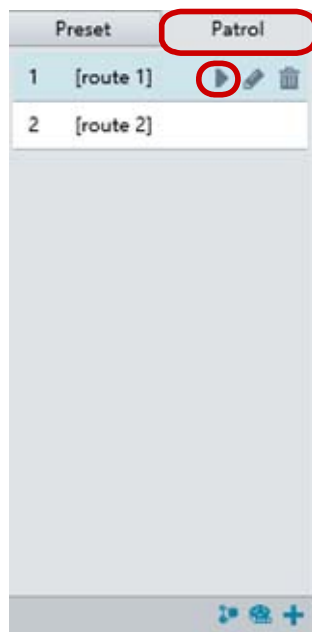



Figure 3-8

Editing a Patrol Route

On the control panel, click  to modify the ID, name and dome movement of an existing patrol route.

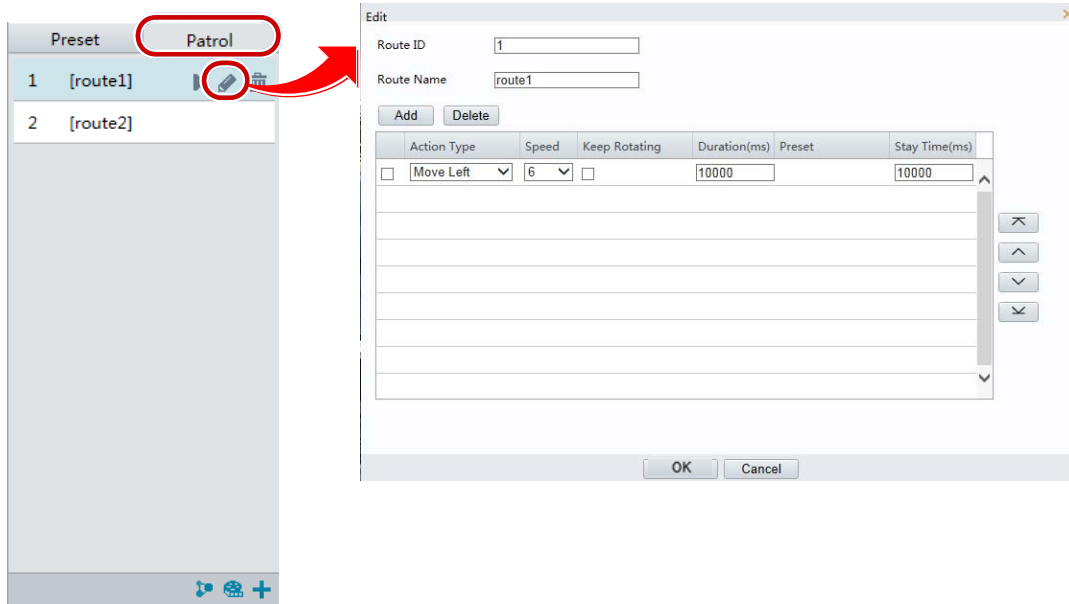



Figure 3-9

Delete a Patrol Route

On the control panel, click  for a patrol route and confirm the delete.

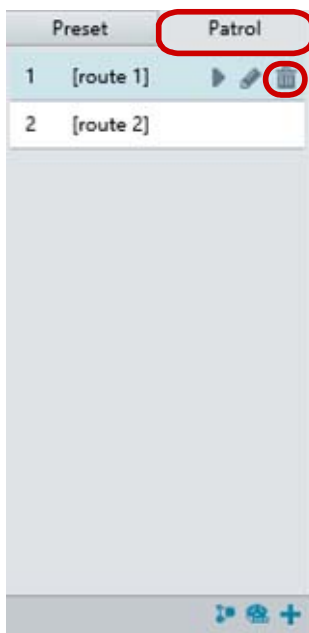



Figure 3-10

Making a Patrol Plan

You can set up the camera to perform different patrol routes at different time periods throughout the week by making a patrol plan.

1. On the control panel, click the **Patrol Plan** button  to set the correct patrol time and route.

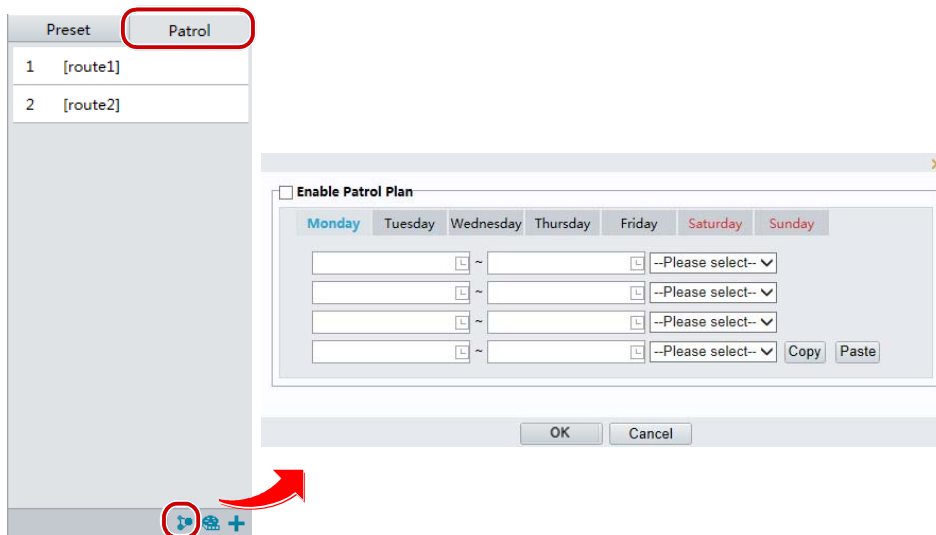

Figure 3-11

2. Select **Enable Patrol Plan**.
3. Click **OK**.

3.2 Setting Home Position

PTZ camera will return to home position if no operation is made within a specified period.

1. On the **Setup** page, select **PTZ** in the left menu and select **Home Position** to access the settings.

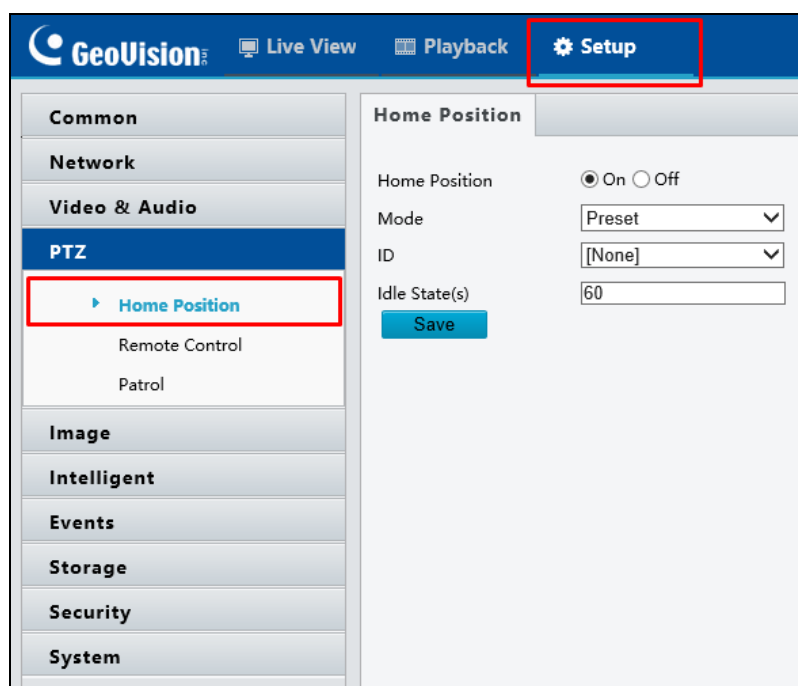

Figure 3-12

2. Select the desired preset as the home position and set the time.

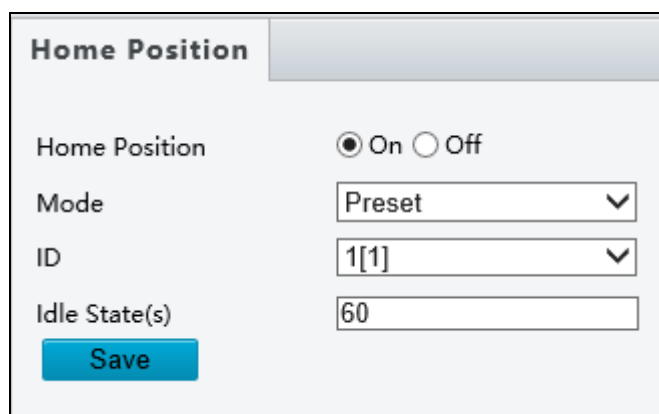

Figure 3-13

3. Click **Save**.

Chapter 4 Administrator Mode

The Administrator can access and configure GV-IP Speed Domes through the network. Click **Setup** at the top of the Web interface to access the following nine configuration tabs: **Common**, **Network**, **Video & Audio**, **PTZ**, **Image**, **Intelligent**, **Events**, **Storage**, **Security** and **System**. The configuration tabs may vary based on available models.

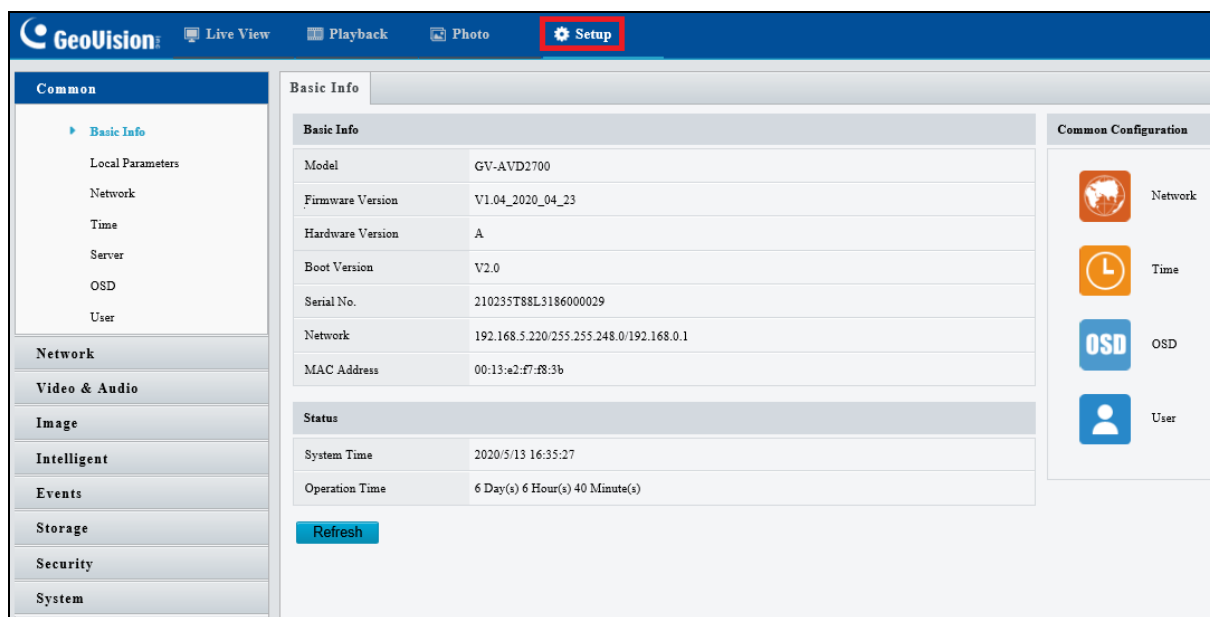

Figure 4-1

List of Options

See the table below for the settings available on the Web interface. Find the topic of interest by referring to the section number prefixed to each option. The configuration tabs and settings may vary with different models.

4.1 Common	<ul style="list-style-type: none"> 4.1.1 Navigation / Basic Info 4.1.2 Local Settings
4.2 Network	<ul style="list-style-type: none"> 4.2.1 TCP/IP / Network 4.2.2 DNS 4.2.3 Port 4.2.4 Port Mapping 4.2.5 DDNS 4.2.6 E-mail 4.2.7 SNMP 4.2.8 802.1x 4.2.9 QoS
4.3 Video & Audio	<ul style="list-style-type: none"> 4.3.1 Video 4.3.2 Audio 4.3.3 Snapshot 4.3.4 ROI 4.3.5 Media Stream
4.4 PTZ	<ul style="list-style-type: none"> 4.4.1 Home Position 4.4.2 PTZ Limit 4.4.2 Remote Control 4.4.3 Patrol
4.5 Image	<ul style="list-style-type: none"> 4.5.1 Image 4.5.2 OSD 4.5.3 Privacy Mask
4.6 Intelligent	<ul style="list-style-type: none"> 4.6.1 Smart Settings 4.6.2 Cross Line 4.6.3 Intrusion 4.6.4 Object Moving 4.6.5 Object Left 4.6.6 Face Detection 4.6.7 People Counting 4.6.8 Auto Tracking 4.6.9 Advanced Settings

4.7 Events	<ul style="list-style-type: none"> 4.7.1 Motion Detection 4.7.2 Tampering Alarm 4.7.3 Audio Detection 4.7.4 Alarm Input 4.7.5 Alarm Output 4.7.6 Capture 4.7.7 Temperature Alarm
4.8 Storage	<ul style="list-style-type: none"> 4.8.1 Storage 4.8.2 Recording Download 4.8.3 FTP 4.8.4 Backing Up Storage
4.9 Security	<ul style="list-style-type: none"> 4.9.1 User 4.9.2 Network Security
4.10 System	<ul style="list-style-type: none"> 4.10.1 Time 4.10.2 Maintenance 4.10.3 Security 4.10.4 Ports & Device

4.1 Common

Under the Common tab, the Administrator can find the general settings for the camera, as well as shortcuts to the following setting pages.

- **TCP/IP / Ethernet:** See 4.2.1 *TCP/IP / Network* for details.
- **Time:** See 4.10.1 *Time* for details.
- **OSD:** See 4.5.2 *OSD* for details
- **User:** See 4.10.3 *Security* for details

4.1.1 Navigation / Basic Info

You can view the current status of your camera. Click **Refresh** for the latest status information. Under Common Configuration on the right, you can click on the icons to quickly access the configuration pages.

The screenshot displays the camera's web interface. At the top, there are two tabs: 'Basic Info' (selected) and 'about'. The main content area is divided into two columns. The left column contains a table of basic information and a status section. The right column contains a 'Common Configuration' sidebar with four icons: Network (globe), Time (clock), OSD (blue box with 'OSD'), and User (person icon). At the bottom left, there is a blue 'Refresh' button.

Basic Info	
Model	GV-SD3732-IR
Firmware Version	V1.03_2020_05_27
Hardware Version	A
Boot Version	V3.7
Serial No.	210235T23Q3166000018
Network	192.168.5.171/255.255.248.0/192.168.0.1
MAC Address	00:13:a2:fa:10:52

Status	
System Time	2017/1/1 08:54:27
Operation Time	0 Day(s) 0 Hour(s) 53 Minute(s)

Common Configuration

-  Network
-  Time
-  OSD
-  User

Refresh

Figure 4-2

4.1.2 Local Settings

You can set local parameters for your PCs.

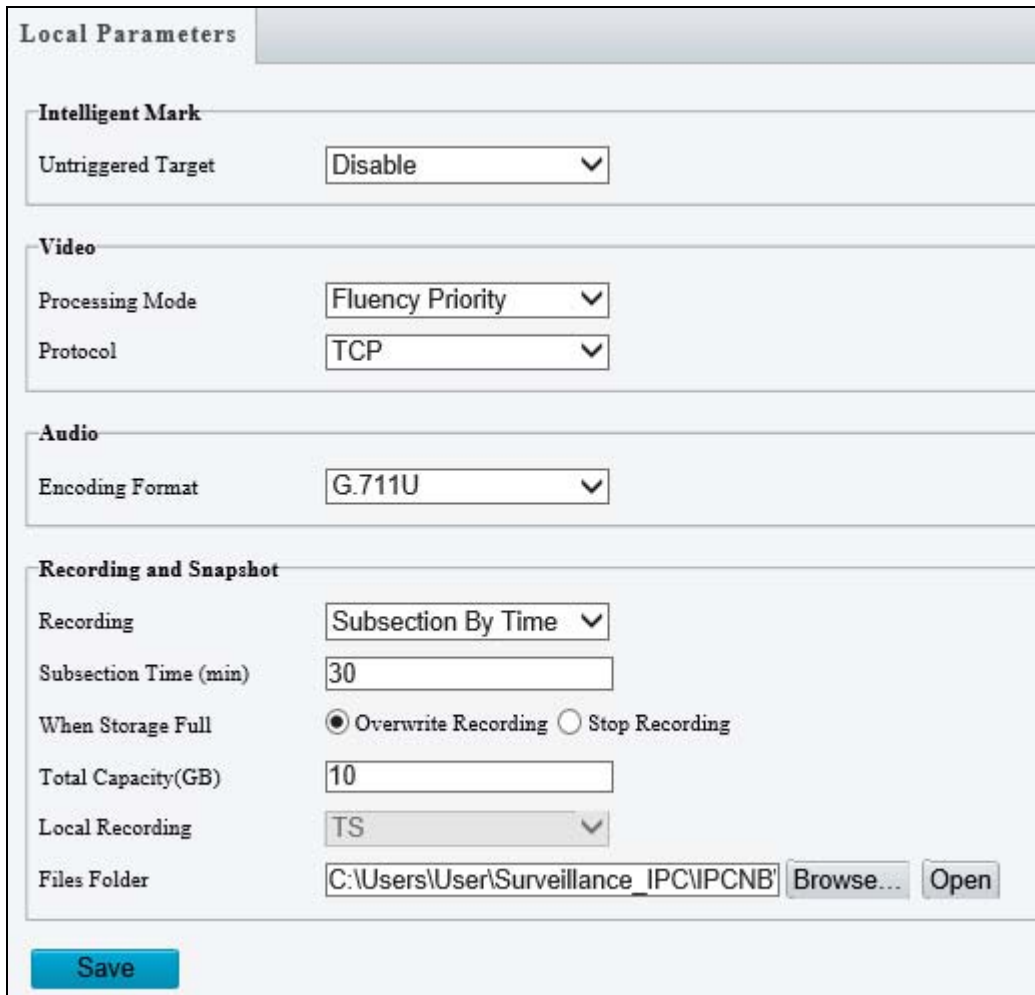

Figure 4-3

[Intelligent Mark]

- **Untriggered Target:** Displays the detection lines / areas defined by **Smart Settings** on Live View. You must set up Smart Settings first for this function to work, see 4.6 *Intelligent*. Note this function is not supported by GV-SD2322-IR.

[Video Param / Video]■ **Processing Mode**

- ⊙ **Real Time Prior / Real Time Priority:** Select this if the network is in good condition.
- ⊙ **Fluent Prior / Fluency Priority:** Select this if you want short time lag for live video.
- ⊙ **Ultra-Low Delay / Ultra-Low Latency:** Select this if you want the minimum time lag for live video.

- **Video Pixel Format:** Select the video format for images at your local computer. It is recommended to choose YUV420 if the graphic card of your PC supports it. This function is only applicable to **GV-SD2322-IR**.

- **Protocol:** Select the protocol used to transmit media streams to be decoded by the PC.

[Audio Param] The audio codec and sampling rate used are shown here.

[Recording and Snapshot]■ **Recording**

- ⊙ **Subsection By Time:** Set a maximum time length of each recording file. If you select 5 minutes, a 30-minute event will be chopped into six 5-minute event files.
- ⊙ **Subsection by Size:** Set a maximum size limit of each recording file.

■ **When Storage Full**

- ⊙ **Overwrite Recording:** When the assigned storage space on the computer is used up, the camera deletes the existing recording files to make room for the new recording file.
- ⊙ **Stop Recording:** When the assigned storage space on the computer is full, recording stops automatically.

- **Total Capacity:** Set a capacity limit to the assigned storage space on the computer.

- **Recording Folder / Files Folder:** Click **Browse** to set a folder to store the recorded videos at your local computer.

- **Snapshot Folder:** Click **Browse** to set a folder to store the captured snapshots at your local computer. To assign the snapshot-storing location for **GV-SD2722-IR / SD3732-IR**, go to **Storage** in the left menu and select **FTP**.

4.2 Network

The network section allows you to configure the network settings, modify ports, configure FTP server, and set up e-mail for notification.

4.2.1 Network

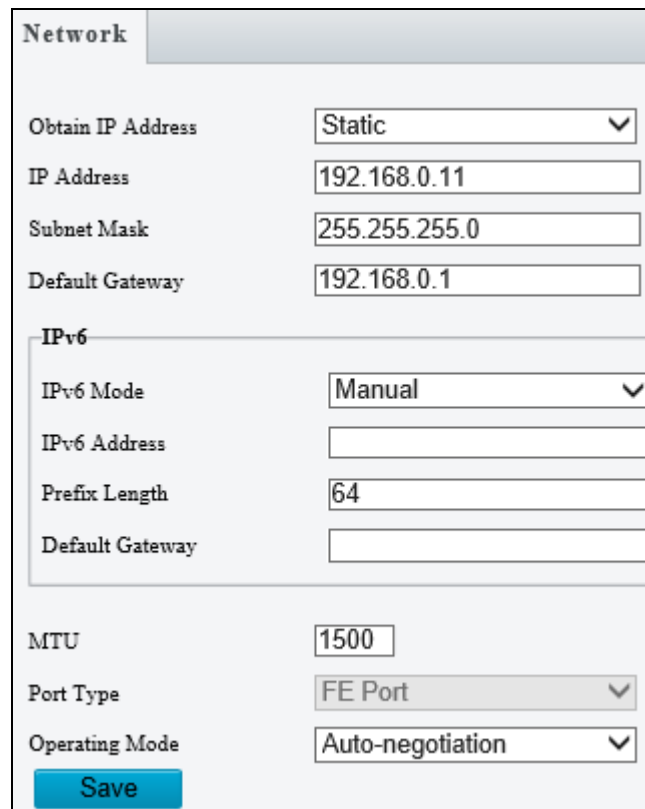

Network	
Obtain IP Address	Static
IP Address	192.168.0.11
Subnet Mask	255.255.255.0
Default Gateway	192.168.0.1
IPv6	
IPv6 Mode	Manual
IPv6 Address	
Prefix Length	64
Default Gateway	
MTU	1500
Port Type	FE Port
Operating Mode	Auto-negotiation
Save	

Figure 4-4

- **IP Obtain Mode / Obtain IP Address:** Select **Static IP**, **PPPoE** or **DHCP** according to your network environment.

- ⊙ **Static IP address:** Assign a static IP or fixed IP to the camera. Type the camera's IP address, Subnet Mask, Router/Gateway, Preferred DNS server and Alternate DNS server.

Parameters	Default
IP address	192.168.0.10
Subnet Mask	255.255.255.0
Router/Gateway	192.168.0.1
Preferred DNS server	8.8.8.8
Alternate DNS server	8.8.4.4

- ⊙ **PPPoE:** The network environment is xDSL connection. Type the Username and Password provided by ISP to establish the connection. If you use the xDSL connection with dynamic IP addresses, first use the DDNS function to obtain a domain name linking to the camera's changing IP address. Note this function is only applicable to **GV-SD2722-IR / SD3732-IR**.
- ⊙ **DHCP:** The network environment has a DHCP server which will automatically assign a dynamic IP address to the camera. You can look up the current IP address using GV-IP Device Utility.
- **IPv6:** Type the camera's **IPv6 Address** and **Default Gateway**. Optionally change the **Prefix Length** according to your network settings. Note this function is only applicable to **GV-SD2722-IR / SD3732-IR**.

Note: To enable IPv6, make sure your network environment and hardware specifications support IPv6.

- **Operating Mode:** Select a mode to control the bandwidth.

4.2.2 DNS

Type the camera's **Preferred DNS Server** and **Alternate DNS Server**. For **GV-SD2322-IR**, you can find the same setting in TCP / IP of the left menu.

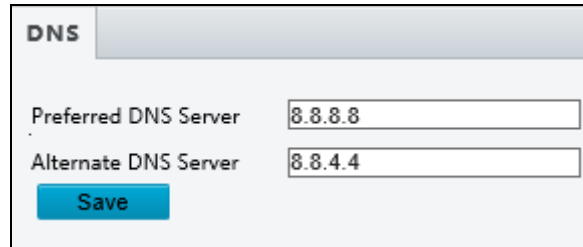

DNS	
Preferred DNS Server	<input type="text" value="8.8.8.8"/>
Alternate DNS Server	<input type="text" value="8.8.4.4"/>
<input type="button" value="Save"/>	

Figure 4-5

4.2.3 Port

You can modify the default **HTTP port**, **HTTPS port** and **RTSP port** if necessary.

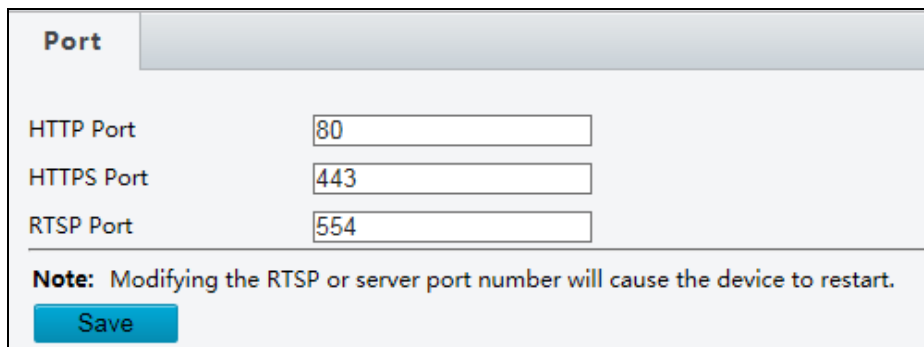

Port	
HTTP Port	<input type="text" value="80"/>
HTTPS Port	<input type="text" value="443"/>
RTSP Port	<input type="text" value="554"/>
Note: Modifying the RTSP or server port number will cause the device to restart.	
<input type="button" value="Save"/>	

Figure 4-6

4.2.4 Port Mapping

Note this function is only applicable to **GV-SD2722-IR / SD3732-IR**.

This function can automatically forward and open certain ports on your router, allowing connection to your camera from the Internet.

Port Mapping On Off

Mapping Type

Port Type	External Port	External IP Address	Status
HTTP Port	<input type="text" value="80"/>	0.0.0.0	Inactive
RTSP Port	<input type="text" value="554"/>	0.0.0.0	Inactive
Server Port	<input type="text" value="81"/>	0.0.0.0	Inactive

Figure 4-7

1. Enable **Port Mapping**, and select **Mapping Type**.
2. If you select **Automatic**, external ports will be automatically configured by the router.
3. If you select **Manual**, configure the external ports. External IP is applied to the camera automatically. If the configured port is occupied, the **Status** will show inactive.
4. Click **Save**.

Note: For this function, your router needs to support **port forwarding**.

4.2.5 DDNS

Note this function is only applicable to **GV-SD2722-IR / SD3732-IR**.

DDNS (Dynamic Domain Name System) provides a convenient way of accessing the camera when using a dynamic IP. DDNS assigns a domain name to the camera, so that the Administrator does not need to go through the trouble of checking if the IP address assigned by DHCP Server or ISP (in xDSL connection) has changed.

Before enabling the DDNS function, the Administrator should apply for a Host Name from the DDNS service provider's website. There are 2 providers listed in the camera: GeoVision GVDIP, GeoVision DDNS Server and DynDNS.org.

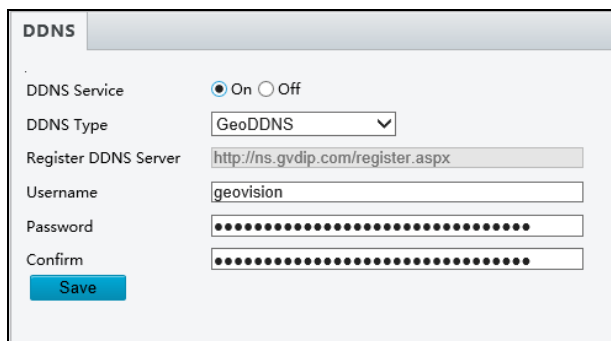

Figure 4-8

1. Click **On** to enable **DDNS Service**.
2. Select the DDNS service provider you have registered with. If you chose DynDNS, skip to *Step 5*.
3. Copy the website address <http://ns.gvdip.com/register.aspx> to a browser to access Geovision DDNS service.

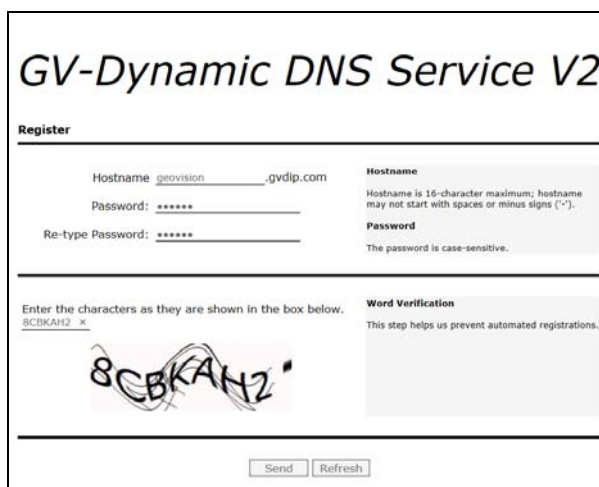

Figure 4-9

4. In the Geovision DDNS Server page, type a desired **Hostname** and **Password**. Re-type Password and type the verification letters shown in the image. Click **Send**.
5. In the Web interface of your camera, type **Username**. The username is the hostname registered in DDNS Server.
6. Type **Password**, and **Confirm Password**.
7. Click **Save**.

After the DDNS is successfully configured, a notification bar will be displayed as shown in *Figure 4-11*. Next time when you want to log in the camera, type the domain name like this: (hostname).gvdip.com, for example, geovision.gvdip.com.

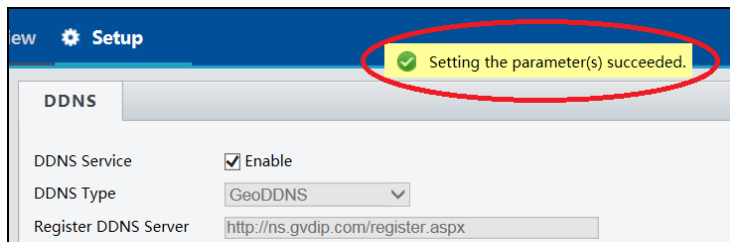

Figure 4-10

4.2.6 E-mail

After the configuration of E-mail, you will be able to send messages to the specified E-mail address when alarms are triggered.

A screenshot of the "E-mail" configuration page. The page is divided into two main sections: "Sender" and "Recipient". Under "Sender", there are fields for "Name", "Address", "SMTP Server", "SMTP Port" (set to 25), "TLS/SSL" (radio buttons for "On" and "Off", with "Off" selected), "Snapshot Interval(s)" (set to 2), "Attach Image" (checked), "Server Authentication" (radio buttons for "On" and "Off", with "On" selected), "Username" (set to "user@geovision.com"), and "Password" (masked with dots). Under "Recipient", there are three sets of fields for "Name" and "Address", each with a "Test" button. At the bottom left, there is a "Save" button.

Figure 4-11

[Sender]

1. Type the **Name** and **Address** of the sender.
2. Type the **SMTP Server**.
3. Type the **SMTP Port** number.
4. To send the e-mail through TLS / SSL encryption, enable **TLS / SSL**.
5. Enable **Attach Image** to include 3 instant snapshots as attachment in the e-mail according to the **Snapshot Interval (s)** specified.
6. If the SMTP Server needs authentication, enable **Server Authentication** and type a valid username and password to log in the SMTP server.

[Recipient] Type the name and e-mail address of the recipient.

For **GV-SD2722-IR / SD3732-IR**, click the button next to the address of a **Recipient to Test** for the validity of the e-mail address.

Note: To send snapshots to the specified E-mail address, make sure to enable **Snapshot in Video & Audio**. For more detailed instructions, refer to [4.3.3 Snapshot](#).

4.2.7 SNMP

Note this function is only applicable to **GV-SD2722-IR / SD3732-IR**.

Users can transfer the configurations of the device through SNMP protocol to communicate with and/or integrate it into a central server.

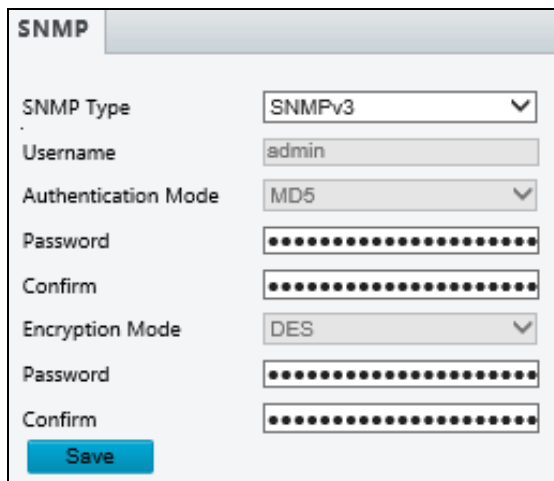

The image shows a web-based configuration form for SNMP. The form is titled "SNMP" and contains the following fields:

- SNMP Type:** A dropdown menu with "SNMPv3" selected.
- Username:** A text input field containing "admin".
- Authentication Mode:** A dropdown menu with "MD5" selected.
- Password:** A password input field with 12 dots.
- Confirm:** A password input field with 12 dots.
- Encryption Mode:** A dropdown menu with "DES" selected.
- Password:** A password input field with 12 dots.
- Confirm:** A password input field with 12 dots.

A blue "Save" button is located at the bottom left of the form.

Figure 4-12

- **SNMP Type:** Select the type of SNMP desired, between SNMPv3 and SNMPv2.
- **Authentication Mode:** Define a desired password for authentication between the device and the central server.
- **Encryption Mode:** Define a desired password for encryption that needs to be matched by the central server.

Click **Save** for the changes to take effect.

4.2.8 802.1x

Note this function is only applicable to **GV-SD2722-IR / SD3732-IR**.

IEEE 802.1x is an IEEE standard for port-based Network Access Control. It provides an authentication mechanism to devices connecting to a LAN or WLAN.

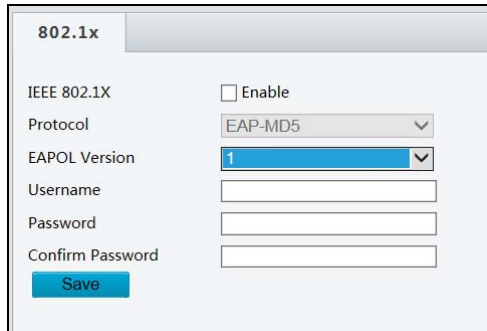

The screenshot shows a configuration window titled "802.1x". It contains the following fields and controls:

- IEEE 802.1X**: A checkbox labeled "Enable" which is currently unchecked.
- Protocol**: A dropdown menu with "EAP-MD5" selected.
- EAPOL Version**: A dropdown menu with "1" selected.
- Username**: An empty text input field.
- Password**: An empty text input field.
- Confirm Password**: An empty text input field.
- Save**: A blue button at the bottom left.

Figure 4-13

1. Enable **IEEE 802.1x**.
2. Type the **Username** and **Password**. Type the password again for confirmation.
3. Click **Save**.

Note: For this function, your network environment needs to support **802.1x**.

4.2.9 QoS

Note this function is only applicable to **GV-SD2722-IR / SD3732-IR**.

QoS is the prioritization of network traffic used to ensure resource reservation under abundant data flow.

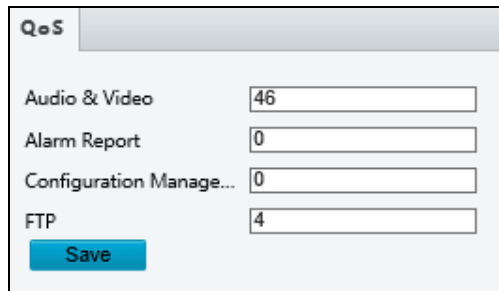

Category	Priority Value
Audio & Video	46
Alarm Report	0
Configuration Manager	0
FTP	4

Figure 4-14

- **Audio & Video:** Optionally modify the priority of value of Audio & Video. The higher the value, the higher the priority.
- **Alarm Report:** Optionally modify the priority of value for Alarm Report. The higher the value, the higher the priority.
- **Configuration Manager:** Optionally modify the priority for Configuration Manager. The higher the value, the higher the priority.
- **FTP:** Optionally modify the priority of value for FTP. The higher the value, the higher the priority.

Click **Save** to apply the QoS settings configured.

4.3 Video & Audio

This section allows you to configure the three video streams, as well as audio settings.

4.3.1 Video

You can set video parameters that your camera supports and view the current status of BNC output. You may also enable the sub-stream and third stream as needed.



The screenshot displays the 'Video' configuration window, which is organized into three main sections for stream configuration and one for BNC output. Each stream configuration section includes a 'Video Compression' dropdown, 'Resolution' and 'Frame Rate(fps)' dropdowns, a 'Bit Rate(Kbps)' text input, a 'Bitrate Type' dropdown, and an 'Image Quality' slider with 'Bit Rate' and 'Quality' labels. Below these are 'I Frame Interval' and 'GOP' dropdowns, and a 'Smoothing' slider with 'Clear' and 'Smooth' labels. The 'Smart Encoding' dropdown is set to 'Off' for all streams. The 'Enable Third Stream' checkbox is checked. The 'BNC Output' section has a 'Mode' dropdown set to 'PAL'. A 'Save' button is located at the bottom left.

Stream	Video Compression	Resolution	Frame Rate(fps)	Bit Rate(Kbps)	Bitrate Type	I Frame Interval	GOP	Smoothing	Smart Encoding
Main	H.265	2048×1536	30	3072	VBR	60	IP	Clear	Off
Sub	H.264	640×360	30	1024	VBR	60	IP	Clear	Off
Third	H.264	640×360	25	1024	VBR	50	IP	Clear	Off

BNC Output Mode: PAL

Figure 4-15

The following options are available for the main, sub and third streams.

- **Video Compression:** Set the codec type to **H.264** or **MJPEG** (for **GV-SD2322-IR**), or to **H.265**, **H.264** or **MJPEG** (for **GV-SD2722-IR / SD3732-IR**).
- **Resolution:** You may select the different resolutions for each stream.
- **Frame Rate:** Select a frame rate for encoding images. The unit is frame per second.

- **Bit Rate:**
 - **CBR:** The camera transmits data at a constant data rate by varying the quality of the stream
 - **VBR:** The quality of the video stream is kept as constant as possible at the cost of a varying bitrate.
- **Image Quality:** When VBR is selected for the encoding mode, you can move the slider to adjust quality level for images. Moving the slider toward **Bit Rate** decreases the bit rate and may affect image quality. Moving the slider toward **Quality** increases the bit rate and improves image quality.
- **I Frame Interval:** Set the number of frames between each I frame (key frame). This option is only available when H.265 or H.264 is selected for codec.
- **GOP:** The GOP is IP by default.
- **Smoothing:** Set the extent of smoothing. Choosing **Clear** disables **Smoothing**. Moving the slider toward **Smooth** increases the level of smoothing but will affect image quality.
- **Smart Encoding:** Reduce the bitrate for smoother transmission. Choosing Basic Mode disables **I Frame Interval** and **Smoothing**.

[BNC Output] The status of the BNC device is shown.

- **Mode:** Set the signal format of the video output to either **NTSC** or **PAL**.

4.3.2 Audio

You can configure the audio settings of the camera.

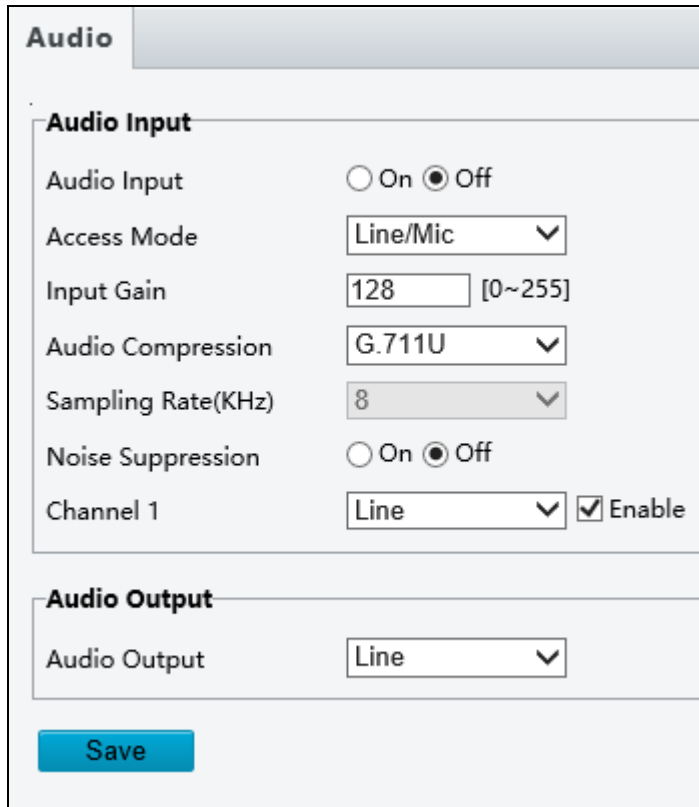

Figure 4-16

The following options are available.

- **Audio Input:** Select **ON** to enable audio input.\
- **Input Gain:** Set the audio signal amplification for sampling. The greater the gain, the greater amplification
- **Audio Compression:** Select an audio codec.

The functions below are only applicable to **GV-SD2722-IR / SD3732-IR**.

- **Noise Suppression:** Select **On** to reduce the noise of the audio.
- **Channel 1:** Click Enable to enable audio in through the camera's built-in microphone.
- **Audio Output:** Select the source of audio output.

4.3.3 Snapshot

This function is only applicable to **GV-SD2722-IR / SD3732-IR**.

Using the Snapshot function, when an alarm is triggered, the camera will automatically upload the captured snapshots to the FTP server or send snapshots to the specified e-mail address.

Note: If **Upload Images** is selected in *Figure 4-56, 4.8.3 FTP*, the captured snapshots will only be sent to the FTP server.

Figure 4-17

1. Select On to enable **Snapshot**.
2. Select the **Resolution**.
3. Specify the maximum size (1~800 KB) of the snapshot image under **Most Large**.
4. Specify the length of interval (1~60 sec) between snapshots under **Snapshot Interval(s)**.
5. Choose the **Number** (of snapshot) to **Snapshot** upon alarm trigger.
6. Select **Schedule** or **Repeat** to set up the **Snapshot Mode**.
 - If you select **Schedule**, click  to specify the desired time to take a snapshot.
 - If you select **Repeat**, type the interval, from 1 to 86400 seconds, to repeat the process of taking snapshots and sending them to the FTP server or e-mail.
7. Click **Save**.

4.3.4 ROI

When Region of Interest (ROI) is enabled, the system ensures image quality for ROI first if the bit rate is insufficient. Note this function is only applicable to **GV-SD2722-IR / SD3732-IR**.

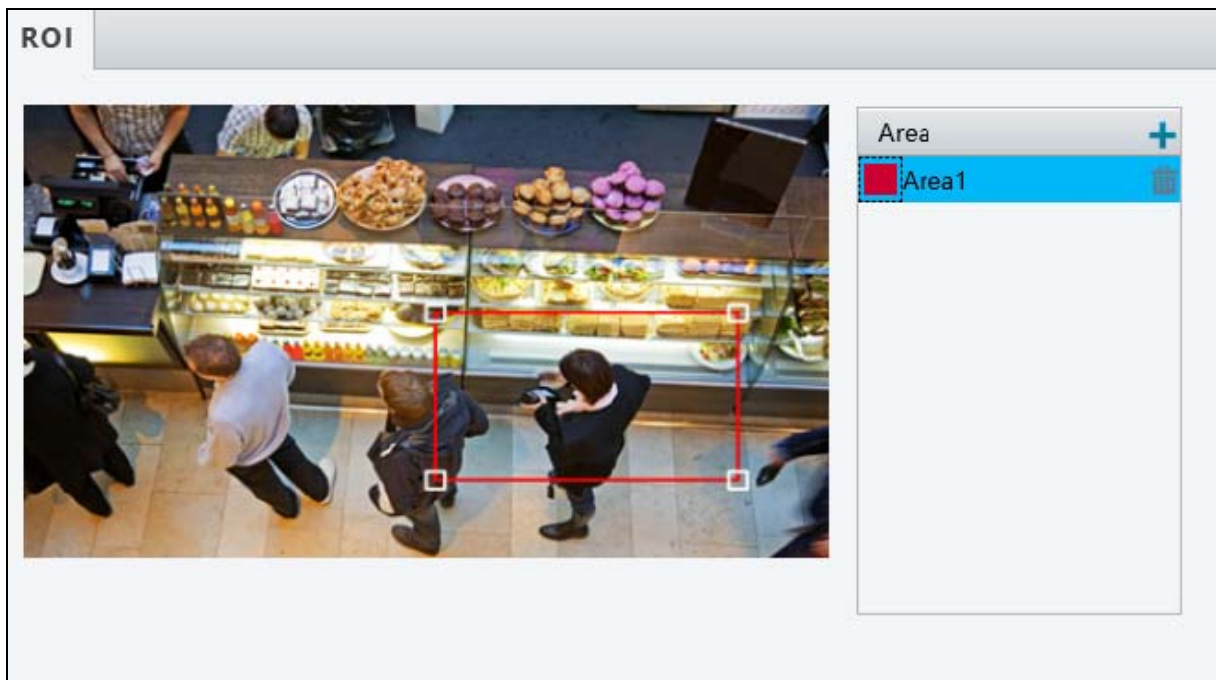



Figure 4-18

1. Click  to enable and add ROI.
2. Click and drag on the image to specify an area.
3. To add additional ROI areas, repeat steps 1 and 2. Up to eight ROI areas can be specified.
4. To delete an ROI area, click .

4.3.5 Media Stream

Note this function is only applicable to **GV-SD2722-IR / SD3732-IR**.

Media Stream

By configuring media stream, you can set the camera to transmit code streams by UDP or TCP protocol to a specified IP address and port number. The settings can be saved and take effect after the camera is restarted.

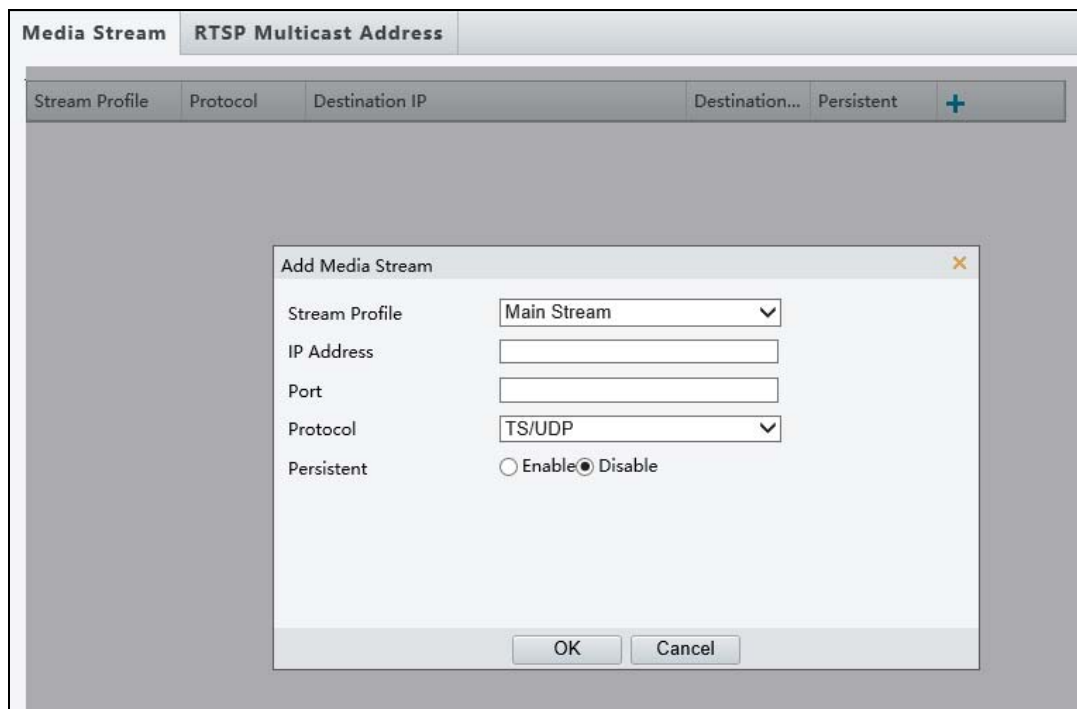



Figure 4-19

1. Click **+** and then select a type in the **Stream Profile**.
2. Type the **IP Address** and **Port** number of the unicast or multicast group for the decoding device that receives audio and video streams from the camera.
3. If you want the device to establish the media stream that has been configured before automatically after the restart, select **Yes / Enable** for **Persistent**.
4. To delete a stream, click .
5. Click **Submit** to complete the settings.

RTSP Multicast Address

After an RTSP multicast address is configured, the third-party player can request the RTSP multicast media stream from the camera through the RTP protocol.

Media Stream	RTSP Multicast Address
Main	
Multicast Address	<input type="text" value="238.254.254.254"/>
Port	<input type="text" value="65500"/>
Sub	
Multicast Address	<input type="text" value="0.0.0.0"/>
Port	<input type="text" value="0"/>
Third	
Multicast Address	<input type="text" value="0.0.0.0"/>
Port	<input type="text" value="0"/>
<input type="button" value="Save"/>	

Figure 4-20

1. Type the **Multicast Address** (224.0.0.0 to 239.255.255.255) and **Port** number (0 to 65535).
2. Click **Save**.

For RTSP Multicast command, see *Appendix A*.

4.4 PTZ

4.4.1 Home Position

You can set the camera to return to home position if no operation is made within a specified period. For detailed instructions, refer to 3.2 *Setting Home Position*.

4.4.2 PTZ Limit

Users can set PTZ limitations to prevent the camera from hitting obstacles such as walls. Note this function is only applicable to **GV-SD2722-IR / SD3732-IR**.

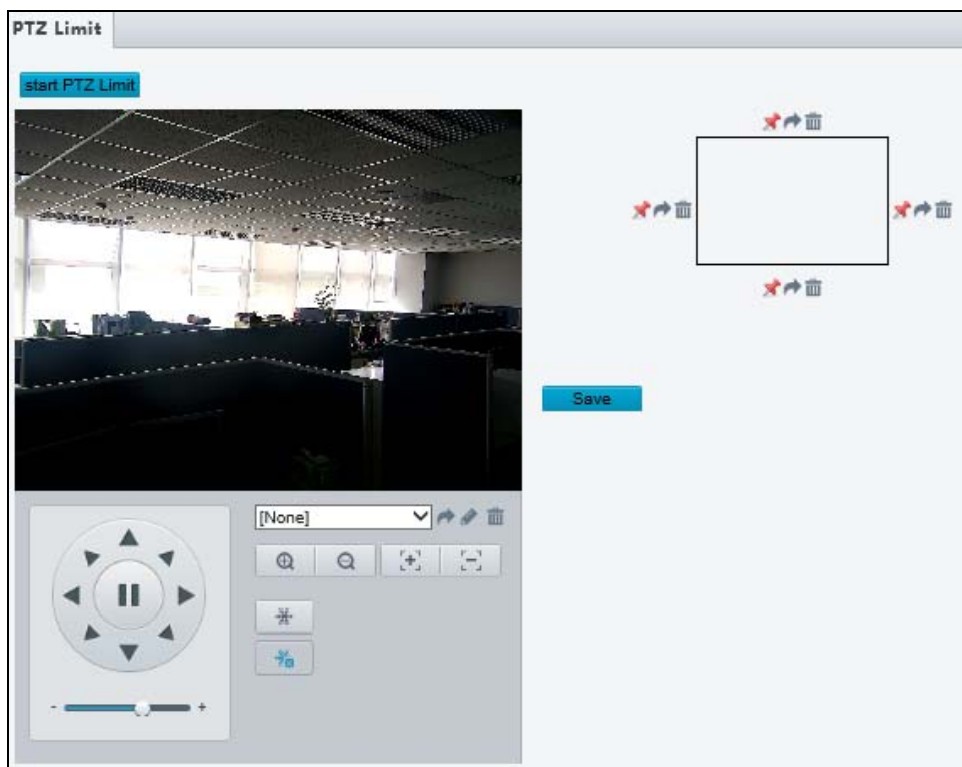



Figure 4-21

1. Click **start PTZ Limit** to enable.
2. Adjust the dome view in such a way that it reaches the PTZ limit you want to set.
3. Click  to set the position relative to the current dome view as a limit. For example, click the  at the top to set the upper limit.
4. Repeat Step 2 & 3 to set all limits as needed and click **Save**.

4.4.3 Remote Control

Note this function is only applicable to **GV-SD2722-IR / SD3732-IR**.

You can connect a third-party PTZ remote control program to your GV-IP Speed Dome once this function is enabled.

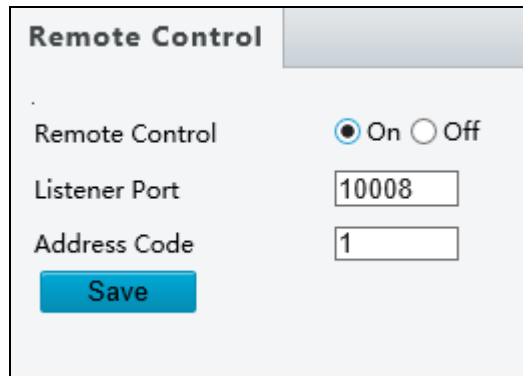

Figure 4-22

1. Specify the **Listener Port** to which the third-party PTZ remote control program connects.
2. Assign an individual **Address Code** (between 0 ~ 255) to each PTZ remote control program
3. Click **Save**.

Note: For this function, your router needs to support **port forwarding**.

4.4.4 Patrol

Note this function is only applicable to **GV-SD2722-IR / SD3732-IR**.

You can set the camera to take a snapshot and upload the image to the FTP server when the camera goes to the preset during the patrol route.

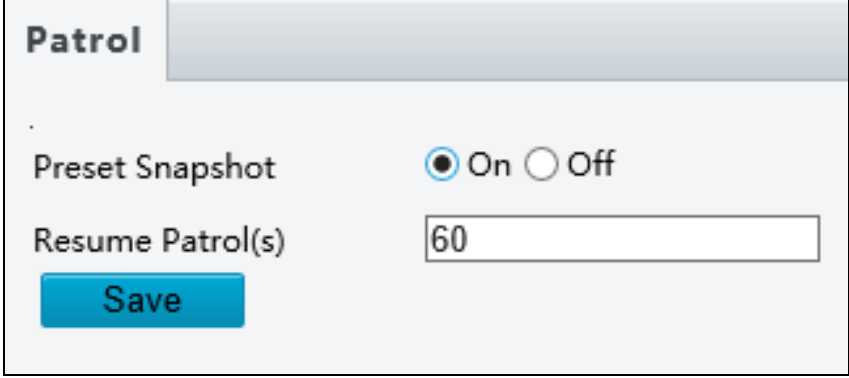

Patrol

Preset Snapshot On Off

Resume Patrol(s)

Save

Figure 4-23

1. Enable **Preset Snapshot**.
2. Type the Resume Patrol(s) interval in seconds to upload snapshots.
3. Click **Save**.

Note: For this function, make sure to configure the settings in [4.8.3 FTP first](#).

4.5 Image

This section introduces the Image Settings, On-screen Display, and Privacy Mask.

4.5.1 Image

This page allows you to adjust image settings such as brightness, exposure, IR illumination and white balance.

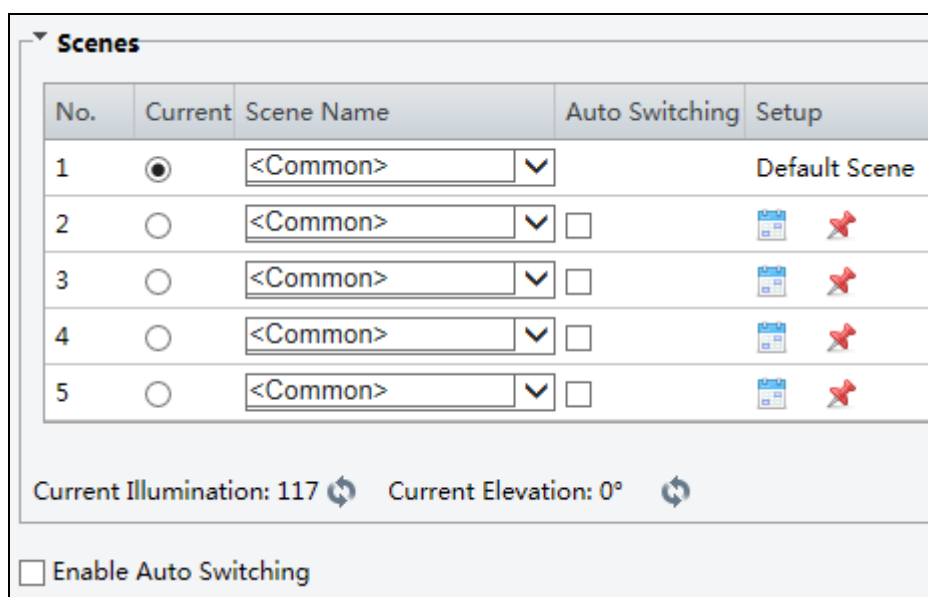

Figure 4-24

[Scene]

- **Current:** Indicates the scene that is being used.
- **Screen Name:** When you select a scene, the corresponding image parameters are displayed. You can adjust image settings according to actual needs.
- **Auto Switching:** Indicates whether to add a scene to the auto-switching list.
- **Setup:**
 - Click to set a schedule for auto-switching, including schedule, illumination, and current elevation (angle between the PTZ and the horizontal direction).
 - Click to set a scene as the default scene.
- **Enable Auto Switching:** Allow the camera can switch to the scene automatically when the condition for switching to a non-default scene is met.

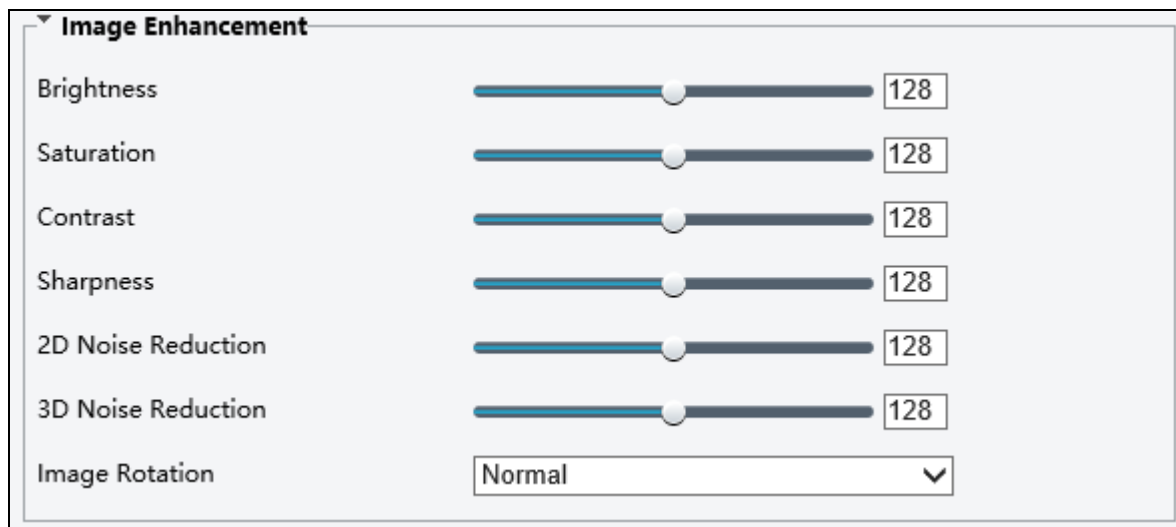

Figure 4-25

[Image Enhancement]

- **Brightness:** Adjust the degree of brightness of the image.
- **Saturation:** Adjust the amount of a hue contained in a color.
- **Contrast:** Set the degree of difference between the blackest pixel and the whitest pixel.
- **Sharpness:** Adjust the sharpness of the image.
- **2D / 3D Noise Reduction:** Reduce the noise of the image.
- **Image Rotation:** Change the rotation of the image.

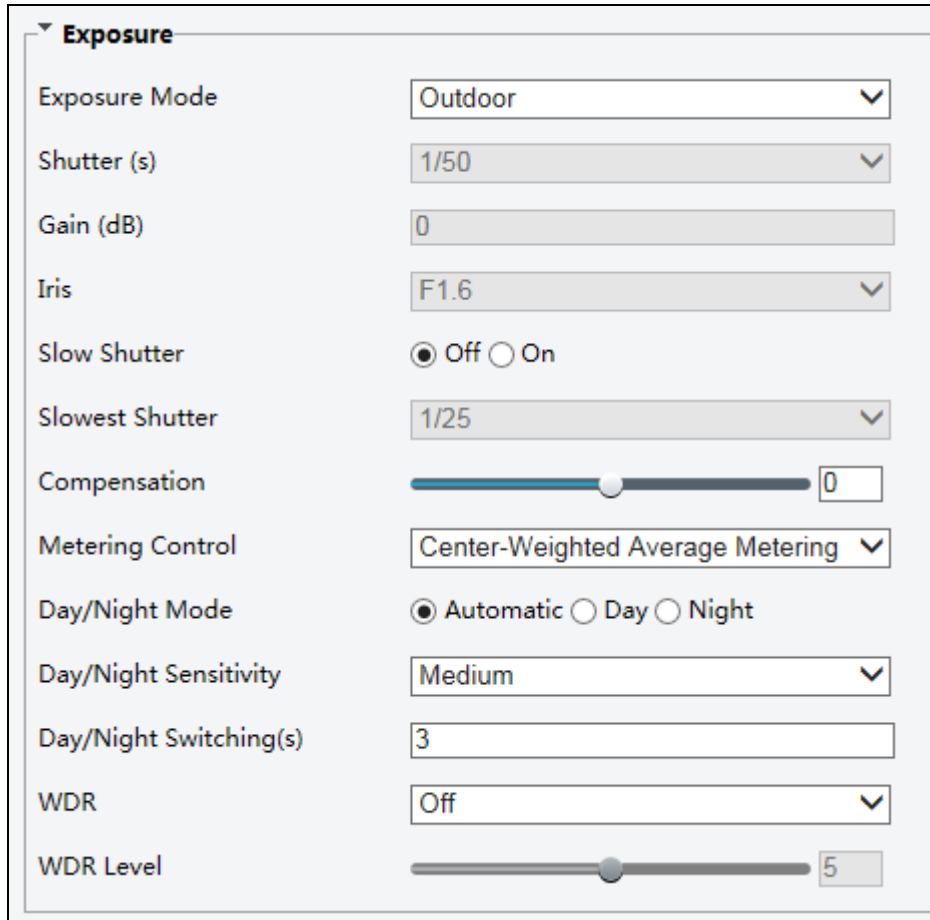

Figure 4-26

[Exposure]

- **Exposure Mode:** Select the correct exposure mode to achieve the desired exposure effect. The default setting is Outdoor with a frequency of 50 Hz.
- **Shutter (s):** The length of time that allows light to enter into the lens. You can set a shutter speed when **Exposure Mode** is set to **Manual (Custom)** or **Shutter Priority**.

Note: If **Slow Shutter** is set to **Off**, the reciprocal of the shutter speed must be greater than the frame rate.

- **Gain (dB):** Control image signals so that the camera outputs standard video signals according to the light condition. You can set this parameter only when **Exposure Mode** is set to **Manual (Custom)** or **Gain Priority**.
- **Iris:** Sets the aperture size of the lens. This function is only applicable to **GV-SD2322-IR**.

- **Slow Shutter:** Improve image brightness in low light conditions. For **GV-SD2322-IR**, you can only set this parameter when **Exposure Mode** is not set to **Shutter Priority** and when **Image Stabilizer** is disabled.
- **Slowest Shutter:** Set the slowest shutter speed that the camera can use during exposure.
- **Compensation:** Adjust the compensation value as required to achieve the desired effects. You can set this parameter only when **Exposure Mode** is not set to **Manual (Custom)**.
- **Metering Control:** Set the way the camera measures the intensity of light. You can only set this parameter when **Exposure Mode** is not set to **Manual (Custom)**.
 - ⊙ **Center-Weighted Average Metering:** Measure light mainly in the central part of images.
 - ⊙ **Evaluative Metering (BLC):** Measure light in the customized area of images.
 - ⊙ **Face Metering:** Measure light where facial recognition is established.
 - ⊙ **Spot Metering:** Measure light spot(s) in the specified area of the images.
 - ⊙ **Highlight compensation:** Ignore the brightness of the overexposed area of images. But selecting this setting will decrease the overall brightness of the image. This function is applicable only to **GV-SD2322-IR**.
- **Day/Night Mode:** Select **Automatic** for automatic switch between day mode and night mode depending on the amount of light detected. Select **Night** to produce high-quality black and white images using the existing light. Select **Day** to produce high-quality color images using the existing light.
- **Day/Night Sensitivity:** Set the light threshold for switching between day mode and night mode. A higher sensitivity means that the camera is more sensitive to the change of light and becomes more easily to switch between day mode and night mode.
- **Day/Night Switching(s):** Set the length of time before the camera switches between day mode and night mode after the conditions for switching are met.
- **WDR:** Enable WDR to distinguish the bright and dark areas in the same image.
- **WDR Level:** After enabling the WDR function, you can improve the image by adjusting the WDR level.
- **Suppress WDR Stripes:** Enable Suppress WDR Stripes to automatically adjust shutter frequency based on the frequency of light measured.

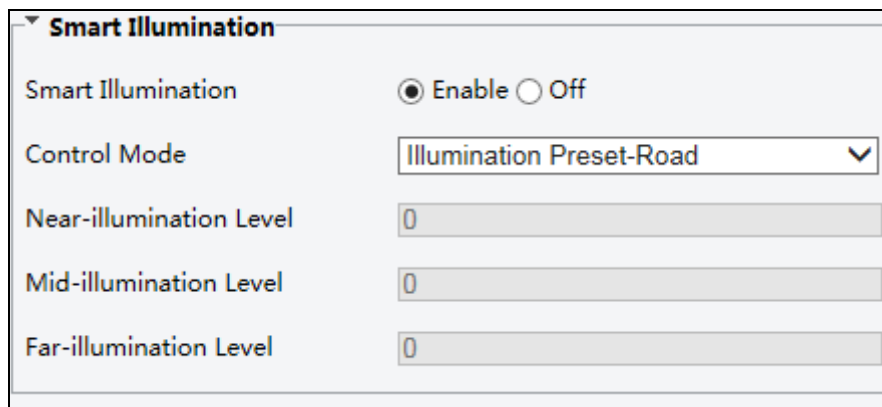

Figure 4-27

[Smart Illumination]

- **Smart Illumination:** Select **Enable** to adjust the IR illumination settings.
- **Control Mode:**
 - ⊙ **Global Mode:** (The function is only applicable to **GV-SD2322-IR.**) Adjust IR illumination and exposure to achieve balanced image effects. Some areas might be overexposed if you select this option. This option is recommended if monitored range and image brightness are your first priority.
 - ⊙ **Overexposure Restrain:** (The function is only applicable to **GV-SD2322-IR.**) Adjust IR illumination and exposure to avoid regional overexposure. Some areas might be dark if you select this option. This option is recommended if clarity of the central part of the image and overexposure control are your first priority.
 - ⊙ **Illumination Preset-Road / Road:** Offer strong illumination in whole and is recommended for monitoring wide-ranging scenes, for example, road.
 - ⊙ **Illumination Preset-Park / Park:** Offer uniform light and is recommended for monitoring small range scenes with many obstacles, for example, industrial parks.
 - ⊙ **Manual:** (The function is only applicable to **GV-SD2322-IR.**) Allow you to manually control the intensity of IR illumination.
- **Illumination Level:** Set the intensity level of the IR light. The greater the value, the higher the intensity. 0 means that the IR light is turned off. When Control Mode is set to Manual, you can set the intensity level of the IR light.

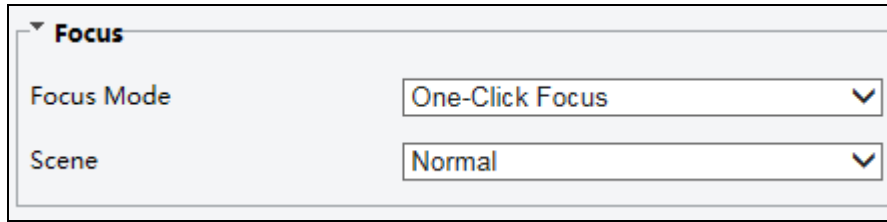

Figure 4-28

[Focus]

■ Focus Mode:

- ⊙ **Auto Focus:** Focuses automatically according to the current light condition.
- ⊙ **Manual Focus:** Manually adjust camera focus as required.
- ⊙ **One-Click Focus:** The camera is triggered to focus once when rotating, zooming or going to a preset.
- ⊙ **One-Click Focus (IR):** In a low light condition such as during night hours or in a dark house, this focus mode achieves better effects with the IR light turned on.

■ Scene:

- ⊙ **Normal:** Used for common scenes, such as road and industrial park.
- ⊙ **Long distance:** Used for long-distance monitoring on a road.

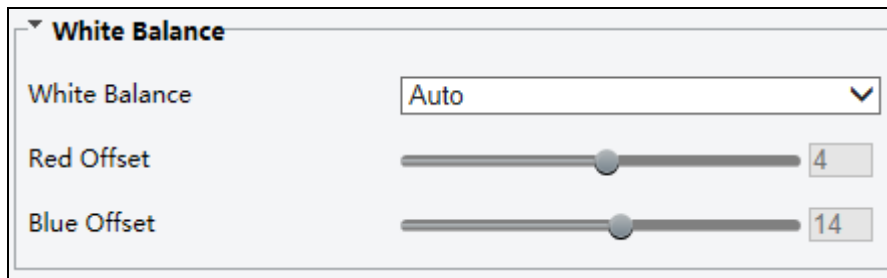

Figure 4-29

[White Balance]

- **White Balance:** Adjust the red or blue offset of the image.
 - ⊙ **Auto:** Adjust the red and blue offset automatically according to the light condition (the color tends to be blue).
 - ⊙ **Outdoor:** (The function is only applicable to **GV-SD2722-IR / SD3732-IR**). It is recommended for outdoor scenes with a wide range of color temperature variation.
 - ⊙ **Fine tune:** Allow you to adjust the red and blue offset manually.
 - ⊙ **Sodium / Sodium Lamp:** Adjust the red and blue offset automatically according to the light condition (the color tends to be red).\
 - ⊙ **Locked:** (The function is only applicable to **GV-SD2722-IR / SD3732-IR**). Lock the current color temperature settings without adjustment.

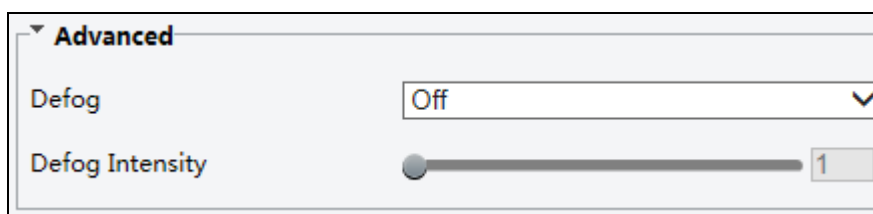

Figure 4-30

[Advanced]

- **Defog:** Select **Digital** (for **GV-SD2322-IR**) or **ON** (for **GV-SD3732-IR**) to activate the slider for adjusting the **defog intensity** for images.
- **Image Stabilizer:** Enable **EIS** (Digital Image Stabilization).

4.5.2 OSD

On Screen Display (OSD) is the text displayed on the screen with video images and may include time and other customized contents.

For GV-SD2322-IR

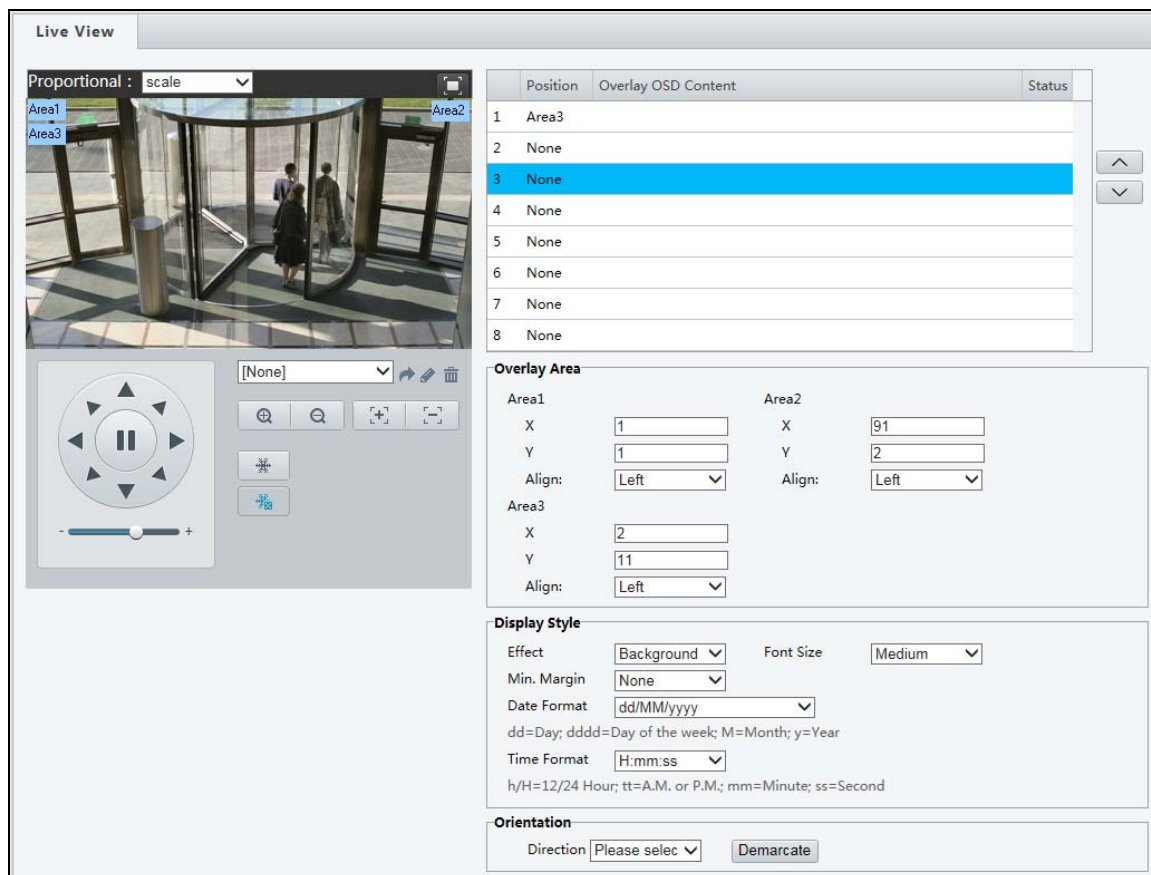

Figure 4-31

1. Click under **Position** to select an Area #, and then click **Overlay OSD Content** to select the content to display on screen.

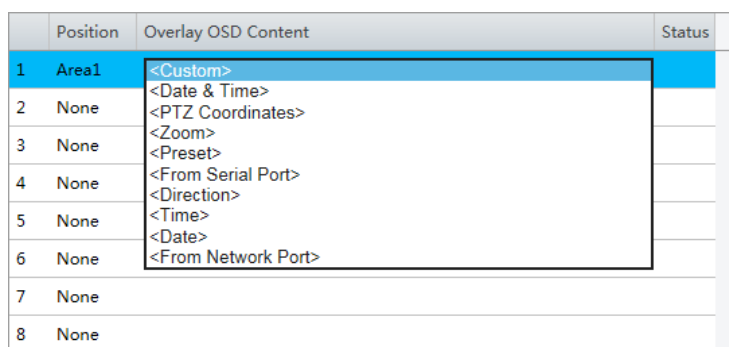





Figure 4-32

2. Adjust the position of the Area 1/2/3 boxes on the live view either by dragging directly or by specifying the coordinates under **Overlay Area**.
3. Under **Display Style**, customize the text style and date/time format.
4. Under **Orientation**, use the **Direction** drop-down list to select a direction, turn the camera toward the corresponding direction, and click **Demarcate**.

After you have set the position and OSD content, the  symbol appears in the **Status** column, which means that the OSD is set successfully. You may set multiple lines of contents for each area and use  and  to adjust the sequence of display.

For GV-SD2722-IR / SD3732-IR

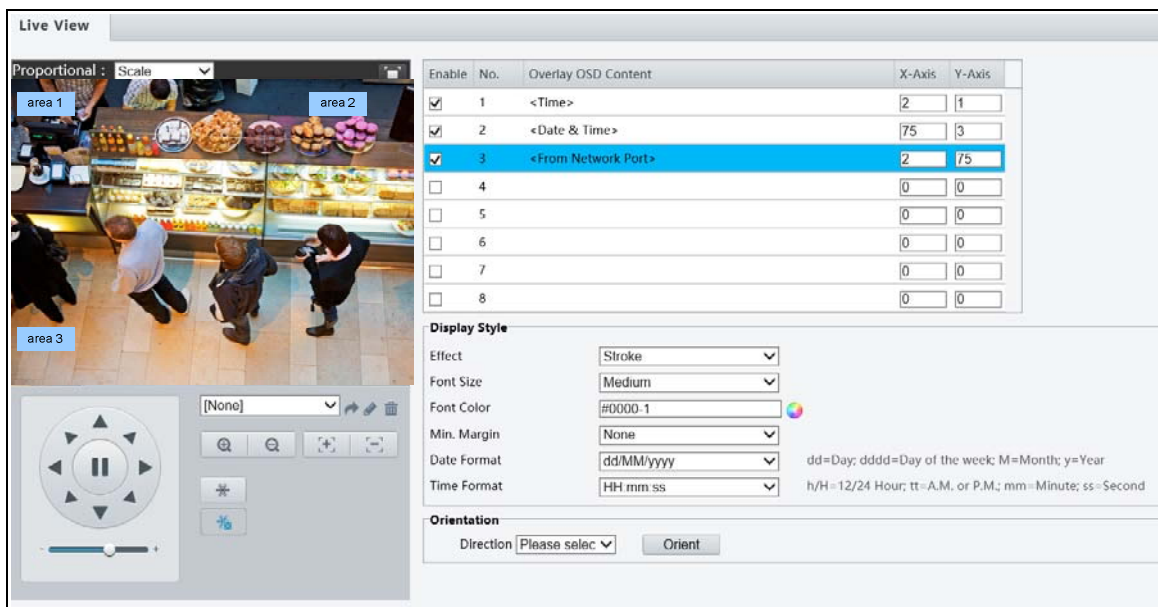



Figure 4-33

1. Enable a **No.** to select an area #, and then click **Overlay OSD Content** to select the content to display on screen.
2. Adjust the position of the Area 1/2/3 boxes on the live view either by dragging directly or by specifying the coordinates under the **X-Axis / Y-Axis** column.
3. Under **Display Style**, customize the text style and date/time format.
4. Under **Orientation**, use the **Direction** drop-down list to select a direction, turn the camera toward the corresponding direction, and click **Orient**.

After you have set the position and OSD content, the  symbol appears in the **Status** column, which means that the OSD is set successfully.

4.5.3 Privacy Mask

On certain occasions, you may need to set a mask area to block out parts of the camera image to protect privacy, for example, the keyboard of an ATM machine. When PTZ changes its position or zooms, the Privacy Mask will be adjusted accordingly to protect the area all along.

No.	Name	Max. Zoom	Panel
1	Mask1	<input type="text" value="1.00"/>	<input type="button" value="Set As Max."/> <input type="button" value="Preset"/>

Figure 4-34

1. Click to add a privacy mask.
2. Click the box (with **Mask** displayed on it) to activate the mask.
3. Drag the box to the intended position and adjust the size of the box. Alternatively, you can also use the mouse to draw a box on the area you want to mask.
4. To delete a mask, click .

To quickly locate a mask on the camera view, select a mask and click **Preset** to turn the camera toward the masked area. If the masked area is small, you can zoom in to the appropriate level, and click **Set as Max** to mark the zoom level for future reference.

4.6 Intelligent

Note this function is only applicable to **GV-SD2722-IR / SD3732-IR**.

The Intelligent functions allow the camera to track moving people and/or object in a predefined area and trigger warnings, such as when the person trespasses a detection threshold, or attempts to breach into a detection zone set.

Enabling the **Auto Tracking** function causes other Intelligent functions to be disabled and vice versa.

4.6.1 Smart Settings

To achieve optimal tracking results, it is recommended to firmly install the camera at a certain height in an open space. It is also essential to arrange proper lighting conditions to avoid high contrast and backlighting that obscures the target.

There are certain limitations that causes ineffective tracking:

- **Number of the targets:** The camera can only track one person at a time. When more than one people walks into the detection area, only the first person entering the scene is tracked. When the specified tracking time is over, the camera then continues to track the second person.
- **Obstructions:** When the target is blocked behind other objects while walking through the detection zone during tracking, the target will be lost.

4.6.2 Cross Line

Cross line detection generates an alarm when an object moves past the detection threshold in the direction you defined. Up to 4 detection lines can be added. Note that when adding multiple detection lines, make sure they do **NOT** intersect as it may affect the detection results. Select the checkbox next to **Cross Line** to enable and click  to configure.

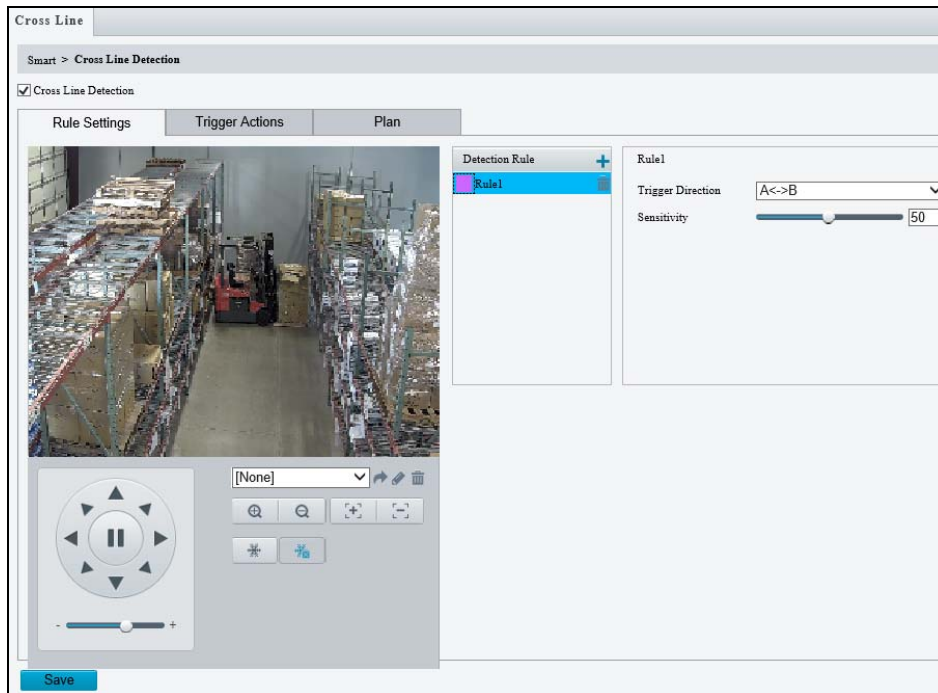
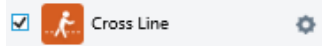



Figure 4-35

1. Once enabled, click  to add a detection line. Repeat to add another detection line.
2. Drag the ends of the detection line to the intended position to mark the detection boundary.
3. Select the **Trigger Direction**, which will define the direction to trigger an alarm. For example, if you choose **A -> B**, people moving from direction A to B will trigger an alarm.
4. You can move the slider to adjust the detection **Sensitivity**.
5. **Trigger Actions:**

Rule Settings	Trigger Actions	Plan	
<input type="checkbox"/> Upload to FTP <input type="checkbox"/> Send E-mail	<input type="checkbox"/> Alarm Output <input type="checkbox"/> A → 1	<input type="checkbox"/> Recording Edge Storage <input type="checkbox"/> Image Edge Storage	<input type="checkbox"/> PTZ <input type="checkbox"/> Trigger Tracking

Figure 4-36

- ⊙ Select **Upload to FTP** and/or **Send E-mail** under **Trigger Actions** to automatically upload snapshots to the specified FTP server and/or send snapshots to the specified e-mail address upon the video analytic events.
 - ⊙ Select **A -> 1** to trigger an output device after alarm output is triggered by a motion detection alarm, temperature alarm or input alarm.
 - ⊙ Select **Recording Edge Storage** or **Image Edge Storage**. Snapshots captured will automatically be stored in the selected storage(s).
 - ⊙ Select **Trigger Tracking** to track the object until the object is out of view.
6. Optionally select **Enable Plan** under **Plan** to set the start and end times during which the video analytic monitoring is enabled. You can directly drag the mouse to draw a plan or click **Edit** to edit time periods in the table. You can set up to four periods for each day, and the time periods cannot overlap. The camera reports alarms during the specified period only.

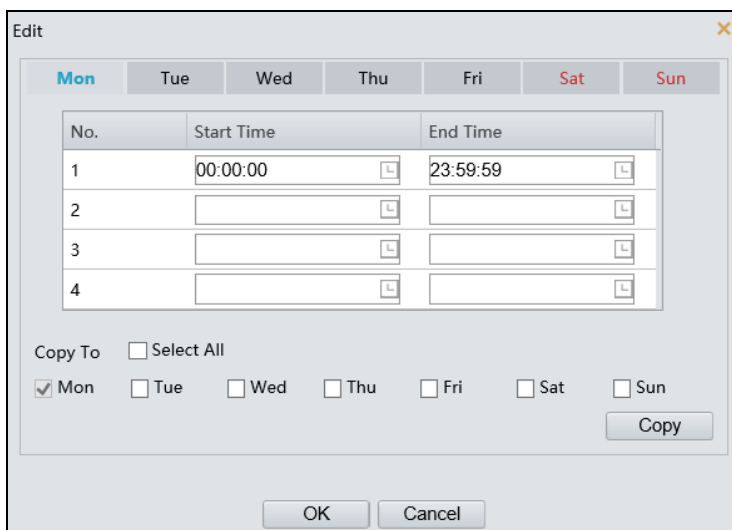
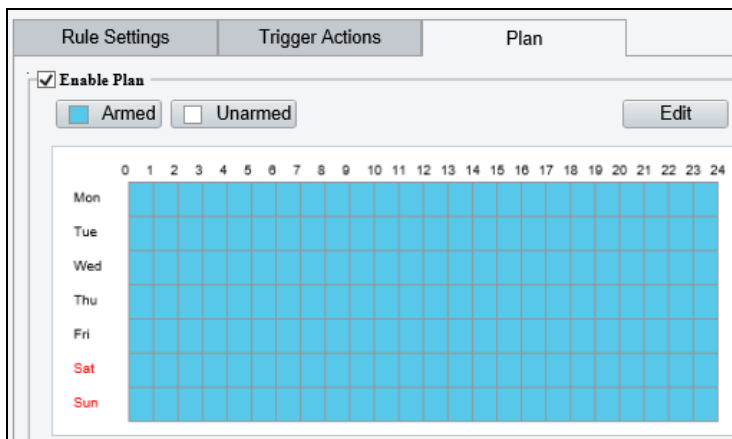



Figure 4-37

4.6.3 Intrusion

With Intrusion Detection, an alarm is generated when an object enters the boundaries of the detection area. Up to 4 detection areas can be added. Note that it is recommended **NOT** to overlap the detection areas when adding multiple detection areas. Select the checkbox next to **Intrusion** to enable and click  to configure.

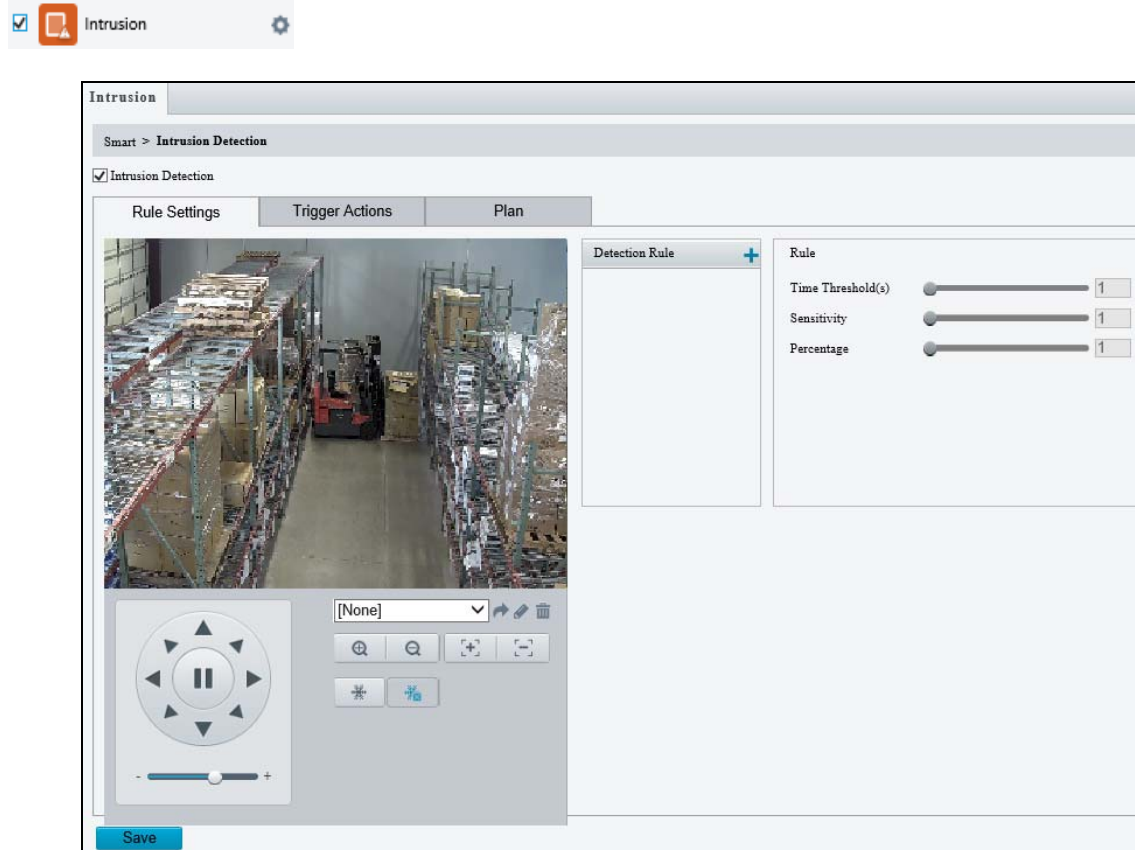



Figure 4-38

1. Once enabled, click  to mark the live view with a detection area. Repeat this step to add another detection area.
2. Drag the nodes of the detection area to mark the boundary for detection.
3. You can use the following functions to reduce false alarm.
 - ⊙ **Time Threshold:** The minimum period of time for a person to stay within the detection area before an alarm is triggered.
 - ⊙ **Sensitivity:** Move the slider to adjust the detection
 - ⊙ **Percentage:** Type the minimum size of the person compared to the detection area for the person to be detected.
4. For **Trigger Actions** and **Plan**, follow *Step 5 ~ 6, 4.6.2 Cross Line*.

4.6.4 Object Removed

Object Removed can generate an alarm when an object is removed from the specified area. Up to 4 detection areas can be added. Note that it is recommended **NOT** to overlap the detection areas when adding multiple detection areas. Select the checkbox next to **Object Removed** to enable and click  to configure.

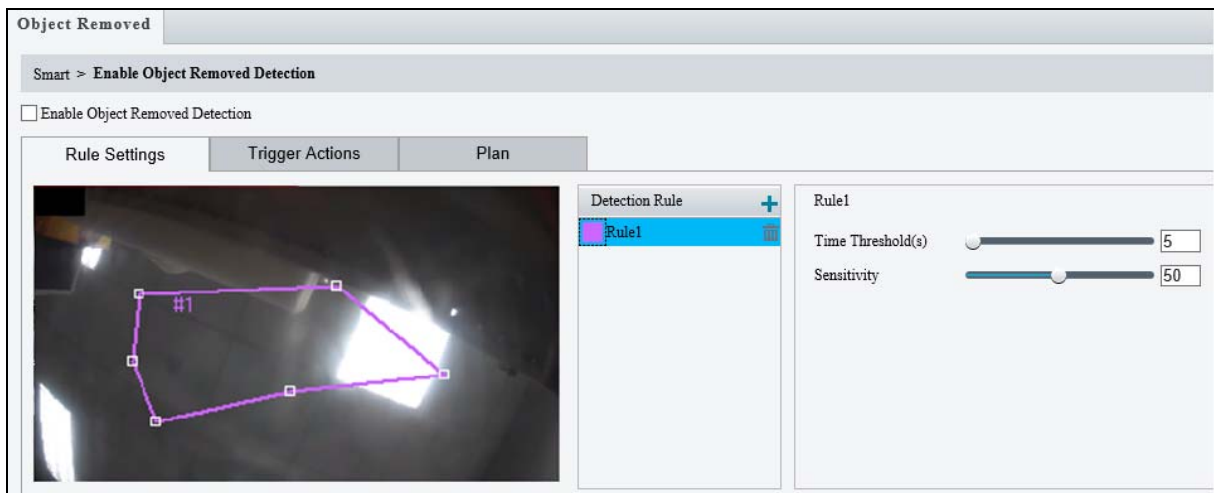
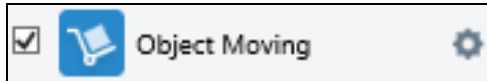



Figure 4-39

1. Once enabled, click  to mark the live view with a detection area. Repeat this step to add another detection area.
2. Drag the nodes of the detection area to mark the boundary for detection.
3. You can use the following functions to reduce false alarm.
 - ⊙ **Time Threshold:** The minimum period of time for an object to be absent from the detection area before an alarm is triggered.
 - ⊙ **Sensitivity:** Move the slider to adjust the detection
4. For **Trigger Actions** and **Plan**, follow *Step 5 ~ 6, 4.6.2 Cross Line*.

4.6.5 Object Left Behind

With Object Left Behind, an alarm can be generated when an object which remained in the detection area for the specified period of time, leaves the specified region. Up to 4 detection areas can be added. Note that it is recommended **NOT** to overlap the detection areas when adding multiple detection areas. Select the checkbox next to **Object Left Behind** to enable and click  to configure.

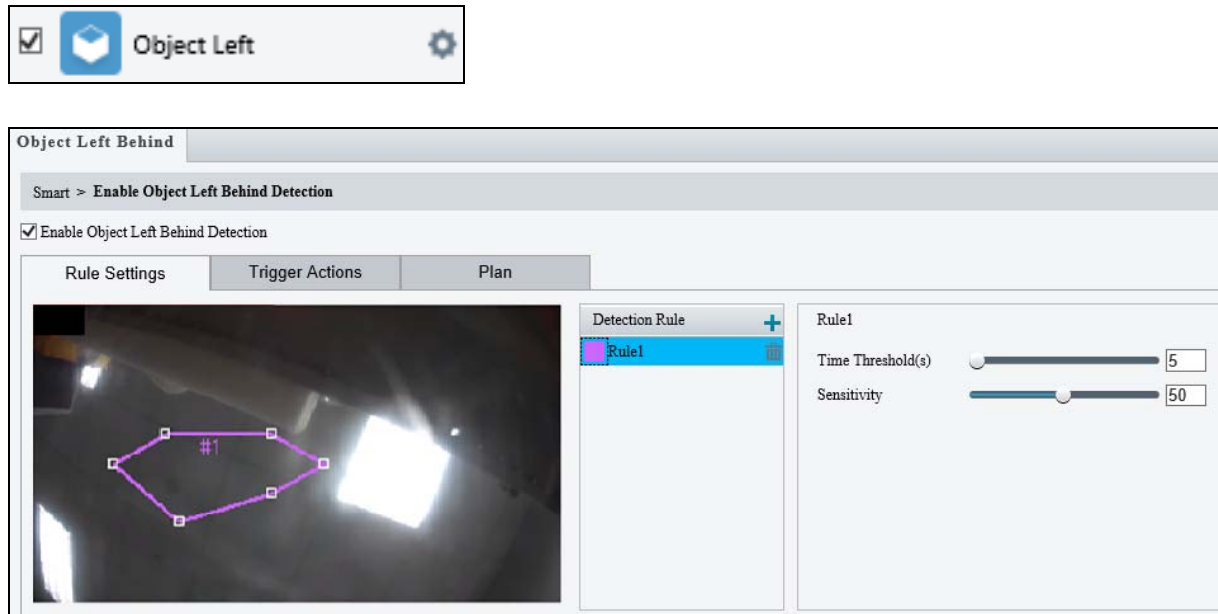



Figure 4-40

1. Once enabled, click  to mark the live view with a detection area. Repeat this step to add another detection area.
2. Drag the nodes of the detection area to mark the boundary for detection.
3. You can use the following functions to reduce false alarm.
 - ⊙ **Time Threshold:** The minimum period of time for a moving object to stay within the detection area before an alarm is triggered.
 - ⊙ **Sensitivity:** Move the slider to adjust the detection
4. For **Trigger Actions** and **Plan**, follow Step 5 ~ 6, 4.6.2 Cross Line.

4.6.6 Face Detection

The Face Detection function can detect for and capture faces to be sent to an FTP server. Select the checkbox next to **Face** to enable and click  to configure.

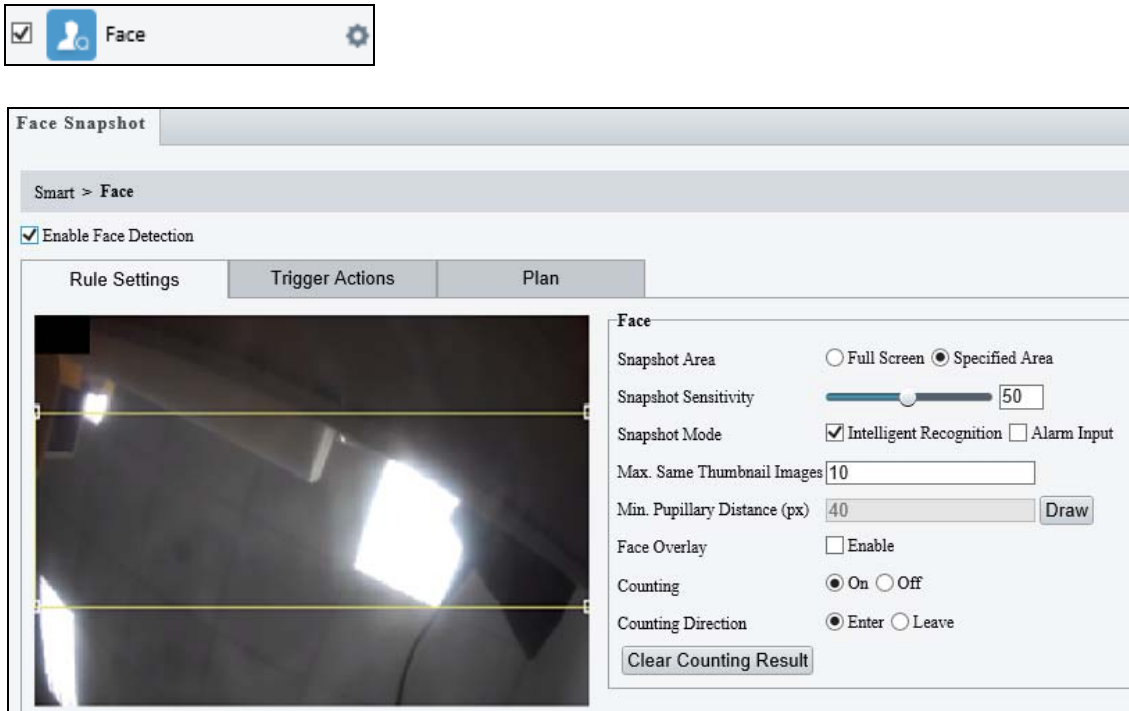



Figure 4-41

1. Once enabled, define the detection area, either by drawing a desired area on the image or select **Full Screen** next to **Specified Area** to set the entire image as detection area.
2. Configure the following functions as needed:
 - ⊙ **Snapshot Sensitivity:** Drag the slider to adjust the detection sensitivity.
 - ⊙ **Snapshot Mode:** Select **Intelligent Recognition** to set the maximum of repeated face snapshots (1~30) for **Max. Same Thumbnail Image**.
 - ⊙ **Min. Pupillary Distance (px):** Click **Draw** and draw in the live view window.
 - ⊙ **Face Overlay:** Enable to include the camera's text overlay on the snapshot(s) captured.
3. Under **Trigger Actions**, select **Upload Image(Original)** to upload a snapshot of the entire image and a snapshot of the face detected upon face detection. Select **Upload Image(Target)** to upload only the snapshot of the face detected.
4. For **Plan**, follow *Step 6, 4.6.2 Cross Line*.

Note: The **Counting** and **Counting Direction** features are currently nonfunctional.

4.6.7 People Counting

The People Counting function can count the number of person(s) entering and leaving the vicinity, which is useful at an entrance/exit setting. Select the checkbox next to **People Counting** to enable and click  to configure.

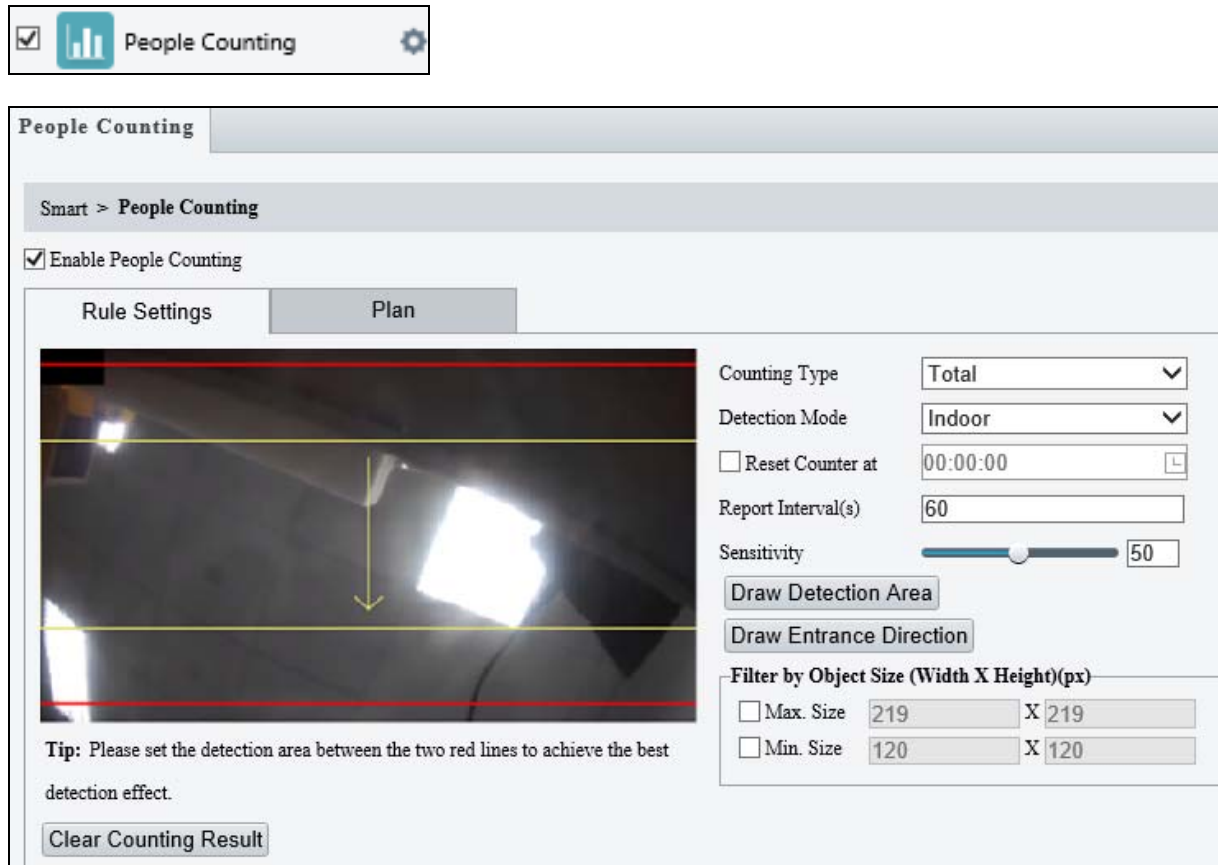

Figure 4-42

1. Once enabled, draw a detection area and entrance direction on the image by clicking **Draw Detection Area** and **Draw Entrance Direction**, respectively.
2. Select the desired **Counting Type**, from Total, People Entered or People Left.
3. Select a **Detection Mode**, between Indoor and Outdoor, depending on your environment.
4. Under **Filter by Object Size**, set the **Max. Size** and **Min. Size** of the objects to be counted.
5. Optionally select **Reset Counter at** to set a time within a day when to reset the counter.
6. You can adjust the detection sensitivity by dragging the **Sensitivity** slider.
7. For **Plan**, follow *Step 6, 4.6.2 Cross Line*.

4.6.8 Auto Tracking

Auto Tracking allows you to track moving object(s) for as long as 300 seconds.

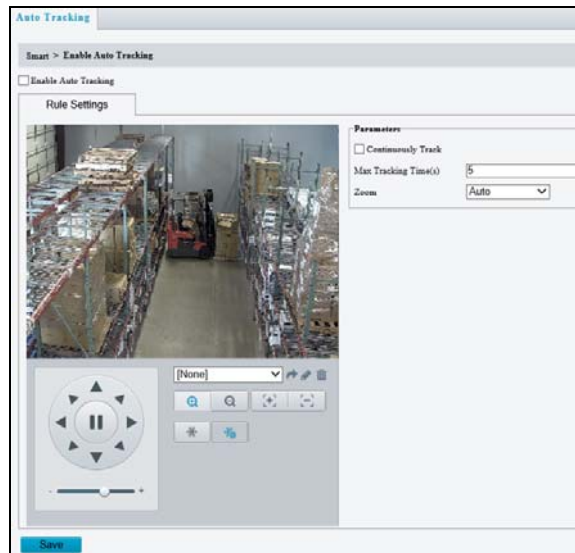

Figure 4-43

1. Enable **Auto Tracking**.
2. Enable **Continuously Track** for round-the-clock tracking.
3. Type the amount of time for the camera to keep tracking moving objects in the **Tracking Timeout(s)** field.
4. Select one of the following for **Zoom**.
 - Ⓐ **Auto**: The camera automatically zooms in on the moving objects upon tracking.
 - Ⓑ **Current Zoom**: The camera remains in its current zoom level when tracking moving objects.

4.6.9 Advanced Settings

This section allows you to configure the clarity of the snapshots captured by face detection events and choose the detection modes used for all video-analytic events.

Photo Parameters

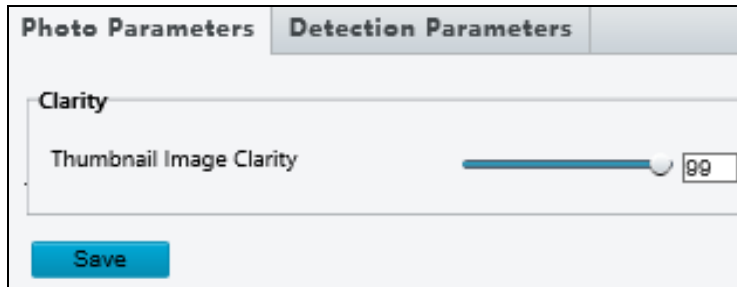

Figure 4-44

- **Thumbnail Image Clarity:** Drag the slider to adjust the clarity of the snapshots captured by face detection events.

Detection Parameters

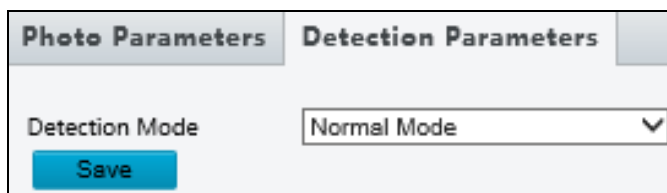

Figure 4-45

- **Detection Mode:** You can choose between **Normal Mode**, which detects for moving targets continuously, and **Filter Repeat Motion Mode**, which ignores repeated motions.

Click **Save** to keep the changes made.

4.7 Events

You can set the camera to generate an alarm upon motion detection, temperature alarm, audio alarm, and input trigger.

4.7.1 Motion Detection

Motion detection is used to generate an alarm whenever movement occurs in the specified area.

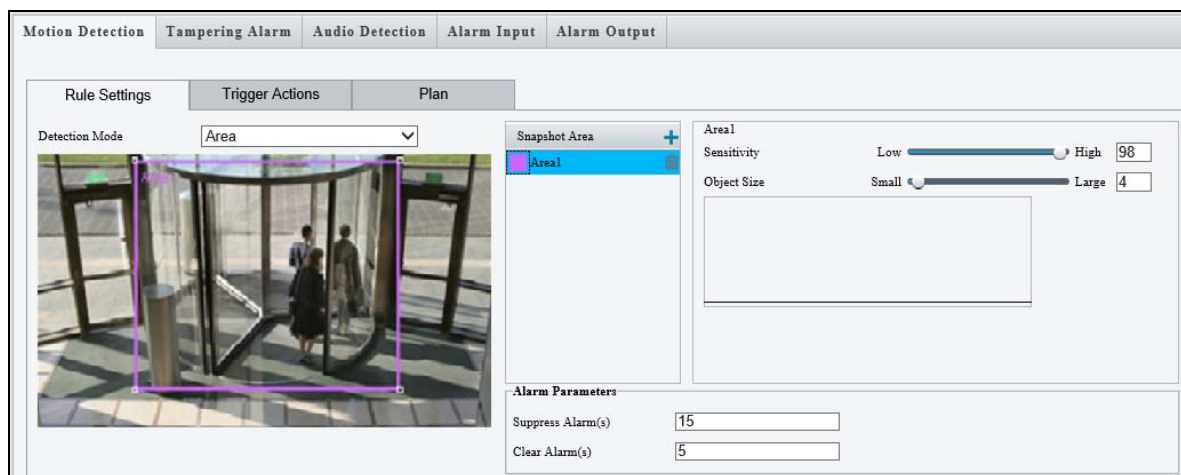



Figure 4-46

1. In the **Detection Area**, click  to create a new detection area.
2. Click and drag the detection area to a desired location.
3. Alternatively, select **Grid** as the **Detection Mode** to define the area for detection.
4. You can use the following functions to reduce false alarm.
5. You can use the following functions to reduce false alarm.
 - ⊙ **Sensitivity:** Move the slider to adjust the detection sensitivity.
 - ⊙ **Object Size:** When the extent of motion within the detection area exceeds the set object size, motion detection alarm is triggered.

[Alarm Parameters]

- **Suppress alarm:** After an alarm is triggered, the same alarm will not be reported within the set time.

- **Clear alarm:** After an alarm is triggered,
 - If the same alarm is not triggered within the set time, the alarm will be cleared and the same alarm can be reported again.
 - If the same alarm is triggered within the set time, the alarm will not be cleared until the suppress alarm time expires. Then the same alarm can be reported again.
6. For **Trigger Actions** and **Plan**, follow *Step 5 ~ 6, 3.5.1.1 Cross Line*.

Note:

1. For the **Upload to FTP** function, make sure to configure the settings in *4.8.3 FTP* and *4.3.3 Snapshot* first.
 2. For the **Trigger e-mail** function, make sure to configure the settings in *4.2.6 E-mail* and *4.3.3 Snapshot* first.
 3. For the **Trigger storage** function, make sure to configure the settings in *4.8.1 Storage*.
-

4.7.2 Tampering Alarm

Note this function is only applicable to **GV-SD2722-IR / 3732-IR**.

Tampering alarm is used to detect when the camera is being physically tampered with. An alarm can be generated when the camera is moved, covered up, or out of focus.

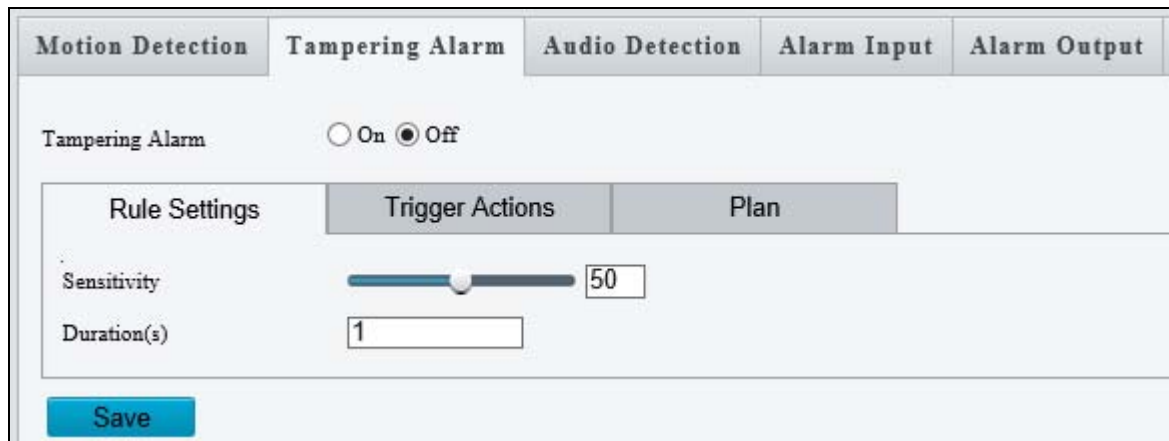

Figure 4-47

1. Select **On** to enable **Tampering Alarm**.
2. You can use the following functions to adjust the alarm settings.
 - ⊙ **Sensitivity**: Move the slider to increase or decrease detection sensitivity.
 - ⊙ **Duration**: Specify the duration of the alarm after which the triggered output device will be turned off.
3. For **Trigger Actions** and **Plan**, follow *Step 5 ~ 6, 4.6.2 Cross Line*.

4.7.3 Audio Detection

The camera can detect for abnormal audio volume. When the rise or fall of volume exceeds the set limit, or when the input volume reaches the threshold, the camera reports an alarm and triggers the set actions. Make sure an audio input device is correctly connected to the camera and audio input is enabled.

Note: To add an audio input, see [4.7.5 Alarm Input](#).

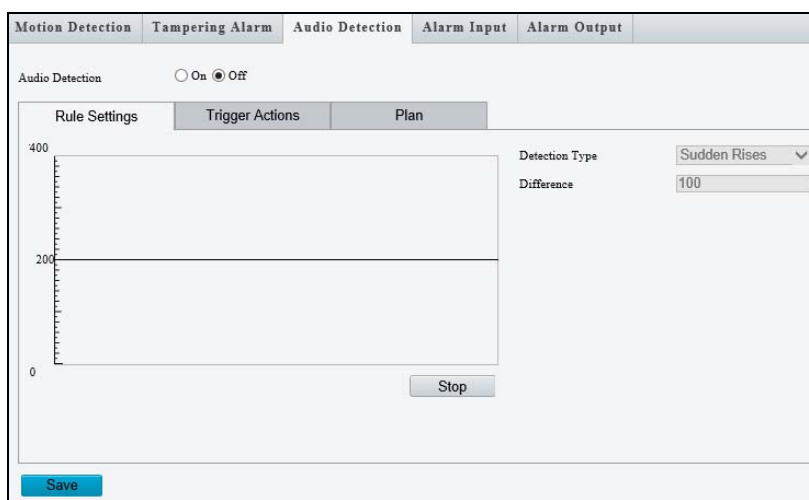

Figure 4-48

1. Select **Enable** to activate **Audio Detection**.
2. Select a **Detection Type**.
 - **Sudden Rise:** An alarm is reported when the rise of volume exceeds the difference.
 - **Sudden Fall:** An alarm is reported when the fall of volume exceeds the difference.
 - **Sudden Change:** An alarm is reported when the rise or fall of volume exceeds the difference.
 - **Threshold:** An alarm is reported when the volume exceeds a threshold.
3. Set a **Threshold** or **Difference**.
 - **Threshold:** After a volume is set as the threshold, an alarm is reported when the threshold is exceeded.
 - **Difference:** the difference between two volumes. When the rise or fall of volume exceeds the difference, an alarm is reported.

4. For **Trigger Actions** and **Plan**, follow *Step 5 ~ 6, 4.6.2 Cross Line*.

4.7.4 Alarm Input

The camera can receive alarm information from an input device.

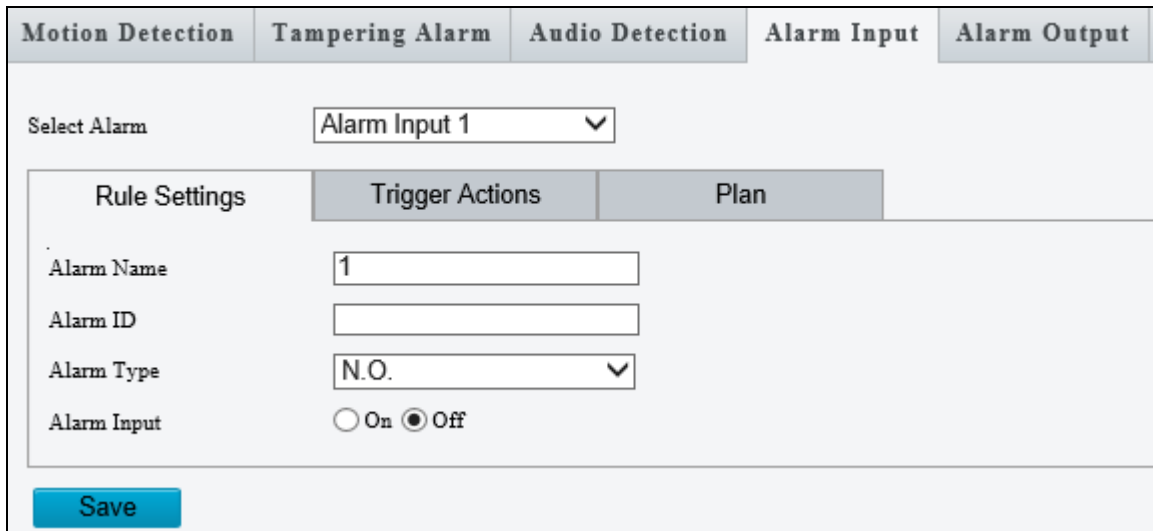

Figure 4-49

1. Select **Alarm Input 1** or **Alarm Input 2** from the drop-down list.
2. Type an **Alarm Name**, and set an **alarm ID**.
3. Select **Normally Open / N.O** or **Normally Closed / N.C** according to the type of the alarm input device.
4. Select **ON** next to Alarm Input.
5. For **Trigger Actions** and **Plan**, follow *Step 5 ~ 6, 4.6.2 Cross Line*.
6. Click **Save**.

4.7.5 Alarm Output

After alarm output is triggered by a motion detection alarm, temperature alarm or input alarm, the camera can trigger an output device.

Motion Detection	Tampering Alarm	Audio Detection	Alarm Input	Alarm Output
Select Alarm <input type="text" value="A → 1"/>				
Rule Settings		Output Schedule		
Alarm Name	<input type="text" value="2"/>			
Default Status	<input type="text" value="N.O."/> ▼			
Delay(s)	<input type="text" value="30"/>			
Relay Mode	<input type="text" value="Monostable"/> ▼			
<input type="button" value="Save"/>				

Figure 4-50

1. Type and **Alarm Name** for the output device.
2. Set the status to **Normally Open** (default setting).
3. Set the alarm duration.
4. Set relay mode to trigger the output device as alarm lights. Select **Monostable** to trigger by pulse or **Bistable** by low or high level.
5. Set a schedule plan in Output Schedule by following *Step 6, 4.6.2 Cross Line*.
6. Click **Save**.

4.7.6 Capture

Note this function is only for **GV-SD2322-IR**.

Using the Capture function, when an alarm is triggered, the camera will automatically upload the captured snapshots to the FTP server or send snapshots to the specified email address. For more detailed instructions, refer to *4.3.3 Snapshot* under *Video & Audio*.

4.7.7 Temperature Alarm

Note this function is only for **GV-SD2322-IR**.

You can set the camera to trigger the alarm output or move to a preset point when the camera temperature exceeds the maximum temperature or falls below the minimum temperature.

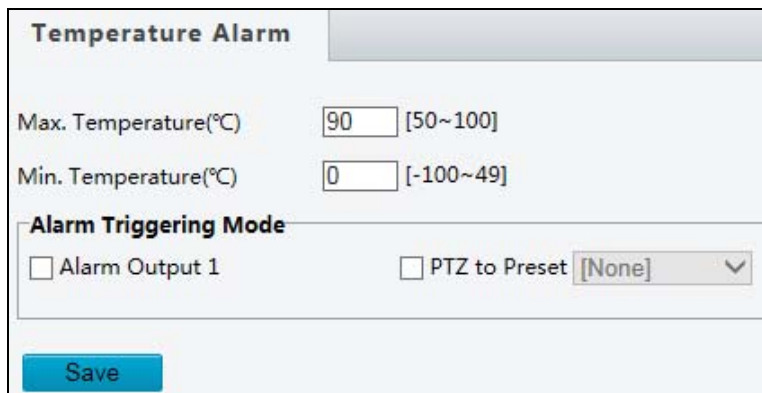

The image shows a configuration window titled "Temperature Alarm". It contains the following fields and options:

- Max. Temperature(°C)**: A text input field containing "90" with a range indicator "[50~100]" to its right.
- Min. Temperature(°C)**: A text input field containing "0" with a range indicator "[-100~49]" to its right.
- Alarm Triggering Mode**: A section containing two options:
 - Alarm Output 1
 - PTZ to Preset [None] (with a dropdown arrow)
- Save**: A blue button at the bottom left of the window.

Figure 4-51

4.8 Storage

This section allows you to configure memory card settings and download recorded videos.

4.8.1 Storage

After inserting a memory card, you need to reboot the camera and refresh the Web interface. You can configure the storage settings on the Storage page.

[Storage]

Storage

Storage Medium: Memory Card Enable

Storage Medium Status: Normal

Total Capacity 60890 MB, Free Space 0 MB.

Figure 4-52

- **Storage Medium:** Click the **Format** button to format the memory card before you start recording and **Enable** the memory card.

[Allocate Capacity]

Allocate Capacity

Video(MB) (The remaining capacity is used for image storage.)

Common Snapshot(MB) (The remaining capacity is used for Face snapshot storage.)

Face Snapshot(MB)

Figure 4-53

- **Video:** Set the storage capacity used to store recorded videos. The remaining capacity is used for captured snapshots.
- **Common Snapshot:** The storage capacity used to store captured snapshots.
- **Face Snapshot:** The storage capacity used to store captured face snapshots.

[Video Storage Info]

Video Storage Info

Storage Policy: Manual and Alarm Recording Scheduled and Alarm Recording Alarm Recording Only

Stream: Main Stream

When Storage Full: Overwrite Stop

Post-Record(s):

Figure 4-54

- **Storage Policy:** Choose the Storage Policy from the three options.
 - ⊙ **Manual and Alarm Recording:** Manually start recording and upon input-triggered events.
 - ⊙ **Scheduled and Alarm Recording:** Start recording by schedule and upon input-triggered events.
 - ⊙ **Alarm Recording Only:** Start recording upon input-triggered events.

Note: The file size of more than 500 MB is required to create one recording file.

- **Stream:** Select the stream you want to use for recording.
- **When Storage Full:**
 - ⊙ **Overwrite:** If there is no free space in the memory card, new data will overwrite the existing data repeatedly.
 - ⊙ **Stop:** If there is no free space in the memory card, new data will not be saved to the memory card.
- **Post Record(s):** When an alarm is raised, the camera is triggered to record live video and continues recording for the specified post-record time after the alarm is cleared.

4.8.2 Recording Download

You can search and download the recorded videos stored in the memory card.

1. Select a time period to search for video, and click **Search**. The search results are shown.

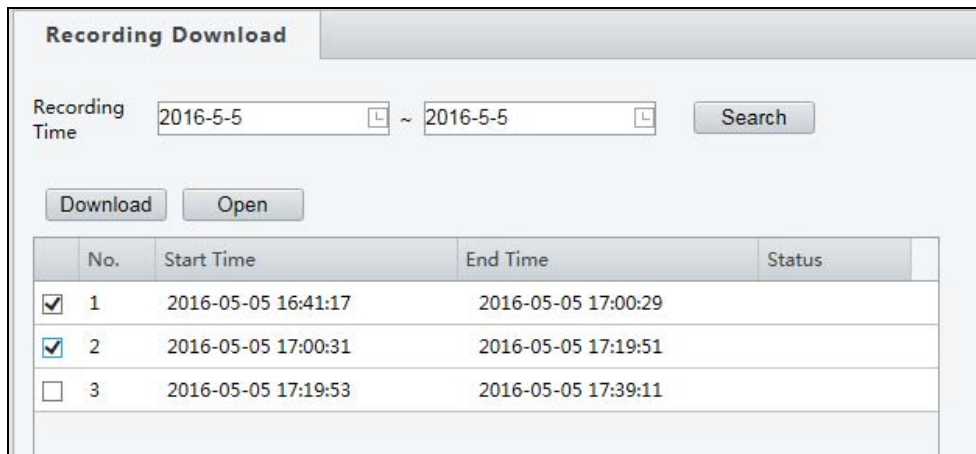

The screenshot shows a web interface titled "Recording Download". It features a search form with two date input fields set to "2016-5-5" and a "Search" button. Below the search form are "Download" and "Open" buttons. A table displays the search results with columns for "No.", "Start Time", "End Time", and "Status". Three rows are visible, with the first two rows having their "No." checkboxes checked.

No.	Start Time	End Time	Status
<input checked="" type="checkbox"/> 1	2016-05-05 16:41:17	2016-05-05 17:00:29	
<input checked="" type="checkbox"/> 2	2016-05-05 17:00:31	2016-05-05 17:19:51	
<input type="checkbox"/> 3	2016-05-05 17:19:53	2016-05-05 17:39:11	

Figure 4-55

2. To download the videos, select the files and click **Download**.
3. To open the folder for storing recordings, click **Open**.

Note: Currently, the downloaded files will not include audio data. Audio data for recordings downloaded will be supported in future firmware versions.

4.8.3 FTP

After the configuration of FTP, you will be able to upload snapshots from the camera to the specified FTP server.

General

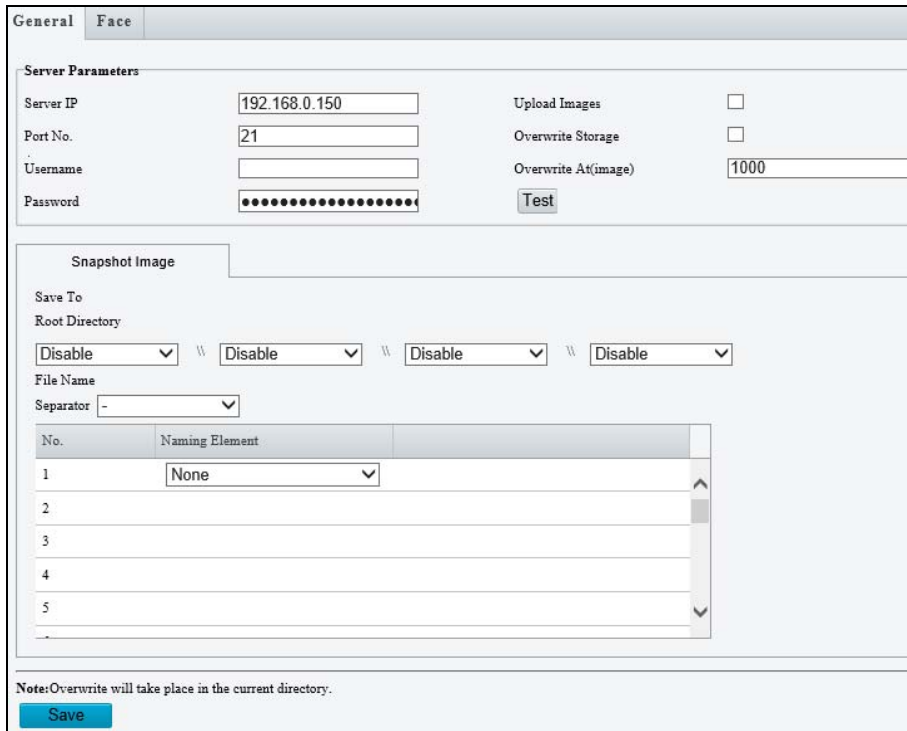

The screenshot shows a configuration window with two tabs: 'General' and 'Face'. The 'General' tab is active. It is divided into two main sections: 'Server Parameters' and 'Snapshot Image'.

Server Parameters:

- Server IP: 192.168.0.150
- Port No.: 21
- Username: [Empty]
- Password: [Masked with dots]
- Upload Images:
- Overwrite Storage:
- Overwrite At(image): 1000
- Test: [Button]

Snapshot Image:

Save To

Root Directory: [Disable] \ [Disable] \ [Disable] \ [Disable]

File Name

Separator: [Dropdown]

No.	Naming Element
1	[None]
2	
3	
4	
5	

Note: Overwrite will take place in the current directory.

[Save]

Figure 4-56

1. Type the **Server IP** address.
2. Change the **Port No.** of the FTP server if needed.
3. Type the **Username** and **Password** of the upload account.
4. Enable **Upload Pictures / Upload Images**.

Step 5, 6 and 7 are applicable only to **GV-SD2722-IR / SD3732-IR**:

5. select **Overwrite Storage** to overwrite the oldest images when the storage is full. You can set the number of images in **Overwrite At (Image)**. When the defined image threshold is reached, the oldest images will be overwritten.
6. **Save To Root Directory**: Select a directory in which to save the images, or select **Custom** to name a storage folder on the FTP server.
7. Under **File Name**, select a **Separator** and a combination of **Naming Element(s)** to name the snapshots captured. A template of the file name is shown.

8. Click **Save**.

Note:

1. To upload snapshots, make sure to enable **Snapshot** in Video & Audio. For more detailed instructions, refer to *4.3.3 Snapshot*.
 2. If **Overwrite Storage** is not selected and the storage is full, snapshots can no longer be taken.
-

Face

This function is used to store snapshots taken for smart functions such as face detection.

Figure 4-57

1. Type the **Server IP** address.
2. Change the **Port No.** of the FTP server if needed.
3. Type the **Username** and **Password** of the upload account.
4. **Save To Root Directory:** Select a directory in which to save the images, or select **Custom** to name a storage folder on the FTP server.
5. Under **File Name**, select a **Separator** and a combination of **Naming Element(s)** to name the snapshots captured. A template of the file name is shown.

4.8.4 Backing Up Storage

Note this function is only applicable to Internet Explorer browsers.

In the Photo setting, you can back up the existing videos and snapshots to your local PC.

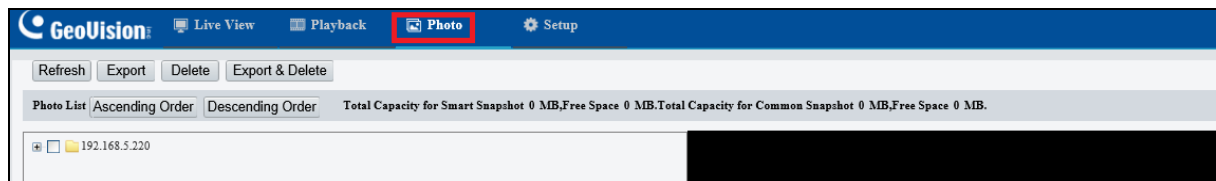



Figure 4-58

1. Select **Photo** at the top of the Web interface and click **Refresh**.
2. Click **Ascending Order** or **Descending Order** to sort the folders.
3. Click  to view more folders and select or deselect the folders to back up.
4. Click **Export** and select a destination to store the selected folders.

Click **Delete** to delete the selected folders.

4.9 Security

Note these functions are only for **GV-SD2722-IR / SD3732-IR**.

This section allows you to create user accounts and set the network security settings.

4.9.1 User

There are two types of accounts: **Administrator** and **Common User**. For more detailed instructions, refer to *4.10.3 Security*.

4.9.2 Network Security

There are four of network security settings: **HTTPS**, **RTSP Authentication**, **ARP Binding** and **IP Address Filtering**.

For **HTTPS** and **RTSP Authentication**, refer to *4.10.3 Security*.

ARP Binding / ARP Protection

This function can protect the camera from ARP attacks. When the camera visits an IP of another network segment via a gateway, it can only communicate with the MAC address binding to the gateway address in the same segment.

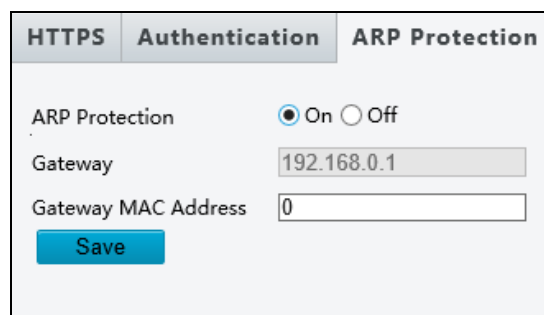

HTTPS	Authentication	ARP Protection
		ARP Protection <input checked="" type="radio"/> On <input type="radio"/> Off
		Gateway <input type="text" value="192.168.0.1"/>
		Gateway MAC Address <input type="text" value="0"/>
		<input type="button" value="Save"/>

Figure 4-59

1. Enable **ARP Binding**.
2. Type **MAC Address**.
3. Click **Save**.

IP Address Filtering

You can allow or deny the access from the specified IP address to your camera.

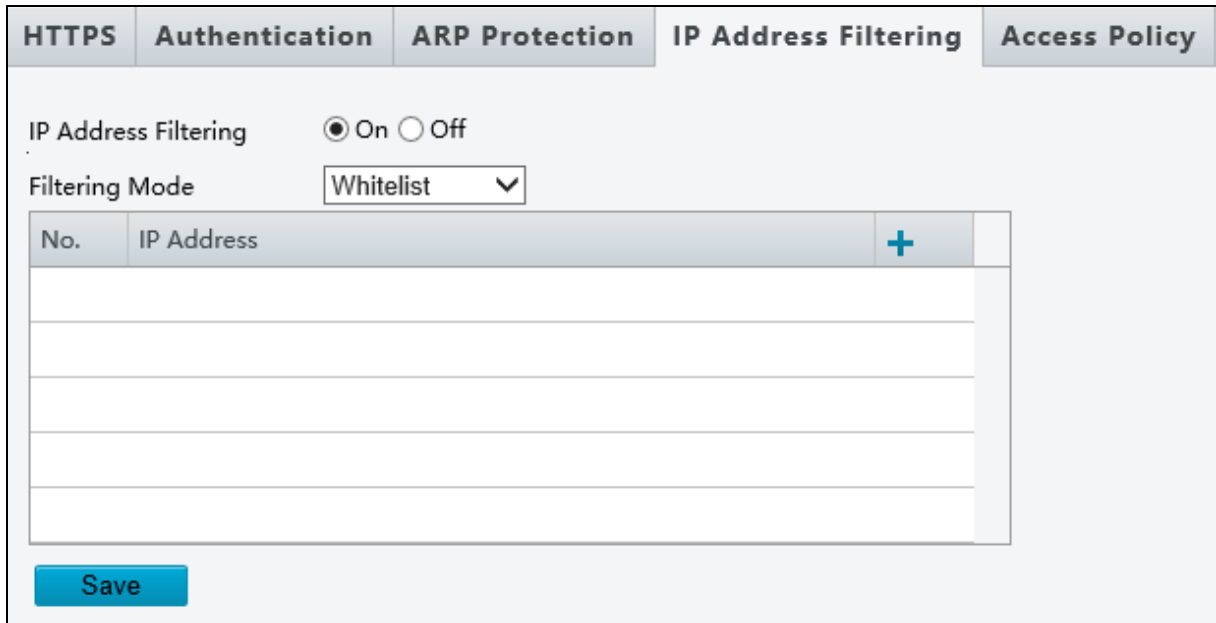

IP Address Filtering On Off

Filtering Mode Whitelist ▾

No.	IP Address	+

Save

Figure 4-60

1. **Enable** IP Address Filtering.
2. Choose a Filtering Mode: **Allow Access / Whitelist** or **Deny Access**.
3. Click **+** to add an IP address.
4. Click **Save**.

Access Policy

Note this function is applicable only to **GV-SD2722-IR / SD3732-IR**.

You can login with a weaker password by adjusting the password strength. When this option is disabled, the camera prompts you to set up a stronger password if you attempt to login with a weaker password.

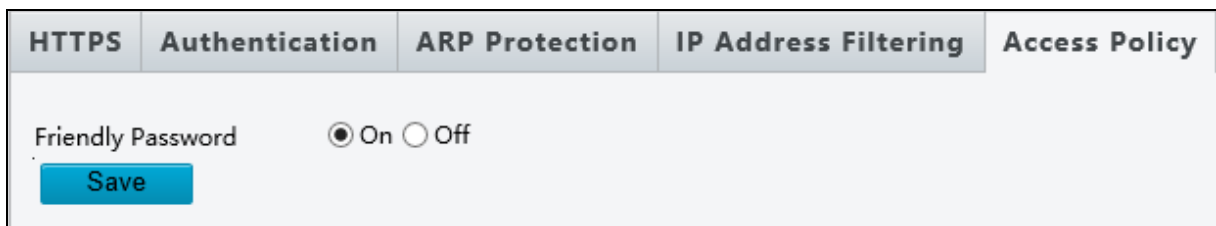

Friendly Password On Off

Save

Figure 4-61

4.10 System

This section allows you to create user accounts, set the camera time, and update the firmware.

4.10.1 Time

You can use the following methods to adjust the system time of your camera.

Figure 4-62

To manually set a time or synchronize with the computer time:

1. Enable **Time Sync** (For **GV-SD2322-IR** Only)
2. Select a **Sync Mode**.
 - ⊙ **Sync with System Configuration**: Select a Time Zone, manually set a time by clicking on the System Time, or synchronize with the computer time.
 - ⊙ **Sync with NTP Server**: To synchronize with a network time server, type the IP address of the network time server next to **NTP Server Address** and specify the Update Interval.
 - ⊙ **Sync with Management Server (ONVIF)**: The device time is synchronized with Management Server (ONVIF).
 - ⊙ **Sync with Latest Server Time**: The device time is synchronized with the latest updated time, either on ONVIF or the Web interface.
3. Select a **Time Zone**.
4. Next to System Time, manually set the camera's time or click **Sync with Computer Time** to synchronize with the time of your PC.
5. Click **Save**.

To synchronize with a network time server (For **GV-SD2722-IR / SD3732-IR** only):

1. Enable **NTP**.
2. Type the IP address of the network time server next to **NTP Server IP**.
3. Click **Save**.

4.10.2 DST

To adjust the camera's time for daylight saving time:

1. Click the **DST** tab at the top.

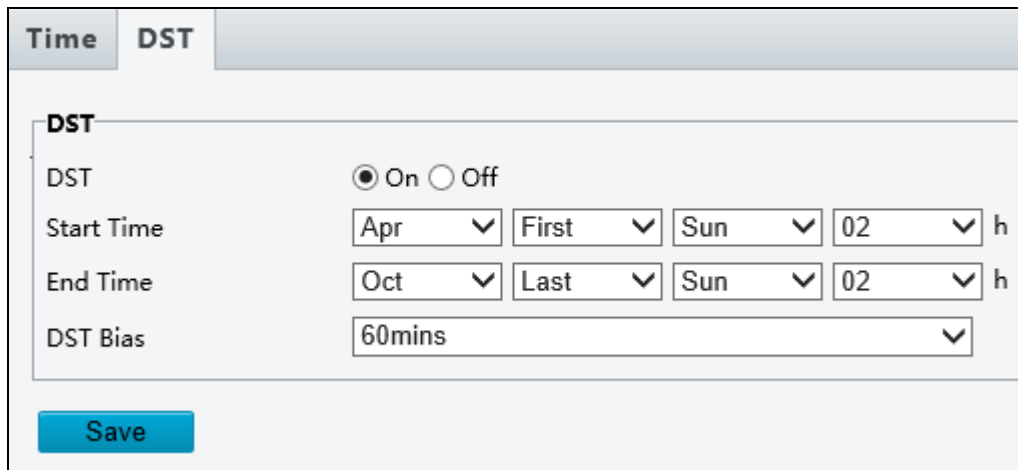

The screenshot shows a web interface with two tabs: 'Time' and 'DST'. The 'DST' tab is selected. Below the tabs, there is a section titled 'DST' with the following controls:

- A radio button labeled 'On' is selected, and an 'Off' radio button is unselected.
- 'Start Time' is configured with dropdowns for 'Apr', 'First', 'Sun', and '02', followed by a unit dropdown set to 'h'.
- 'End Time' is configured with dropdowns for 'Oct', 'Last', 'Sun', and '02', followed by a unit dropdown set to 'h'.
- 'DST Bias' is set to '60mins' in a dropdown menu.
- A blue 'Save' button is located at the bottom left of the form.

Figure 4-63

2. Select **Enable DST / ON**.
3. Set a **Start Time** and **End Time** for the daylight saving time.
4. Select a time period for **DST Bias**.
5. Click **Save**.

4.10.3 Maintenance

This section allows you to upgrade firmware, restart the camera, and backup/import camera configurations.

The screenshot shows the 'Maintenance' web interface with the following sections:

- Software Upgrade:** Includes a 'Local Upgrade' text input field, 'Browse...' and 'Upgrade' buttons, and an unchecked checkbox for 'Upgrade Boot Program'. A note states: 'Note: The upgrade will take a while. Please do not disconnect power.'
- Config Management:** Features a 'Default' button, a checkbox for 'Restore all settings to defaults without keeping current network and user settings.', 'Importing' and 'Exporting' text input fields, and 'Browse...', 'Import', and 'Export' buttons.
- Diagnosis Info:** Includes an 'Export Diagnosis Info' text input field, 'Browse...' and 'Export' buttons, and a checked checkbox for 'Collect Image Debugging Info'.
- Mounting Info:** Has a 'Mounting Height (cm)' text input field with the value '600' and an 'OK' button.
- Focus:** Contains 'Min. Focus Distance(cm)' and 'Max. Zoom Ratio' dropdown menus with values '10' and '33' respectively, each with an 'OK' button.
- Device Restart:** Includes a 'Restart' button and the text 'Restart device'.

Note: 1. Software upgrade, device restart, restoration to defaults, configuration import, or changing the minimum focus distance will restart the device.
2. Restarting the device will interrupt the connection to the device.

Figure 4-64

[Firmware Upgrade / Software Upgrade].

For detailed instructions, refer to *6.1 Upgrading System Firmware* and *6.1.1 Using the Web Interface*.

[Config Management] Export the current configurations of the camera and save them to the PC or an external storage medium. You can also quickly restore configurations by importing backup configurations stored on the PC or an external storage medium back to the camera.

[Diagnosis Info] Includes logs and system configurations. You can export diagnostic information to your PC. Click **Browse** to select the destination folder, and then click **Download** to save the diagnostic information to the specified folder.

[Mounting Info] Type the actual height from the installed infrared dome to the ground, so that the camera will be able to automatically adjust its infrared lamp.

[Focus] The device can adjust the speed of auto-focus according to the **minimum focus distance**. It is recommended that the minimum focus distance is set shorter than the distance between the objects and lens. For example, if the minimum focus distance is 3 m, then the objects within 3 m from lens will be out of focus. For **GV-SD2722-IR / SD3732-IR**, you can adjust zoom ratio to see the clear image when zooming in according to the **maximum zoom ratio**.

Focus	
Min. Focus Distance(cm)	<input type="text" value="10"/> <input type="button" value="OK"/>
Max. Zoom Ratio	<input type="text" value="33"/> <input type="button" value="OK"/>

Figure 4-65

[Device Restart] Click **Restart** to restart the device after you confirm the operation.

4.10.4 Security

Three tabs are available under the Security page: User, HTTPS, and RTSP Authentication.

User

There are two types of accounts: **Administrator** and **Common User**.

- **Administrator:** The default name of the administrator is admin, which cannot be modified. Admin has full permission and can manage all users and devices. Only one admin account is allowed in the system.
- **Common Users:** User only has permission to play live and recorded video. Up to 31 common users are allowed in the system.

The administrator can create new account for a common user. After the user is added successfully, the administrator can change the password by entering the new password or delete the user by clearing the username.

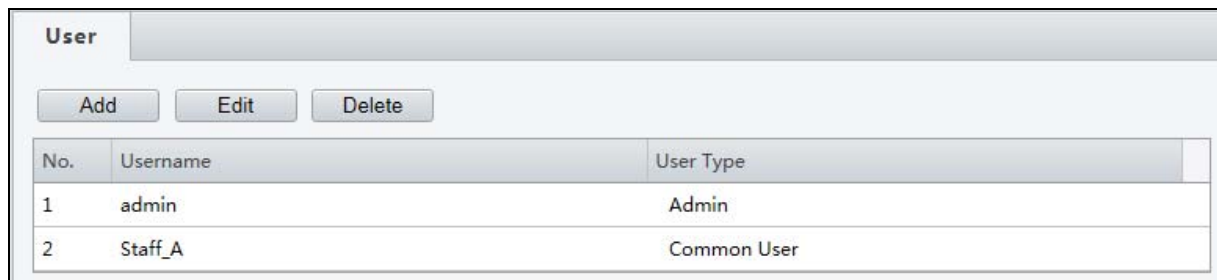

No.	Username	User Type
1	admin	Admin
2	Staff_A	Common User

Figure 4-66

Note: Changing the username or password for a user when the user is still logged in will force the user to log out. The user must use the new username or password to log in.

HTTPS

You can enable the Hypertext Transfer Protocol Secure (HTTPS) settings to access the camera through a secure protocol. Click **Enable** and click **Save**.



Enable

Save

Figure 4-67

RTSP Authentication

RTSP (Real Time Streaming Protocol) is an application layer protocol for transmitting audio and video. Set the authentication mode for RTSP streaming.



The image shows a configuration window with three tabs: "User", "HTTPS", and "RTSP Authentication". The "RTSP Authentication" tab is selected. Inside this tab, there is a label "Authentication" next to a dropdown menu that currently displays "digest". Below the dropdown menu is a blue "Save" button.

Figure 4-68

4.10.4 Ports and Device

Note this function is only applicable to **GV-SD2722-IR / SD3732-IR**.

Use the RS485 serial port to transmit data to the third-party device.

The screenshot shows a configuration window titled "Serial Port" with a sub-section for "RS485_1". The settings are as follows:

Parameter	Value
Port Mode	Trans-Channel
Baud Rate	9600
Data Bits	8
Stop Bits	1
Parity	None
Flow Control	None

Below the settings is a checkbox labeled "Enable Trans-Channel" which is currently unchecked. A blue "Save" button is located at the bottom left of the window.

Figure 4-69

1. Select **Trans-Channel / OSD / Local PTZ Control / Trans-Channel via ONVIF** from the **Port Mode** drop-down list.
 - **Transparent Channel (Trans-Channel) / Transparent Channel (via ONVIF):**
Achieve transparent data transmission between two devices by using RS485 serial port or ONVIF.
 - **OSD:** Display information from the third-party device on the OSD.
 - **Local PTZ Control:** Control a PTZ camera through a third-party device.
2. Select **Enable Trans-Channel** if **Trans-Channel** is selected.
3. Click **Save**.

Note:

1. If the **OSD** port mode is selected, the camera receives information from the third-party device through the RS485 serial port, translates the received information, and then displays it on the OSD.
 2. If the **Local PTZ Control** port mode is selected, by sending PELCO-D compliant PTZ control commands through the RS485 port, you can control the PTZ camera without using the PTZ control panel.
-

Chapter 5 Recording and Playback

The camera can record video and audio directly to the memory card.

Note: See *Note for Recording* at the beginning of the manual.

5.1 Recording

To configure the recording function, refer to the following sections

- Insert the memory card into the camera -- See *1.6 Installation*.
- Format the memory card, create a recording schedule, set up post-recording or select the stream for recording -- See *4.8.1 Storage*.
- Set up recording upon motion detection -- See *4.7.1 Motion Detection*.
- Set up recording upon audio detection -- See *4.7.3 Audio Detection*.
- Set up recording upon input trigger -- See *4.7.4 Alarm Input*.

5.2 Playback from the Memory Card

You can play back the files recorded at the memory card of the camera from the Web interface.

1. Click **Playback** at the top. This page appears.

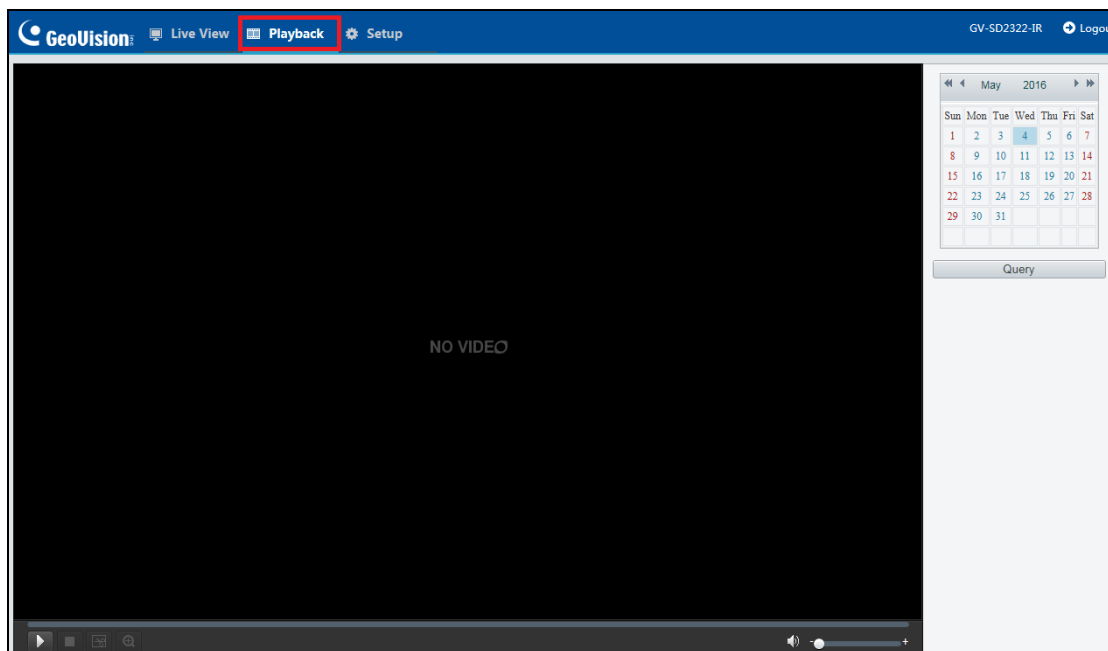

Figure 5-1

2. On the right, select a date and click **Query**.



Figure 5-2

- Double-click a search result to play back the recorded file, or select the desired time on the Timeline at the bottom to play back the video from. You can also adjust the audio volume at the bottom-left corner if needed.

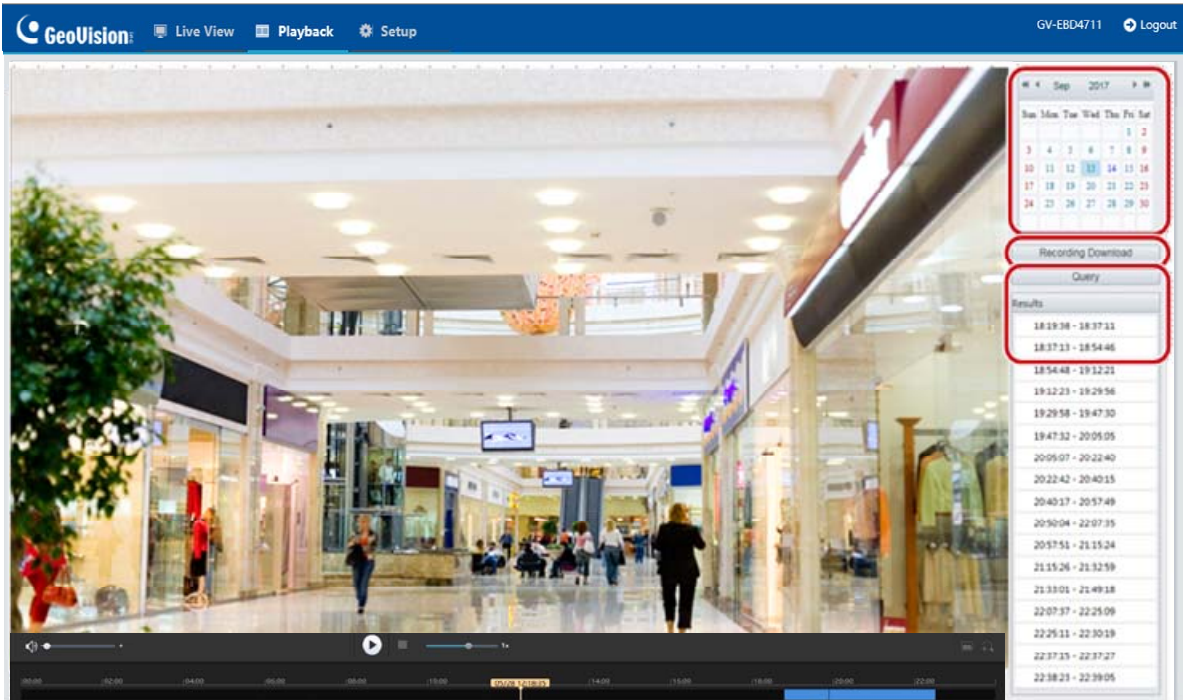



Figure 5-3

The following functions are available:

- **Snapshot** : Click to capture a snapshot of the recorded video.
- **Digital Zoom** : Click the icon and draw a box on the camera view to digitally zoom in.

Chapter 6 Advanced Applications

This chapter introduces more advanced applications.

6.1 Upgrading System Firmware

GeoVision periodically releases updated firmware on the company [website](#). The new firmware can be loaded into the camera using the Web interface or the **GV-IP Device Utility**.

Important Notes before You Start

Before you start updating the firmware, please read these important notes:

1. If you use the GV-IP Device Utility for firmware upgrade, the computer used to upgrade firmware must be under the same network of the camera.
2. Stop monitoring of the camera.
3. Stop the device's connection to GV-VMS / DVR / NVR and all remote connections.
4. While the firmware is being updated, the power supply must not be interrupted.

WARNING: The interruption of power supply during updating causes not only update failures but also damages to your camera. In this case, please contact your sales representative and send your device back to GeoVision for repair.

5. Do not turn the power off within 10 minutes after the firmware is updated.
6. If firmware upgrade fails, you will need to restore the camera to the default settings. For details, see *6.2 Restoring to Factory Default Settings*.

6.1.1 Using the Web Interface

Log into the Web interface and follow the steps below to update the firmware.

1. At the top, click **Setup**.
2. In the left menu, select **System** and select **Maintenance**. This page appears.

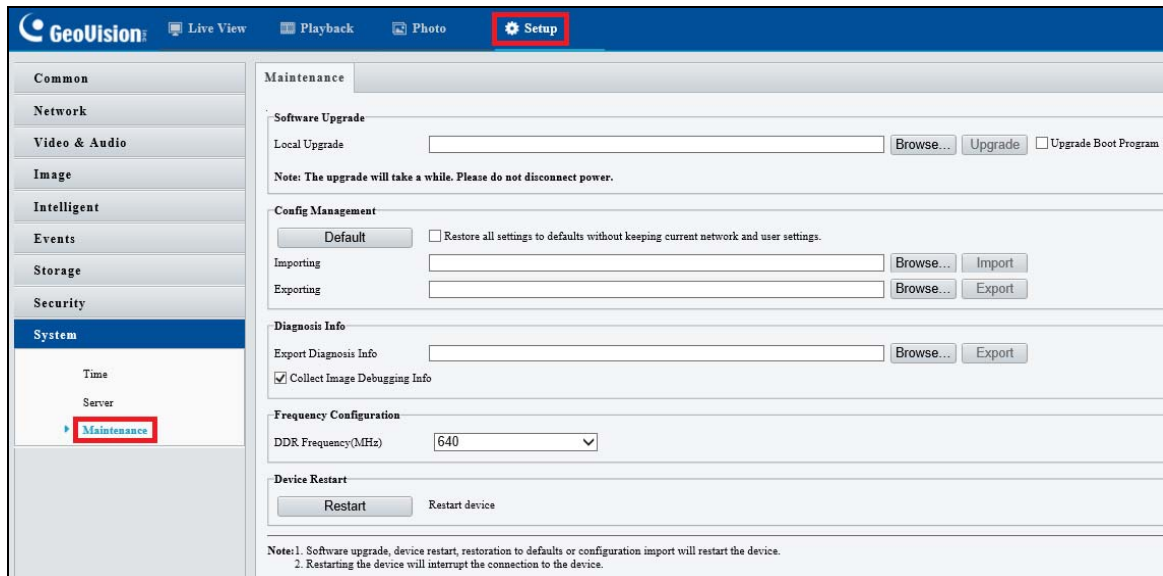

Figure 6-1

3. Click the **Browse** button to locate the firmware file (.zip) saved at your local computer.
4. Optionally select **Upgrade Boot Program** to reboot the camera after a successful upgrade.
5. Click the **Upgrade** button to process the upgrade.

6.1.2 Using the GV-IP Device Utility

You can upgrade the camera firmware using the GV-IP Device Utility. Note the computer used to upgrade firmware must be under the same network of the camera.

1. Download **GV-IP Device Utility** from the company [website](#). Then follow the onscreen instructions to install the program.
2. Double-click the **GV IP Device Utility** icon created on your desktop.
3. Click the camera in the list and select **Configure**.

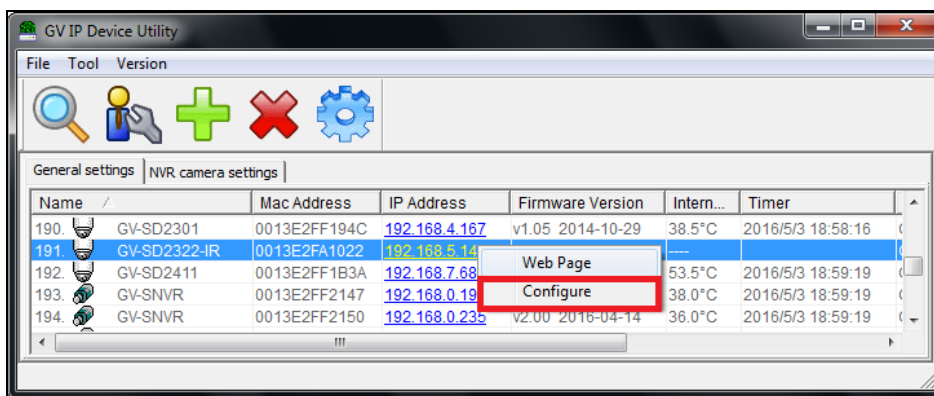

Figure 6-2

5. Type the camera's user name and password to login.
6. Click the **Firmware Upgrade** tab. This dialog box appears.

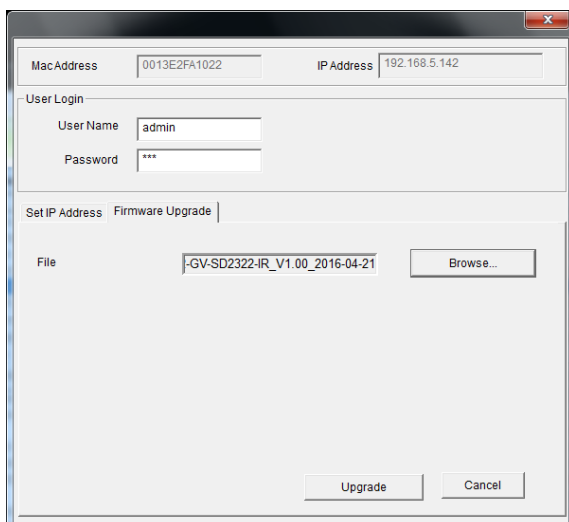

Figure 6-3

7. Click the **Browse** button to locate the firmware file (.zip) saved at your local computer.
8. Click **Upgrade** to start upgrading the firmware.

6.2 Restoring to Factory Default Settings

If for any reason the camera is not responding correctly, you can restore the camera back to its factory default settings using the Web interface or the **Default Button**.

6.2.1 Using the Web Interface

To restore to default settings using the Web interface:

1. At the top, click **Setup**.
2. In the left menu, select **System** and select **Maintenance**.
3. Under the **Config Management** section, click the **Default** button.

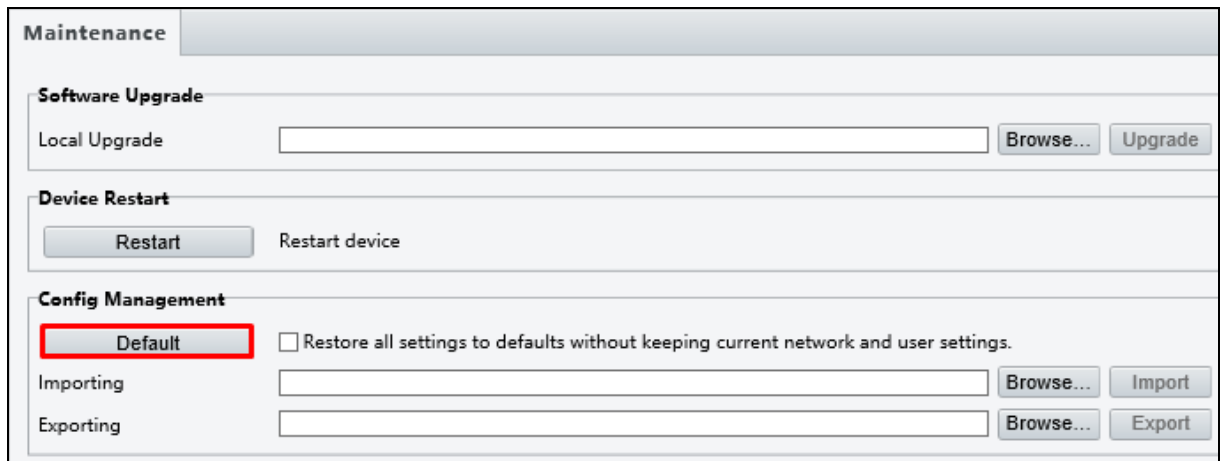

The screenshot shows the 'Maintenance' section of a web interface. It is divided into three main sections: 'Software Upgrade', 'Device Restart', and 'Config Management'. The 'Default' button in the 'Config Management' section is highlighted with a red rectangle. The 'Default' button is located to the left of a checkbox labeled 'Restore all settings to defaults without keeping current network and user settings.' Below the 'Default' button are two rows: 'Importing' and 'Exporting', each with a text input field and 'Browse...' and 'Import'/'Export' buttons.

Figure 6-4

6.2.2 Directly on the Camera

1. Unscrew the back cover of the camera.



Figure 6-5

2. Press and hold the **default** button for about 30 seconds.

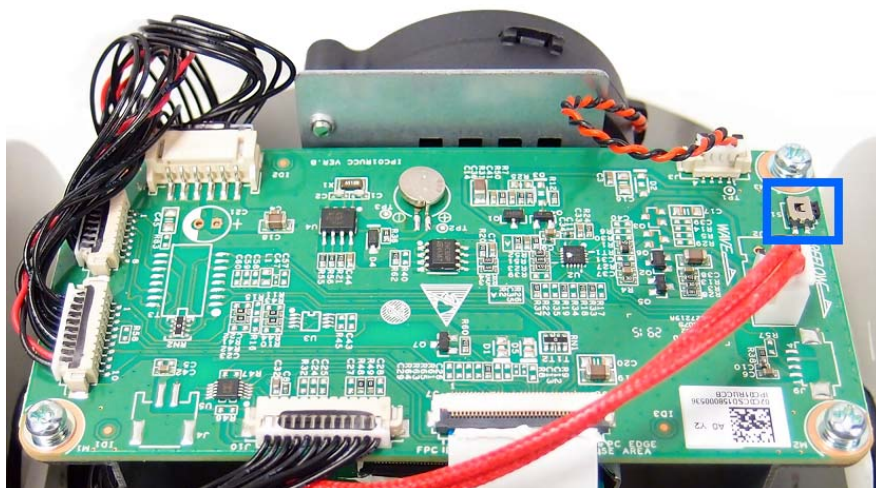

Figure 6-6

3. When the camera rotates twice, the process of loading default is completed and the camera robots automatically.

Chapter 7 VMS / DVR / NVR

Configurations

The GV-VMS / DVR / NVR provides a complete video management solution, including video viewing, recording, playback, alert settings, and more. The integration specifications are listed below:

- The compatible GV-VMS / DVR / NVR versions are listed below:

Camera Model	Compatible GV-DVR / NVR	Compatible GV-VMS
GV-SD2322-IR	V8.7.0.0 or later	V15.10.1.0 with patch files or later
GV-SD2722-IR	V8.7.4.0 with patch files or later	V17.1.0.100 or later
GV-SD3732-IR	V8.7.1.0 with patch files or later	V15.11.1.0 with patch files or later

- When connecting to other applications, an IP camera supports remote connections of up to 40 Mbps in throughput and a maximum of 20 streams.
- When a GV-IP Speed Dome is connected to IE browser or any other applications, it takes up 1 stream; when it is connected to GV-VMS / DVR / NVR, it takes up 2 streams.

7.1 Setting up IP Cameras on GV-DVR / NVR

To set up the camera on the GV- DVR / NVR, follow these steps:

1. On the main screen, click the **Configure** button, select **System Configure**, select **Camera Install** and click **IP Camera Install**. This dialog box appears.

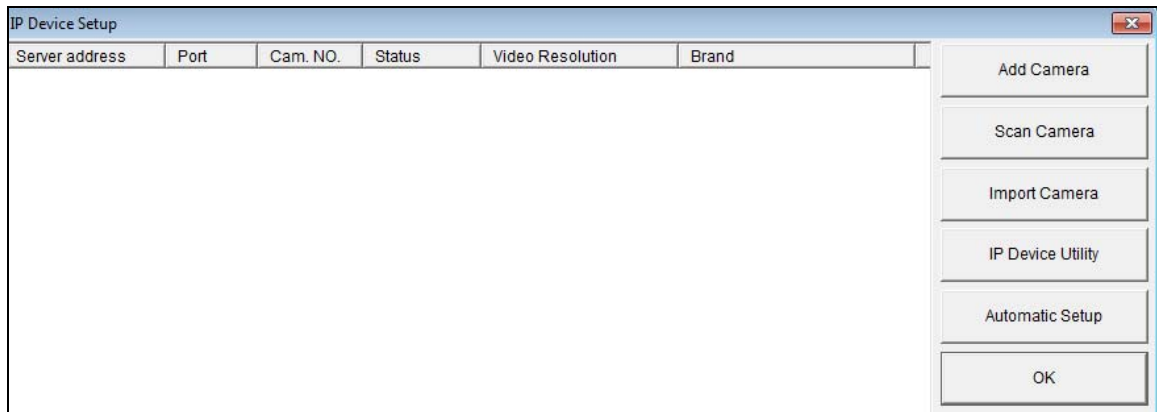

Figure 7-1

2. To automatically set up the camera, click **Scan Camera** to detect any camera on the LAN.
3. Double-click the camera and type the user name and password of the camera.

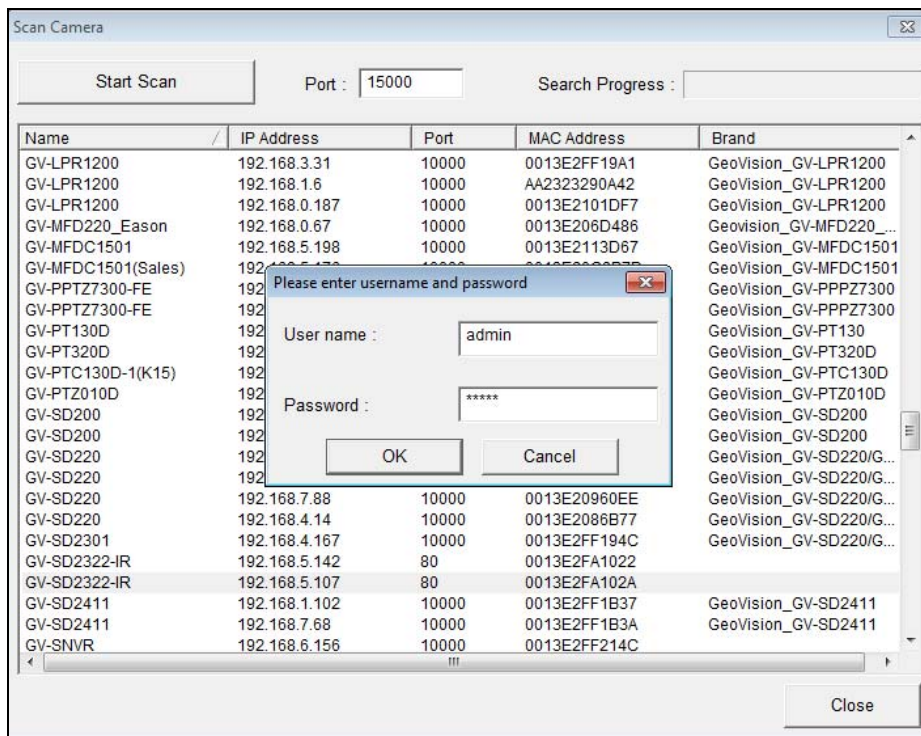

Figure 7-2

- Click **OK**. This dialog box appears.

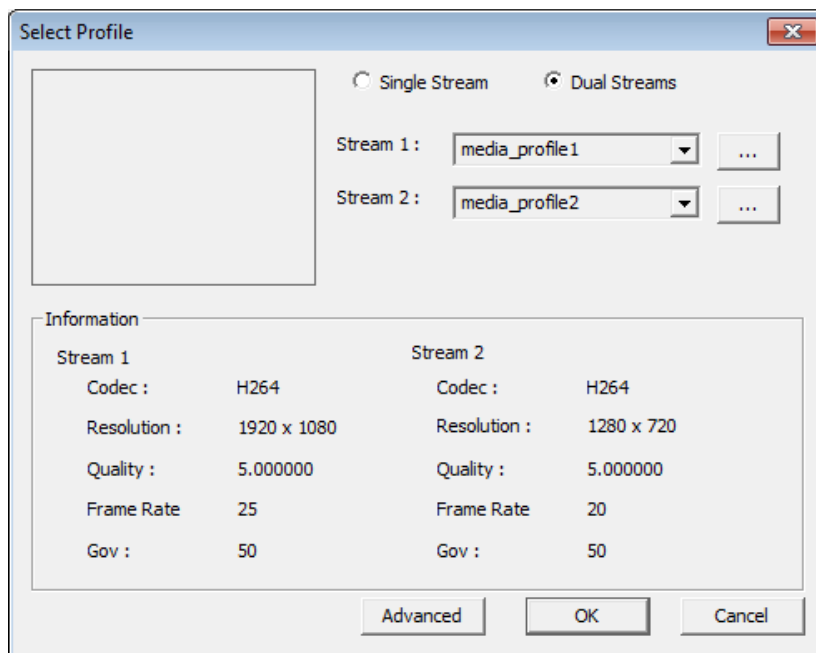

Figure 7-3

- Click **OK**. The camera is added to the connection list.
- Click the listed camera and select **Display position** to map the camera to a channel on the GV-DVR / NVR.

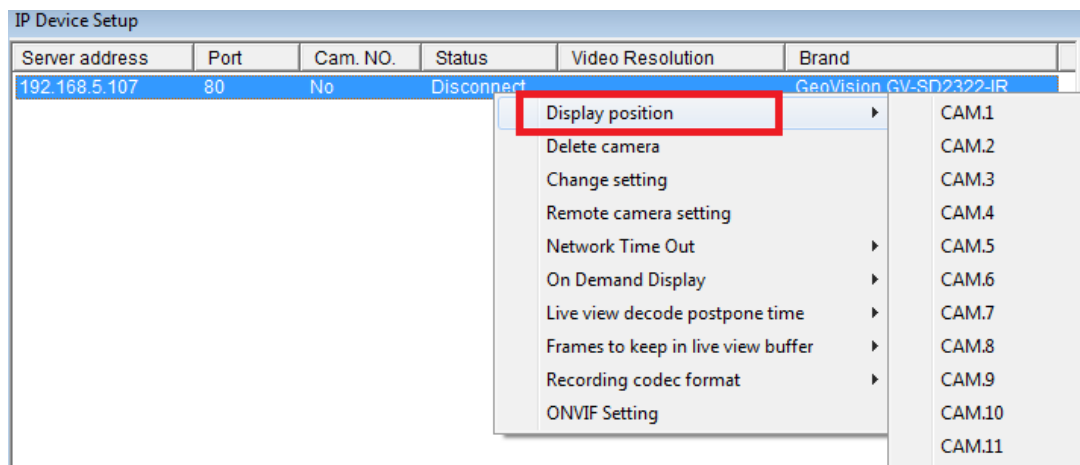

Figure 7-4

- The Status column should display "Connected". Click **OK**.

7.1.1 Customizing the Basic Settings on GV-DVR / NVR

After the camera is connected and assigned with a display position, you can configure the camera's settings such as frame rate, codec type and resolution. Right-click the desired camera to see the following list of options:

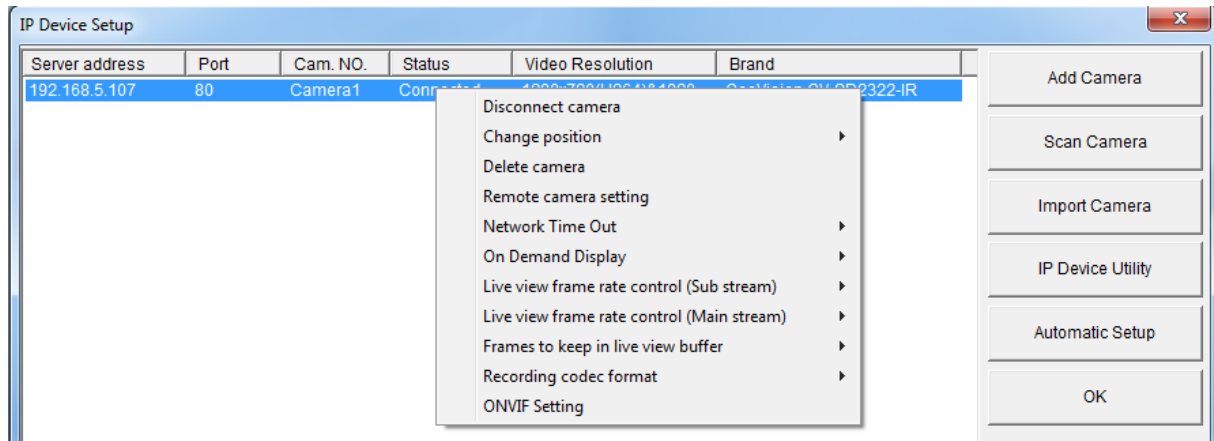





Figure 7-5

- **Network Time Out:** When network disconnection exceeds the specified time period, the camera status will be displayed as Connection Lost.
- **On-Demand Display:** Enables automatic switching between main stream and sub stream based on the size of camera image on screen.
- **Live-view frame rate control (Sub / Main):** Sets the frame rate of the stream to help reduce the CPU usage. If you have set the codec to be MJPEG, select the number of frames to allow in a second. If the codec selected is H.265 or H.264, select one of the following options:
 - ⊙ **Maximum Live-view Frame Rate:** View the video at the maximum frame rate possible.
 - ⊙ **Live-view Key Frame only:** You can choose to view the key frames of the videos only instead of all frames on the live view. This option is related to the GOP setting of the IP camera. For example, if the GOP value is set to 30, there is only one key frame among 30 frames.
- **Frames to keep in live view buffer:** Specifies the number of frames to keep in the live view buffer.
- **Recording Codec Format:** Select the codec to record in.

7.2 Setting Up IP Cameras on GV-VMS

Follow the steps below to manually connect your camera to GV-VMS.

1. To access the IP Device Setup page, click **Home** , select **Toolbar** , click **Configure**  and select **Camera Install**.

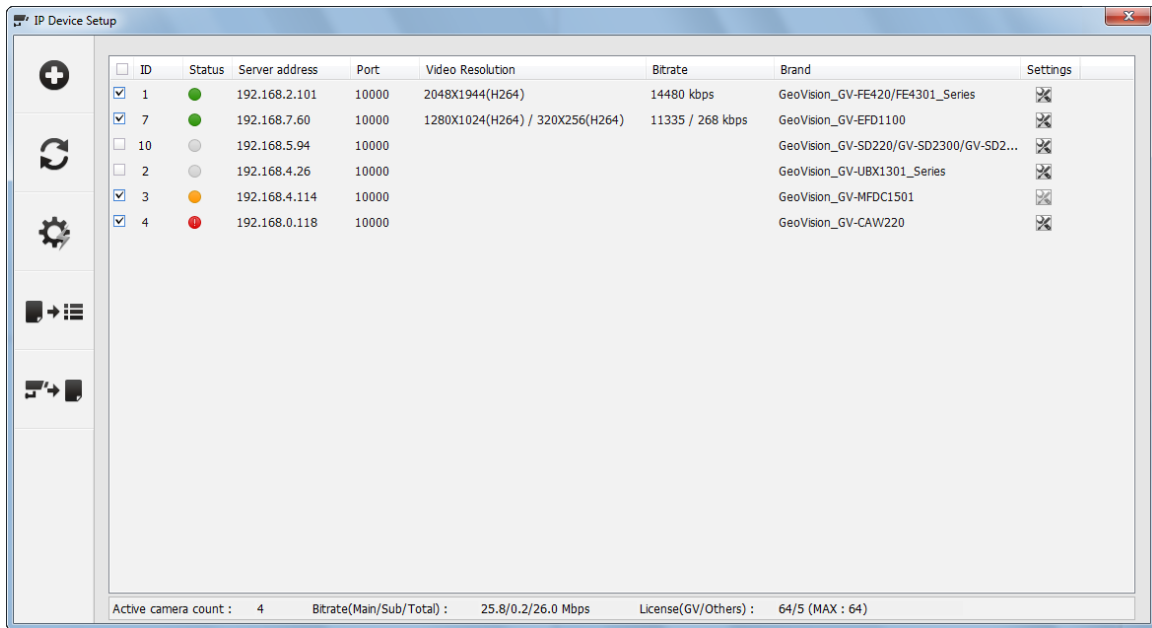



Figure 7-6

2. Click **Automatic Setup** .
3. Double-click the camera and type the user name and password of the camera.

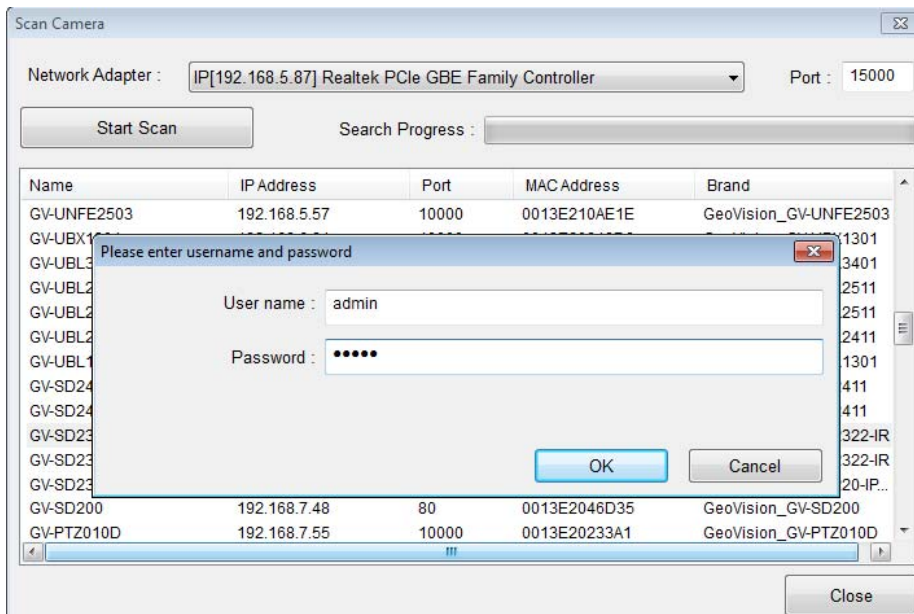

Figure 7-7

- Click **OK**. This dialog box appears.

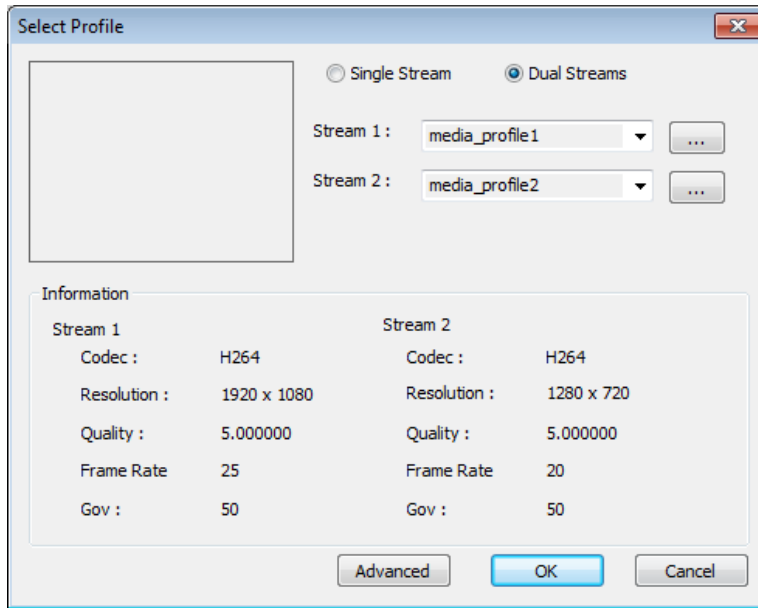

Figure 7-8

- Click **OK** to add the camera to the list.
- To connect the added camera, click the box beside the **ID** column. Upon successful connection, the **Status** icon shows green, with the video resolution and bit rate being displayed in the corresponding columns.

<input type="checkbox"/>	ID	Status	Server address	Port	Video Resolution	Bitrate	Brand	Settings
<input type="checkbox"/>	1	●	192.168.4.177	10000			GeoVision_GV-FER3402/3	⌵
<input checked="" type="checkbox"/>	2	●	192.168.5.142	80	1920X1080(H264) / 720X576(H...	3960 / 1000 kbps	GeoVision_2_GV-SD2322-IR(ONVIF)	⌵

Figure 7-9

Appendix

A. RTSP Multicast Protocol Support

The camera can support RTSP multicast protocol for both video and audio streaming.

You can use the following RTSP multicast command to access the camera image:

Stream 1:rtsp://<IP of the camera>/multicast/video1

Stream 2:rtsp://<IP of the camera>/multicast/video2

For example, rtsp://192.168.4.115/multicast/video1