

ACC650 Enclosure Installation Instructions

1 Overview

The ACC650 enclosure allows Inovonics EN5040-T and EN5040-20T high power repeaters to be mounted in a UL approved outdoor enclosure.

1.1 Inovonics Wireless Contact Information

If you have any problems with this procedure, contact Inovonics Wireless technical services:

- E-mail: support@inovonics.com
- Phone: (800) 782-2709; (303) 939-9336

1.2 ACC650 Enclosure

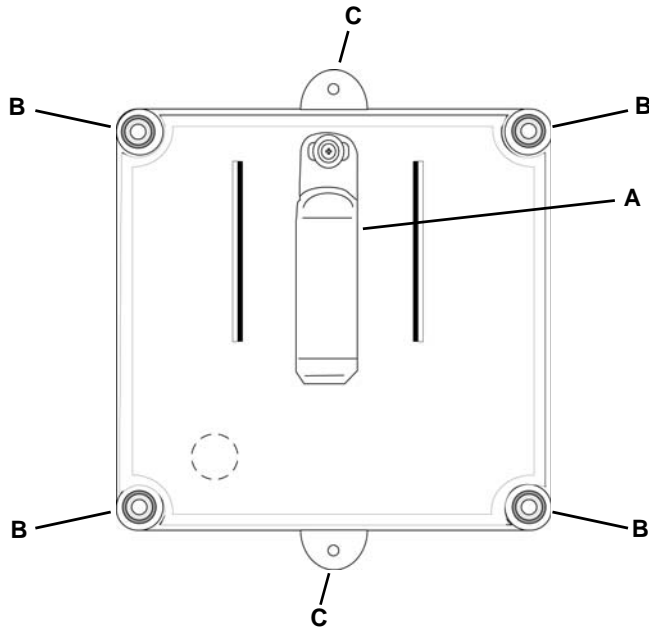

Figure 1 ACC650 enclosure

A High power repeater clip **B** Mounting hole **C** Mounting tab

2 Installation

2.1 Installation Notes

- These products are designed to be maintained by professional security technicians
- All products should be manually tested weekly

2.2 What's in the Carton

- One UL listed Type B 1/2" non-metallic liquid-tight connector

2.3 Install UL Listed Type B 1/2" Non-Metallic Liquid-Tight Connector

To meet UL 2560 requirements and weatherproof the ACC650 enclosure, it must be equipped with the included UL listed Type B 1/2" non-metallic liquid-tight connector.

1. Use a Phillips screwdriver to loosen the four plastic housing cover release screws.
2. Lift the cover off of the housing.
3. Drill a 13/16" (.8125") diameter hole to accommodate the liquid tight connector.
 - If installing the liquid tight connector on the back of the ACC650 enclosure, use the drill target shown in Figure 2.

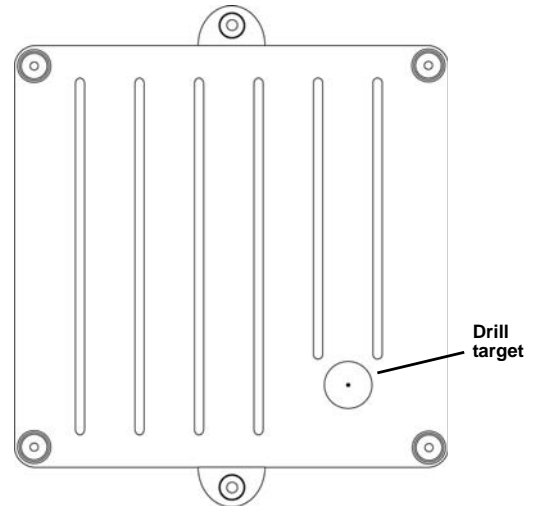

Figure 2 ACC650 enclosure back drill target

- If installing the liquid tight connector on the bottom of the ACC650 enclosure, drill the housing about 1.25" inches from the left side of the enclosure, as shown in Figure 3, at a point halfway between the front and back edges.

In the middle of the housing, roughly 1" from the front or back edge

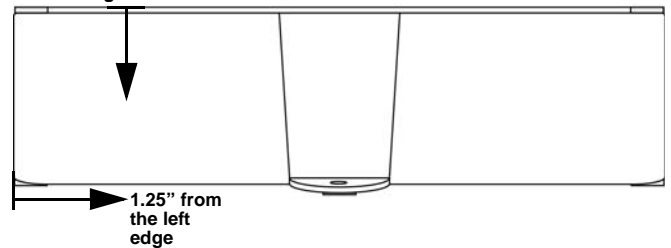

Figure 3 ACC650 enclosure bottom drill location

4. Remove all sharp edges from drilled hole.
5. Install the liquid tight connector into the drilled hole, ensuring the liquid-tight gasket is in place.
6. Thread the included locknut onto the liquid tight connector on the inside of the enclosure.
7. As desired, cut and fit UL listed Type-B 1/2" non-metallic liquid-tight conduit to meet your cabling requirements
8. Mount the the ACC650 enclosure through either the mounting holes or the mounting tabs.
9. Route cabling through the liquid tight connector and conduit and connect to the repeater per the repeater's installation instructions.
10. Insert the repeater in the repeater clip, as shown in Figure 4.

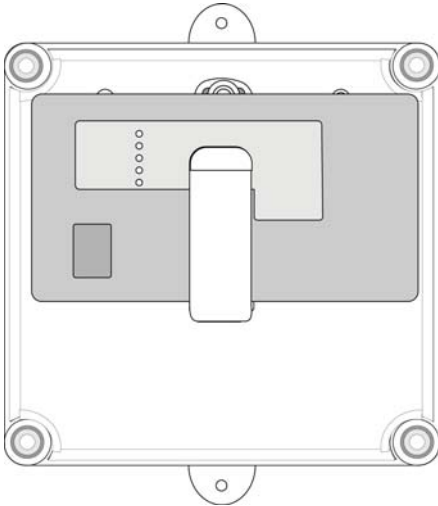

Figure 4 ACC650 enclosure with repeater installed.

3 Specifications

Compatible repeaters: EN5040-T, EN5040-20T

Dimensions: 7" x 6.75" x 3.125"

Weight: 1 lb 3.7 oz

UL 2560 certifications: EN5040-20T, ACC650

Caution: Changes or modifications not expressly approved by the party responsible for compliance could void the user's authority to operate the equipment.
