



# PEDESTRIAN GATE CLOSER SWINGER 300

HYDRAULIC



5 YEAR WARRANTY

## FEATURES & ADVANTAGES

- Tough, Dependable and Vandal Resistant.
- 2" x 4" x 12" 16 gauge galvanized Steel housing.
- Gate closer manufactured for pedestrian gates.
- Two Separate Closing and Latching valves adjustable after installation without removing the closer.
- Adjustable spring power to accommodate various size gates.
- Non Handed (right or left swing).
- Opens to full 105 degrees.
- Fully adjustable top arm for proper gate alignment.
- Adjustable zinc plated Bottom Hinge with sealed ball bearings rated for 350 lbs. Slotted Yoke for Adjustability.
- Designed to close gate into its latch position without slamming.
- Smooth operation.
- Factory tested to over 1,000,000 cycles.



## Parts List

Item	Description	Quantity	Part #
1	Housing Cover	1	311-LBC
2	Housing Box	1	311-BC
3	Arm	1	311-GB
4	Steel Plate	1	311-SP
5	Bushing	1	311-BB
14	U-Channel Arm cover	1	311-UC
15	Single Bearing Hinge (Not shown)	1	311-BH
16	Hydraulic Closer (Not shown)	1	311RVLS
<b>311 SW Screw Package Kit</b>			
6	1/4-28x1" Socket head cap screw	1	311-SW
7	3/8-24 x 1/2" #5 Hex head bolt	2	
8	3/8" USS-SAE Flat washer	2	
9	1/4-20 x 1-1/4" Flathead screws	2	
10	1/4-20 x 1/2" Button head screws	2	
11	10-32 x 1/4" Button head screw	2	
12	1/4-20 x 5/8" Socket set screw	1	
13	1/4-20 x 1/2" Socket set screw	1	

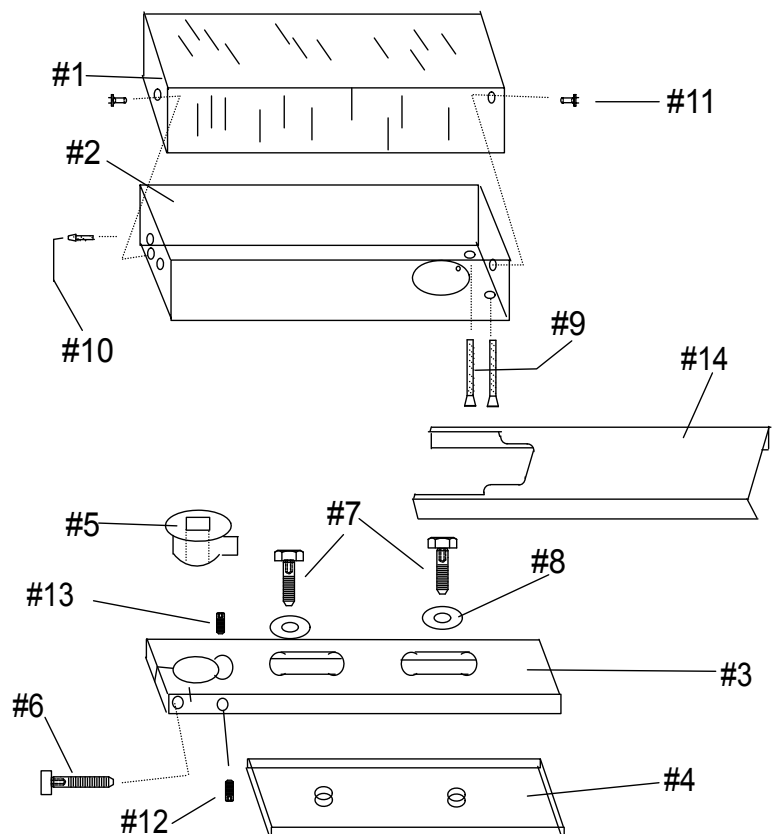

**International Door Closers, Inc.**

COPYRIGHT 2017 INTERNATIONAL DOOR CLOSERS, INC

**West: 800-544-4422 • East: 800-225-6737**

**www.intldoorclosers.com**