

FEATURES

Application:
 This 6VDC Dual-Lite approved sealed lead acid (SLA) battery, part number 0120824, is made with the highest quality components and provides 7-7.2Ah of emergency backup capacity. It supplies 3.4A @ 6V for 90 minutes to an end voltage of 5.25V, as specified by UL's Emergency Lighting and Power Equipment standard. This battery has been tested and approved to UL 924 for use with Dual-Lite's AS80, CV3, CVEC, CVT3, EZ-2, LM, LMW40I-FX, LSC, N4X and TG emergency light and exit sign products and meets pressure release test requirements specified in UL 1989.

SPECIFICATIONS

- **Part Number:** DLLT-0120824
- **Chemistry Type:** Sealed lead acid
- **Dimensions:**
 - Height (H): 4.01 inches (max)
 - Length (L): 6.01 inches (max)
 - Width (W): 1.38 inches (max)
- **Weight:** Approx. 2.69 lbs
- **Operating Temperature:** -15°C to 40°C
- **Termination:** ¼" F2 Faston terminal
- **Performance:** Provides hundreds of full discharge cycles
- Safety valve design
- Usable in any position.

Model Number	
Quantity	Type



Warning: The use of unauthorized batteries in life safety products may cause product failure and increases the risk of injury to those you or your company are trying to protect. Additionally, use of batteries that are not approved by the Original Equipment Manufacturer may void the product's warranty and exposes you or your company to increased potential for litigation. Only batteries approved by Dual-Lite are authorized for use with Dual-Lite products.

Caution: Never charge or discharge a battery in a hermetically sealed enclosure. Batteries generate a mixture of gases internally. Given the right set of circumstances, such as extreme overcharging or shorting of the battery, these gases might vent into the enclosure and create the potential for an explosion when ignited by a spark. Do not attempt to disassemble batteries. Contact with sulfuric acid may cause harm. Should it occur, wash skin with liberal amounts of water. Do not throw batteries into a fire; batteries so disposed may rupture or explode. Disassembled batteries are hazardous waste and must be treated accordingly. Sealed lead batteries must be recycled or disposed of properly.

Electrical Specifications		
Nominal Voltage	6VDC	
Rated Capacity	7 - 7.2 Ah @ 20 hour rate	
Maximum discharge current	70A (5 sec)	
Maximum charging current	1.8A	
Internal resistance	20 - 25 mOhm (fully charged @25°C)	
Constant charging voltage (25 °C)	Cycle Use	7.20 - 7.35VDC
	Standby Use	6.75 - 6.90VDC
Capacity (25 °C)	20 hour rate	7.0 - 7.2Ah
	10 hour rate	6.3 - 7.0Ah
	5 hour rate	5.6 - 6.8Ah
	1 hour rate	3.7 - 4.9Ah
Self-Discharge (25 °C)	1 month storage	90 - 97% capacity
	3 months storage	75 - 91% capacity
	6 months storage	65 - 85% capacity
	12 months storage	55 - 64% capacity

DIMENSIONS

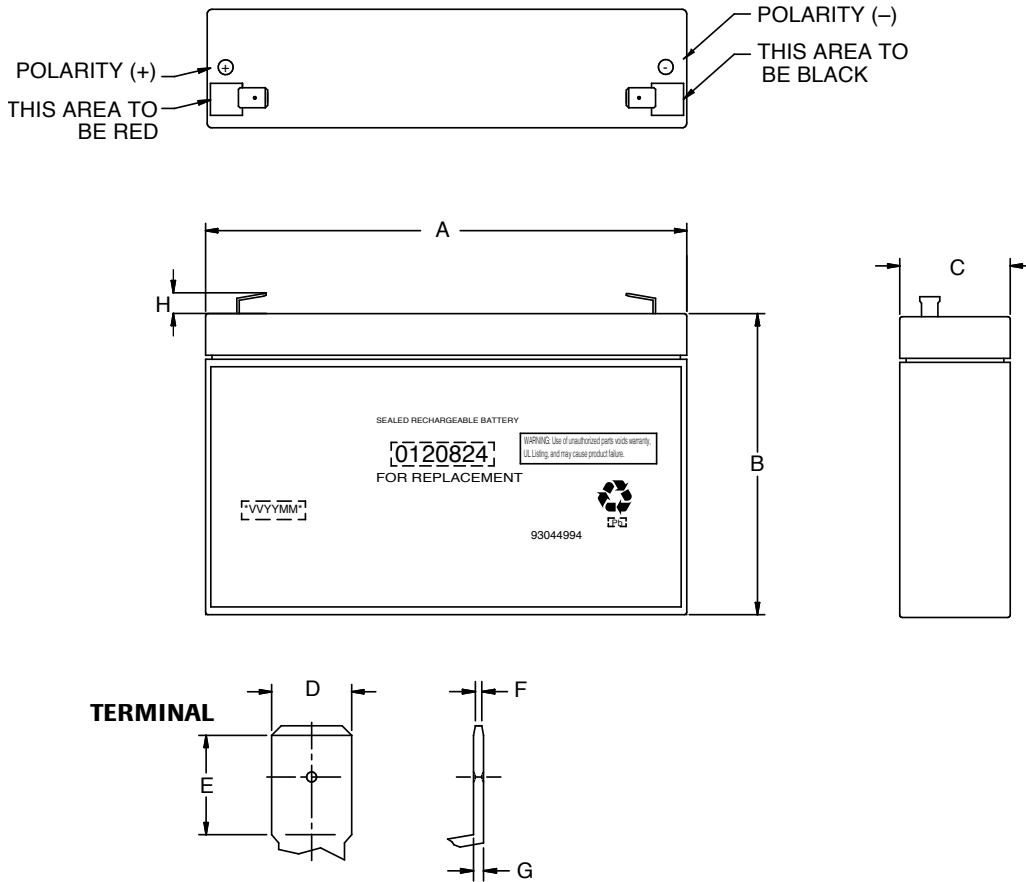

Battery Dimensions	
A	6.01
B	3.76
C	1.38
D	0.246-0.254
E	0.302-0.318
F	.020
G	0.027-0.035
H	0.25