

100' Explosion Proof Tool Tap Reel Class I, Div. I - 20 Amp EXP Receptacle Plug - GFCI Instruction Manual

Thank you for your purchase of the Larson Electronics EPLRT-100-HR-GFI.

WARNING:

READ CAREFULLY BEFORE INSTALLING FIXTURE. RETAIN THESE INSTRUCTIONS FOR FUTURE REFERENCE. CRITICAL SAFETY INSTRUCTIONS:

- INSTALLATION SHOULD ONLY BE CONDUCTED BY A QUALIFIED ELECTRICIAN IN ACCORDANCE WITH NEC AND ANY RELEVANT LOCAL BUILDING CODES.
- RISK OF FIRE OR ELECTRIC SHOCK. FIXTURE INSTALLATION REQUIRES KNOWLEDGE OF FIXTURE'S ELECTRICAL SYSTEMS. IF NOT QUALIFIED, CONTACT A QUALIFIED ELECTRICIAN.
- BE CERTAIN ELECTRICAL POWER IS OFF BEFORE AND DURING INSTALLATION AND MAINTENANCE.
- MAKE SURE THE SUPPLY VOLTAGE IS THE SAME AS THE FIXTURE'S RATED VOLTAGE.
- TO PREVENT WIRING DAMAGE OR ABRASION, DO NOT EXPOSE WIRING TO EDGES OF SHEET METAL OR SHARP OBJECTS. SUITABLE FOR DAMP LOCATIONS.

IMPORTANT

READ CAREFULLY BEFORE INSTALLING THIS FIXTURE. SAVE THESE INSTRUCTIONS FOR FUTURE REFERENCE. THE EPLRT-100-HR-GFI MUST BE WIRED IN ACCORDANCE WITH NATIONAL ELECTRICAL CODE AND ALL APPLICABLE LOCAL CODES. PROPER GROUNDING IS REQUIRED FOR SAFETY.

WE STRONGLY ENCOURAGE ONLY A LICENSED ELECTRICIAN INSTALL, OPERATE AND MAINTAIN THIS PRODUCT. IF YOU ARE NOT QUALIFIED OR UNFAMILIAR WITH ANY ASPECT OF THIS INSTRUCTION SHEET, CONSULT AN ELECTRICIAN. THERE ARE NO SERVICEABLE PARTS INSIDE.



WARNING: MAKE SURE POWER IS TURNED OFF BEFORE STARTING THE INSTALLATION OR PERFORMING ANY MAINTENANCE.

RISK OF FIRE/ELECTRIC SHOCK – DISCONNECT POWER AT BREAKER BEFORE INSTALLING OR SERVICING.

RISK OF PERSONAL INJURY – FIXTURE MAY BECOME UNSTABLE OR DAMAGED IF NOT INSTALLED PROPERLY.

RISK OF BURN – ALLOW FIXTURE TO COOL BEFORE SERVICING.

WARNING

TO AVOID THE RISK OF FIRE, EXPLOSION OR ELECTRIC SHOCK, THIS PRODUCT SHOULD BE INSTALLED, INSPECTED AND MAINTAINED BY A QUALIFIED ELECTRICIAN ONLY, IN ACCORDANCE WITH ALL APPLICABLE ELECTRICAL CODES.

TO AVOID ELECTRIC SHOCK:

- BE CERTAIN ELECTRICAL POWER IS OFF BEFORE AND DURING INSTALLATION AND MAINTENANCE.
- PRODUCT MUST BE CONNECTED TO A WIRING SYSTEM WITH AN EQUIPMENT-GROUNDING CONDUCTOR.

TO AVOID EXPLOSION:

- MAKE SURE THE SUPPLY VOLTAGE IS WITHIN THE VOLTAGE RATING.
- ENSURE THE MARKED T RATING IS LESS THAN THE IGNITION TEMPERATURE OF THE HAZARDOUS ATMOSPHERE.
- DO NOT OPERATE IN AMBIENT TEMPERATURES ABOVE THOSE INDICATED ON THE PRODUCT NAMEPLATE.
- DO NOT OPERATE IF THE LENS, CORD, SEALS, HOUSING, RECEPTACLES, ETC. IS CRACKED OR DAMAGED. IF SO, DISCONTINUE USE AND CONTACT MANUFACTURER FOR REPLACEMENT PARTS.
- ALL FASTENERS SHOULD BE PROPERLY SEATED.

WARNING:

USER SHOULD BE TRAINED IN THE PROPER USE AND MAINTENANCE OF THIS DEVICE. WHEN EXTENSION CORD IS CONNECTED TO A POWER SOURCE IN HAZARDOUS AREA, PLUG AND MATCHING RECEPTACLE MUST BE SUITABLE FOR HAZARDOUS LOCATION INVOLVED. IMPROPER USE OF THIS DEVICE, ASSOCIATED PLUG, RECEPTACLE, AND CORD CAN LEAD TO SERIOUS INJURIES OR DEATH TO PERSONNEL.

PERIODIC INSPECTION OF THE RECEPTACLE AND CORD IS NECESSARY.

THE CORD MUST BE ROUTINELY CHECKED FOR CUTS, BREAKS, OR ANY SEVERE ABRASIONS, AND IF ANY ARE FOUND, THE CORD MUST BE REPLACED BEFORE RESUMING USE OF THE UNIT.

ELECTRICAL POWER SUPPLY MUST BE "OFF" BEFORE AND DURING INSTALLATION AND MAINTENANCE. INSTALLATION AND MAINTENANCE PROCEDURE MUST BE PERFORMED BY A TRAINED AND COMPETENT ELECTRICIAN.

IF ANY PARTS OF THE RECEPTACLE OR PLUG APPEAR TO BE MISSING, BROKEN, OR SHOW SIGNS OR DAMAGE, DISCONTINUE USE IMMEDIATELY. REPLACE WITH THE PROPER REPLACEMENT PART(S) BEFORE CONTINUING SERVICE.

The EPLRT-100-HR-GFI Explosion Proof Reel w/ Tool Tap provides easy management of an included 100 feet of SOOW cord, giving operators in hazardous locations the ability to easily extend the working reach of their tools and lighting equipment. This reel is built to UL 508 table 36.1 / NEC standards and constructed of aluminum and fabricated steel for light weight and durability. The receptacle on the unit features ground fault protection for safety during operation.

PLUG OPERATION

Electrical connection between plug and compatible receptacle is accomplished after plug fully inserts into receptacle and rotated clockwise.

1. Lift receptacle door and locate polarization on mating plug pin and receptacle face. Insert plug straight all the way into receptacle until it cannot go further.
2. Rotate plug clockwise limit (37°), this closes internal contacts and completes circuit. This also mechanically locks plug into receptacle so it cannot be pulled out.
3. To remove plug, push plug inward and turn to counterclockwise, pull plug straight out.

SPECIFICATIONS

Wiring: 100' AWG SOOW Cord - Class Matching Twist-Lock Receptacle

Materials: Fabricated Steel - Aluminum

Indoor-Outdoor: NEMA 9 and NEMA 4 (IP56) Standards

Current: 30 amp, 1-4 Conductors 600 Volt, 5-12 Conductors 250 Vol

Protection: GFCI

Finish: Gray Epoxy Finish on Steel Parts

USING THE Explosion Proof Cord Reel:

These reels are also commonly referred to as "explosion-proof" or "hazardous duty" reels. They are built with modular "1400 Series" components, coupled with a spark-proof ratchet and explosion-proof slip ring housing.

Reels operate best when the cable is pulled no more than 15 degrees from parallel with the guide, and retracted the same way. For greater payout angles, we recommend adding a pivot base or swivel base.

Notice: *If the reel is expected to payout and retract at a very high cycle rate, or is operating in an exceptionally harsh environment, you may need Premium Cable – contact us for details.*

INSTALLATION

Stretch Applications



The cable is suspended without any intermediate support. Stretch reels generally require a line pull equal to two times the weight of the cable, which allows approximately 10% sag at full extension. On long applications where sag cannot be tolerated, it is sometimes desirable to put supports at intervals of 5 to 10 feet.

Drag Applications



The reel is mounted on a stationary object and is required to drag the cable over the surface to the reel. The cable is supported by the ground or some type of cable tray.

Lift Applications



The cable is lifted vertically in lift applications. The reel is normally designed to handle only the total weight of the cable. Some lift applications may require a ball stop and ratchet to control the length of cable to be retracted.

Retrieve Applications

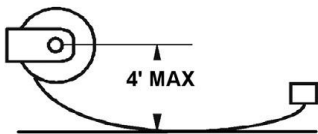

The reel is mounted on the moving object and winds up or pays out the cable as the machine approaches or moves away from the fixed end. Retrieve applications can be elevated up to 4 feet from the cable support surface.

MOUNTING

Standard Mounting

1. The reel may be mounted by bolting the base to any flat surface which is structurally sound enough to support it and the forces of winding and unwinding the cable.
2. The spool drum must rotate on a level horizontal axis.
3. Position the guide arm so that cable payout is perpendicular to the face of cable roller guide.

The total cable deflection should not exceed 15° to either side of the centerline of the spool.

4. If deflection is constant to either side of the reel and operation is impaired, re-mount the reel.
5. If the angle of deflection exceeds a Pivot Base should be used, otherwise excessive cable wear and unreliable operation will result.
6. A safety chain is recommended for all overhead installations. Attach the safety chain using the 0.39 hole provided in the base.

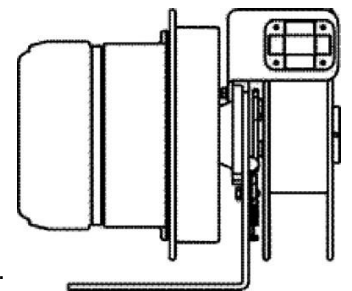

Cable Deflection with Roller

Pivot Base Mounting

1. All EXPCRL cable reels can be furnished with a spark proof pivot base to allow the reel to rotate and keep the extended cable perpendicular to the application.
2. The pivot base has the ability to rotate up to 340°. This pivot base is not suitable for applications requiring continuous rotation.
3. A pivot base is required carousel or loop-track applications.
4. When a pivot base is used, the reel must be mounted horizontally (ceiling or floor mounted).
5. The roller guide should be mounted so the cable will travel perpendicular to the axis of rotation. This will guard against the cable twisting and ensure effective swivel action from the pivot base.
6. Selection of mounting holes should be such that the spool center is in line with the center point of the pivot base.

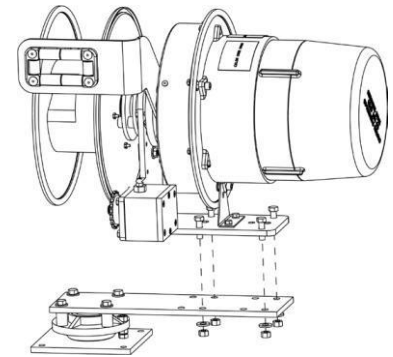

Reel with Pivot Base

Roller Guide

1. All EXPCRL units are equipped with a roller guide arm. The function of the guide is to center the cable on the spool and to help the reel cable more evenly.
2. The cable should not pile against either end of the spool during winding as this will tend to inhibit level winding of the cable.
3. The guide should be secured at the best of twelve possible positions so that a minimum change of direction occurs at the guide; otherwise, cable life will be reduced.
4. The guide is shipped installed on the reel. The guide must be aligned per application and secured prior to making any electrical connections
5. Mount the roller guide to the reel over the entrance coupling on the frame. Secure using the provided 3/8-16 hex head cap screw, including the split lock washer. Tighten this to 15 ft.-lbs.

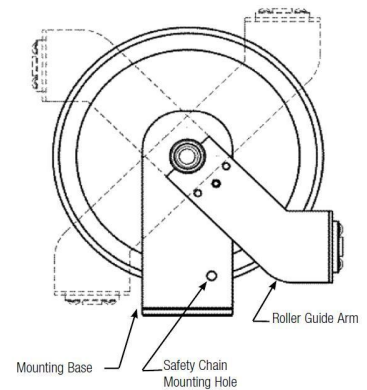

Roller Guide Locations

Ratchet

- The ratchet lock can be activated or deactivated, depending upon the application.

Operation with Ratchet

- The ratchet on the EXPCRL is spring loaded. It is designed to function in all acceptable mounting configurations.

Operation without Ratchet

- Deactivate the ratchet by pivoting the lock-out bar to the lower position. This will remove the ratchet pawl from the path of the ratchet plate. Locate the dimple on the lock out bar in the hole provided.

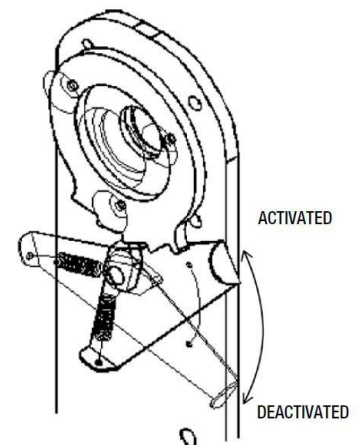

Ratchet Lock

WARNING: Do not activate the ratchet abruptly. Sudden activation may cause excessive shock loads to the ratchet pawl which may cause lock-up and/or breakage.

Cable Installation

Cable is factory installed and sealed. Consult factory for changes.

Spring Tension Adjustment

WARNING: Do not allow cable to retract without restraining the retraction speed. Walk the cable back to the reel during the spring tension adjusting process. Always maintain two full cable wraps on drum at maximum cable extension, size cable accordingly.

1. The EXPCRL reels come with pre-tension from the factory. Some adjustments may be required to meet specific application requirements.
2. To assure that the cable will retract properly and operate under the correct tension for intended application; the reel should be tested. Securely mount reel before testing with cable installed on drum and end of spool cable not connected, proceed with the next steps.
3. Pull the cable out to the intended travel distance and allow it to rewind. This procedure should be repeated five (5) to ten (10) times in order to set the spring. Walk the cable back to the reel during the spring tension adjusting process.

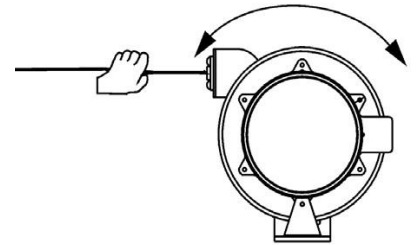

Rotate Spool while holding Cable to Test the Spring Tension

4. With all the cable wound on the reel, grasp the end of the cable and rotate the drum and cable together in the direction of pay out in order to pre-tension the spring. The number of pre-tension turns is determined by cable size and footage. Usually, four to sixteen turns is sufficient, but additional turns may be used if testing indicates that the cable will not fully retract as desired with just four turns.
5. Feed the end of the cable through the cable guide and pull the cable out the required length.
6. Repeat steps 3 to 5, if necessary, to add tension. To decrease tension, rotate drum and cable counter-clockwise

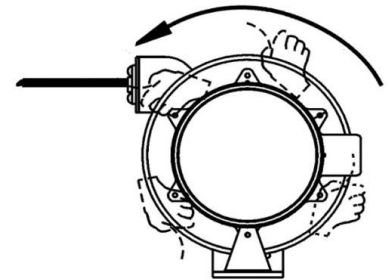

Adding Spring Tension

Power Connections

1. Provide power source with over-current protection to prevent overheating of the reel and cable.
2. Reels are supplied with 6' feeder cords. Those cords are the same cable as is supplied on the spool. They are factory sealed with explosion proof potting compound and supplied with a watertight strain relief. If a conduit connection is required, the strain relief must be removed and conduit connections made.

OPERATION

1. Do not exceed the voltage or amperage for the cable. Overheating, fire, damage to equipment or personal injury could result.
2. Do not allow cable to retract without restraining the retraction speed.
3. Operate the reel within the cable size and length and spring tensioning limits for which it was intended.
4. Keep two wraps of cable on the reel at maximum extension to avoid excessive tension on the cable and to prevent pullout of cable from entrance watertight.

MAINTENANCE

WARNING: Be sure all power is off for all maintenance.

Lubrication

1. All components requiring lubrication are lubricated for life at the factory. Additional lubrication is not required.
2. Do not apply any lubricants or solvent cleaning agents to slip ring, brush or insulator surfaces.

Inspections

1. Periodically check the reel for any loose or missing fasteners. Tighten or replace as necessary.
2. The slip ring assembly should be checked periodically as follows:
 - Clean to remove dust and dirt from the slip ring housing area and all slip ring assembly and brush surfaces.
 - Brushes should be centered on slip rings and brush springs should be seated in terminal post grooves. Terminal screw connections should be tight. Check for excessive brush wear, Replace brushes as necessary.
 - Inspect cable for damage or wear which would make it unsafe to use.

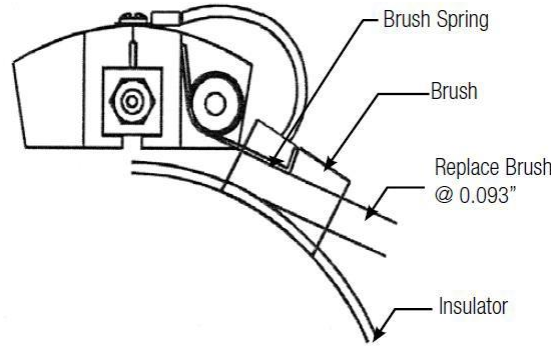

Slip Ring Replacement

1. **NOTE:** The slip ring assembly should be replaced, not rebuilt, if it becomes damaged.
2. Due to factory sealing of explosion proof unit, slip ring replacement should only be done by the factory.

Cable Replacement

1. Cable replacement should only be attempted by the factory. This is due to the cable being epoxy sealed into the entrance ring.

Spring Motor Replacement

1. **CAUTION:** Do not open the spring motor or personal injury may result.
2. Due to spool cable being sealed in the shaft, spring motors can only be factory rebuilt and replaced.

TROUBLESHOOTING

PROBLEM	POSSIBLE CAUSE	SOLUTION
Reel will not retract cable but has some tension	<ol style="list-style-type: none"> 1. Improper pretension 2. Incorrect reel for application (lift vs. stretch) 3. Cable guide adjustment 	<ol style="list-style-type: none"> 1. See section "Spring Tension Adjustment" 2. Quantify application vs. reel selection 3. Check guide alignment
Reel does not have any spring tension	<ol style="list-style-type: none"> 1. Broken spring. Quantify application to prevent recurrence 	<ol style="list-style-type: none"> 1. Factory rebuild
Ratchet will not activate	<ol style="list-style-type: none"> 1. Broken ratchet pawl spring 2. Lock-out option arm deactivated 	<ol style="list-style-type: none"> 1. Replace ratchet pawl spring 2. Activate lock-out arm

Ratchet will not deactivate	<ol style="list-style-type: none"> Over-extension of reel 	<ol style="list-style-type: none"> Manually rotate reel spool to deactivate ratchet. Do not over-extend. (Guide adjustment may prevent lock –up when over-extended)
Cable wraps improperly (uneven wrapping, wraps above or jumps flange)	<ol style="list-style-type: none"> Reel mounting no level Cable retraction rate too high Cable guide out of adjustment 	<ol style="list-style-type: none"> Mount reel on level surface Maintain steady retraction rate Properly adjust cable guide
Cable twisting and knotting	<ol style="list-style-type: none"> Improperly installed cable Cable rubbing on or bending around fixed object Excessive spring tension Inadequate anchoring of cable 	<ol style="list-style-type: none"> See section “Cable Installation” Check roller guide for function and cable payout path Quantify application vs. reel selection Also check pretension Adjust anchoring method i.e. and strain relief
Open or intermittent circuit	<ol style="list-style-type: none"> Inadequate connection Loss of brush contact to slip ring Cable defective 	<ol style="list-style-type: none"> Check all termination points Check brush wear, spring tension & alignment Perform continuity check on cable termination points
Circuit trips and/or pitted burned rings or brushes	<ol style="list-style-type: none"> Inadequate amp rating of reel selection 	<ol style="list-style-type: none"> Quantify application requirements vs. reel and cable rating
Circuit arcing	<ol style="list-style-type: none"> Amp or voltage above rating of reel Excessive carbon dust accumulation Loss of brush to ring contact 	<ol style="list-style-type: none"> Quantify application requirements vs. reel and cable rating Clean dust from inside slip ring Replace brush and/or brush spring

USING THE EXPLOSION PROOF EXTENSION CORD:

- Position Explosion Proof Extension cord near equipment to be powered.
- Run cable to compatible receptacle.
- Attach power to **voltage specified on product label.**
- Attach equipment to receptacle.

WARNING: *This unit comes preconfigure to work with voltage specified upon purchase. Double check product label for correct voltage before operating!*

GROUND-FAULT CIRCUIT INTERRUPTER (GFCI)

In the event of a ground fault, a GFCI will trip and quickly stop the flow of electricity to prevent serious injury.

Definition of a ground fault:

Instead of following its normal safe path, electricity passes through a person's body to reach the ground. For example, a defective appliance can cause a ground fault.

A GFCI receptacle does **NOT** protect against circuit overloads, short circuits, or shocks. For example, you can still be shocked if you touch bare wires while standing on a non-conducting surface, such as a wood floor.

NOTE:

GFCI's contain a lockout feature that will prevent RESET if:

- There is no power being supplied to the GFCI.
- The GFCI is miswired due to reversal of the LINE and LOAD leads.
- The GFCI cannot pass its internal test, indicating that it may not be able to provide protection in the event of a ground fault.

GFCI TEST

Use an approved GFCI tester or plug an electrical device, such as a lamp into the receptacle on which you are working. Turn the lamp or device ON. Then, press the TEST button on the GFCI box and power should immediately be switched off. If not, contact an electrician. Press the RESET button to restore power.

MAINTENANCE:

Electrical and mechanical inspection of all components must be performed on a regularly scheduled basis, determined by the environment and frequency of use. It is recommended that inspection be performed a minimum of once a year.

WARNING: ELECTRICAL POWER SUPPLY MUST BE "OFF" BEFORE AND DURING INSTALLATION AND MAINTENANCE. INSTALLATION AND MAINTENANCE PROCEDURE MUST BE PERFORMED BY A TRAINED AND COMPETENT ELECTRICIAN.

WARNING: IF ANY PARTS OF THE RECEPTACLE OR PLUG APPEAR TO BE MISSING, BROKEN, OR SHOW SIGNS OR DAMAGE, DISCONTINUE USE IMMEDIATELY. REPLACE WITH THE PROPER REPLACEMENT PART(S) BEFORE CONTINUING SERVICE.

If any part of the plug appears to be missing, broken, or show signs of damage—discontinue use immediately! This condition could cause serious or fatal personal injury due to electrocution and/or equipment damage. Repair with the proper replacement part(s) before continuing service.

During the inspections, perform the following steps:

1. Inspect all contact wire terminals for tightness and re-torque if necessary. NOTE: Discoloration due to excessive heat is an indicator of potential issues and should be thoroughly investigated and repaired as necessary.
 2. Explosion Proof Plugs: Check grounding and bonding for correct installation. Secure connections and retorque if necessary.
 3. Check gaskets for deterioration and replace if necessary.
 4. Clean exterior surfaces to ensure the nameplates remain legible.
 5. Inspect cable grip tightness to ensure proper cord/cable gripping.
 6. Torque all screws as described in the "Installation" section before reusing the device.
 7. Inspect all parts and replace those which are broken or excessively worn.
 8. Check the contacts for signs of excessive arcing or burning and replace if necessary.
- Do not use cable different from that for which the reel is intended. Changes in diameter, weight per foot, length of cable or flexibility will affect the operation of the reel.
 - Mounting hardware and fasteners should be installed to maintain tightness under vibration and checked periodically to assure tightness.
 - Overhead installation mountings should be such that the reel is not suspended by bolts in tension. A safety chain or cable is strongly recommended to minimize damage and/or possible injury in the event of mounting failure.
 - **WARNING:** Modifications of this equipment may cause excessive wear and will void the warranty. Contact the manufacturer regarding changes or modifications of equipment which could affect reliability or safety.

USE AND CARE

Unauthorized modification may impair the function and/or safety of this device and could affect the life of the equipment. Always check for damaged or worn out parts before using the device. Store it in a secure place out of the reach of children when not in use. Inspect for good working condition prior to storage and before re-use.

REPLACEMENT PARTS

The EPLRT-100-HR-GFI is designed to provide years of reliable performance. Should the need for replacement parts arise, please contact Larson Electronics.

THESE INSTRUCTIONS MAY NOT COVER ALL DETAILS OR VARIATIONS OF THIS PRODUCT FOR YOUR EQUIPMENT OR INSTALLATION REQUIREMENTS. SHOULD FURTHER INFORMATION NOT COVERED BY THESE INSTRUCTIONS BE REQUIRED, PLEASE CONTACT LARSON ELECTRONICS BY EMAIL AT SALES@LARSONELECTRONICS.COM OR BY PHONE AT 1-800-369-6671 FOR FURTHER ASSISTANCE.

PLEASE VISIT LARSONELECTRONICS.COM FOR **WARRANTY** AND **RETURN** INFORMATION.