

INSTRUCTION SHEET

INSTRUCTION FOR INSTALLATION AND MAINTENANCE OF POWERTITE® SERIES: PIN AND SLEEVE RECEPTACLES, PLUGS AND CABLE CONNECTORS (30, 60, 100 AND 150 AMPERE) FOR USE WITH COPPER CONDUCTORS ONLY

Electrical Rating

Maximum Voltage: 600 VAC at 50-400Hz, 250V DC; Maximum Continuous Current: 30, 60, 100 or 150 Amperes.

APPLICATIONS

- Designed to supply power to portable or fixed electrical equipment such as motor generator units, welders, pumps, compressors and similar apparatus.
- Ideal for use on shipping docks, ports and other "ship to shore" applications.
- Suitable for use in locations where a watertight enclosure is required.
- Rough usage construction.

FEATURES

- Rugged.** All components have copper-free aluminum housings.
- Two Grounding Styles.** Copper grounding straps in Style 2 receptacles and plugs (shown) ground thru shell and extra pole. Style 1 thru shell only.
- Convertible.** Two screws secure receptacle insulator block; one screw secures plug insulator block. Permits easy conversion to reverse service (30, 60, 100A).
- Watertight.** Mounting box sealed with gasket. Receptacle and connector seals with screw cap or plug. Plug sealed when in receptacle or connector.
- Insulator Blocks.** Provide high mechanical and dielectric strength, very low "arc tracking".
- Positive Ground.** Grounding detent springs assure maintained ground contact.
- Self-Aligning.** "Floating" plug and receptacle contacts automatically align.
- Arcing Confined.** Contacts made and broken in snuffing chamber. In emergency, plugs can be withdrawn under full rated loads (30A thru 100A). Positive polarization helps prevent mismatching plugs.
- Positive Contacts.** Brass contacts have integral springs for positive maintained electrical contact.
- Clamping Ring, Plug.** Neoprene gasketed, 30A, 60A, 100A, 150A plugs thread onto receptacle for watertight union.
- Positive Cable Clamp.** Plugs supplied with neoprene bushing and a reversible cable clamp for firm, watertight fit over a wide range of cable diameters. Locking screw prevents Gland Nut from turning.

COMPLIANCES:

UL Standards 1682, 1686 (all) and 1010/1203 (plugs only); CSA Specification C22.2 No. 182.1 Enclosure Type 3, 4, 4X

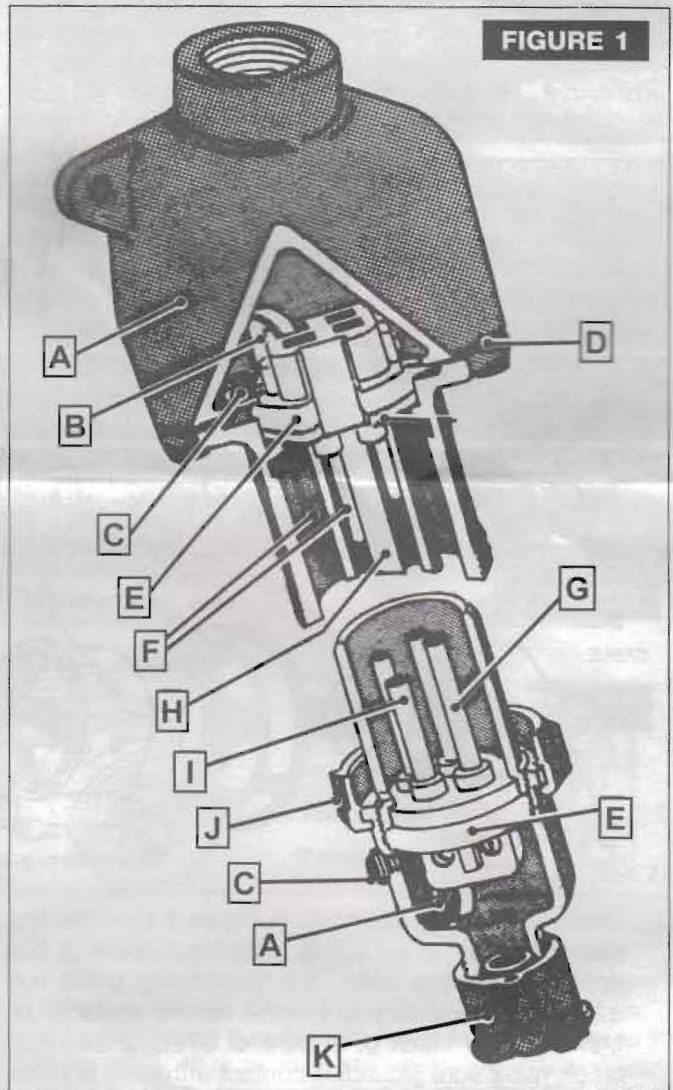

Style 2 Powertite Plugs, Receptacles and Cable Connectors are equipped (since mid-1990) with contacts designed to provide a safety polarization means called "**Controlled Length**" contacts, as indicated on product nameplate. This feature will not allow the plug grounding contact (Style 2) to touch an energized receptacle "line" contact in the event the plug becomes damaged and/or loses its primary polarization means and/or is rotated into the incorrect position.

RETAIN THIS INSTRUCTION SHEET FOR FUTURE REFERENCE.

READ INSTRUCTIONS CAREFULLY AND WITH FULL UNDERSTANDING FOR SAFE INSTALLATION AND OPERATION.

Except as expressly provided by Appleton Electric (Appleton) in writing, Appleton products are intended for ultimate purchase by industrial users and for operation by persons trained and experienced in the use and maintenance of this equipment and not for consumers or consumer use. Appleton warranties do not extend to and no reseller is authorized to extend Appleton's warranties to any consumer.

CAUTION

To prevent ignition of hazardous atmospheres do not use in Class 1, Group F locations that contain electrically conductive dusts.

WARNING

Use cable with diameters within the specified range given in TABLE B for any given grommet size and clamp orientation. Failure to do so may result in over stressed wire terminations which could cause the conductors to pull out of the contacts and cause serious/fatal injuries due to electrocution or fire.

WARNING

Do not modify these devices in any way.

Replace any missing or broken parts with proper replacements parts from Appleton Electric. Modification of these devices or substitution of parts with non-standard parts may result in serious/fatal personal injury from electrocution.

CAUTION

ACP series plugs may be mated with Powertite Series Receptacles in ordinary locations and with the DBR, MD2SR, JBR, EBR and EBRH Series Receptacles for use in hazardous (classified) locations as defined in the National Electrical Code and the Canadian Electric Code. Portable utilization equipment connected to the ACP Series plug must be approved for use in the intended location. Equipment **NOT** approved for use in hazardous locations as defined by the N.E.C. and C.E.C., connected to an ACP plug must be used in non-hazardous locations. If used in a hazardous area, the equipment must be approved for that location, or the area must be purged of the hazard and declared non-hazardous.

WARNING

If any parts of the plug, receptacle or cable connector appear to be missing, broken or show signs of damage;

DISCONTINUE USE IMMEDIATELY!

This condition could cause serious/fatal personal injury due to electrocution and/or equipment damage. Repair with proper replacement part(s) before continuing service.

WARNING

Electrical power must be turned "OFF" before and during installation and maintenance. **Failure to do so may result in serious/fatal injuries due to electrocution.**

Plug is watertight when inserted in proper receptacle or cable connector and the clamping ring is fully tightened.

**INSTALLATION INSTRUCTIONS FOR POWERTITE "ACP" PLUGS:
30A, 60A, 100A, 150A**

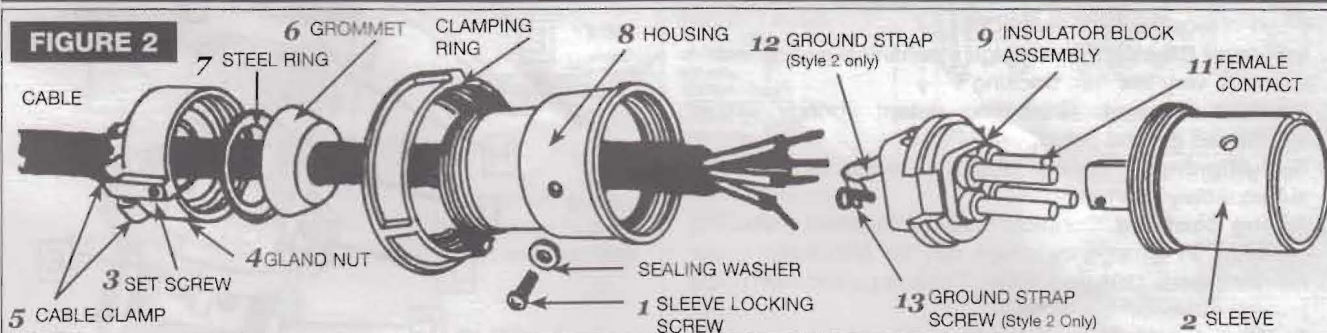

1. Disassemble plug as shown in Figure 2 by removing sleeve locking screw **1** and loosen set screw **3** (for applicable models only), and unscrewing gland nut **4**. It is not necessary to remove female contacts **11** from insulator block **9**. In case of STYLE 2 insulator block, make sure grounding contact with strap is in the proper location. See Figure 4.
2. Strip the cable jacket and individual conductors per Table "A".
3. Select proper grommet **6** and cable clamp **5** orientation per Table "B". Reversible cable clamps (just removescrews, flip over and replace



- screws) permit wide cable range. Convenient in installations having different cable sizes. See Figure 8.
4. Slide gland nut **4**, steel ring **7**, proper grommet **6** and housing **8** in that order back over cable.
5. Connect wires to proper terminals in insulator block by loosening (but not removing) terminal pressure screws on contacts. Then insert conductors including all strands into contact terminals according to your established wiring scheme. Tighten terminal pressure screws to a torque value per Table C. (Conductors must bottom in contact terminal well and insulation must extend below surface of insulator block.) See Figure 3.

Continued on next page...

- Position insulator block assembly **9** in sleeve **2**. For STYLE 2, attach ground strap **12** to sleeve **2** with ground strap screw and torque in 25 in. lb. min. / 30 in. lb. max. Screw the combination of sleeve and contact block assembly into housing **8** until the threaded hole in sleeve **2** is aligned with the hole in housing **8**. Thread in sleeve locking screw **1** including sealing washer and torque to 30 in. lb. min. / 35 in. lb. max.
- Slide grommet **6** and steel ring **7** up and as close to housing as possible. Force cable into wiring cham-

ber to induce a minimum of 1/8 in. slack in the wire between clamp and terminal. Screw gland nut **4** onto housing **8** and torque per Table "C". Finally torque the set screw **3** (for applicable model only) in place at 10 in. lb. min. / 15 in. lb. max.

- Refer to Table "B" and Figure 8 for correct cable clamp orientation. Tighten cable clamp screws to 30 in. lb. min. / 35 in. lb. max. Screws were lubricated at the factory but if needed, relubricate with a good grade of grease.

WARNING

A wire scheme must be followed so that the same color wire is always put into the same numbered contact opening in all plugs, connectors and receptacles in the system. This will help insure correct polarity for the system and helps to eliminate possibilities for equipment damage and/or personal injuries due to electrocution or fire.

ELECTRICAL TESTING

Do not connect to power until conducting the following electrical tests.

- Test continuity of wiring to verify correct phasing and grounding connections.
- Measure insulation resistance to be sure system does not have any short circuits or unwanted grounds.

FIGURE 3

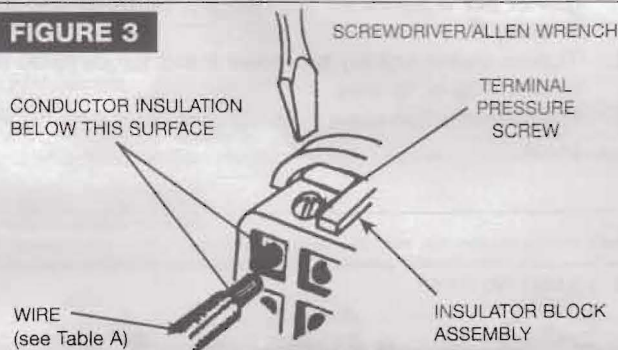
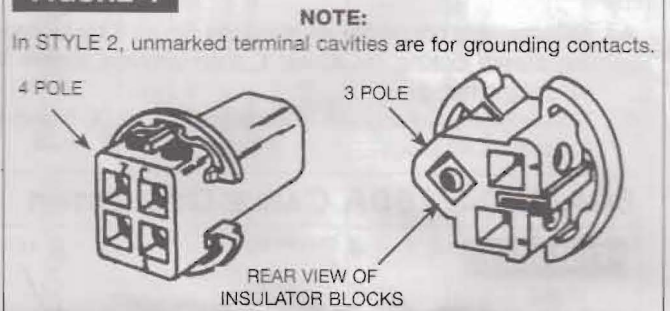
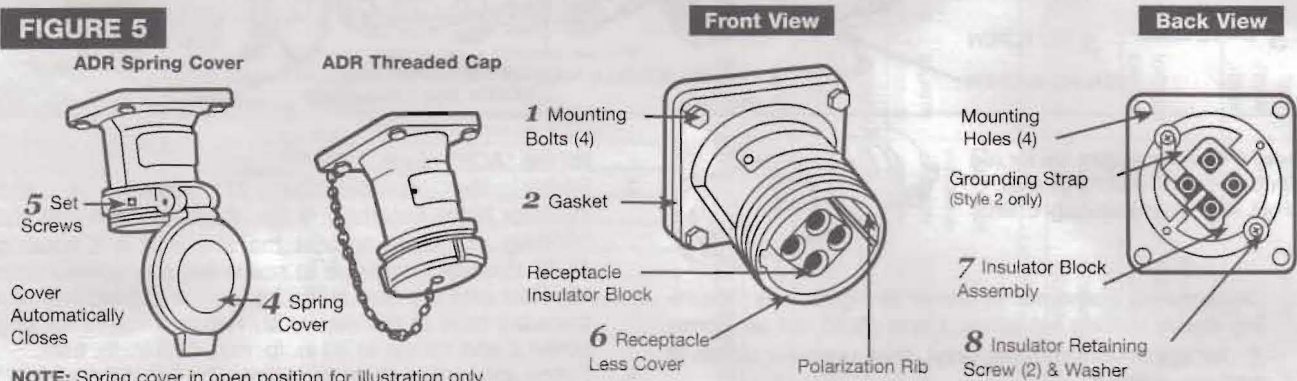

FIGURE 4



INSTALLATION INSTRUCTIONS FOR POWERTITE "ADR" RECEPTACLES: 30A, 60A, 100A, 150A

FIGURE 5



NOTE: Spring cover in open position for illustration only.

Spring Cover and Screw Cover receptacles are threaded to accept the clamping ring of the ACP plug. The ring threads onto the receptacle to form a watertight assembly with plug in use and also to prevent plug fallout. When the plug is withdrawn, the gasketed Spring Cover automatically closes tightly against receptacle opening providing weather-proof protection.

- Follow instruction given in paragraphs 2 and 5 for "ACP" plugs.
- Insert insulator block assembly **7** into receptacle housing **6** and install two retaining screws with washers **8**. Torque to 30 in. lbs. min. / 35 in. lbs. max.

3. Mount receptacle to previously installed back box using mounting bolts **1** supplied with receptacle and torque to 30 in. lb. min. / 40 in. lb. max. Mounting screws provide electrical continuity between receptacle housing **6** and back box. Make sure gasket **2** is positioned correctly to make a watertight seal.

- The spring cover can be positioned to open in any direction by loosening the set screws **5**, repositioning the spring cover **4**, and retightening the set screws **5**. Torque set screws **5** to 7 in. lb. min. / 12 in. lb. max.

INSTALLATION INSTRUCTIONS FOR POWERTITE "ARC" RECEPTACLES: 30A, 60A, 100A, 150A

30A CABLE CONNECTOR

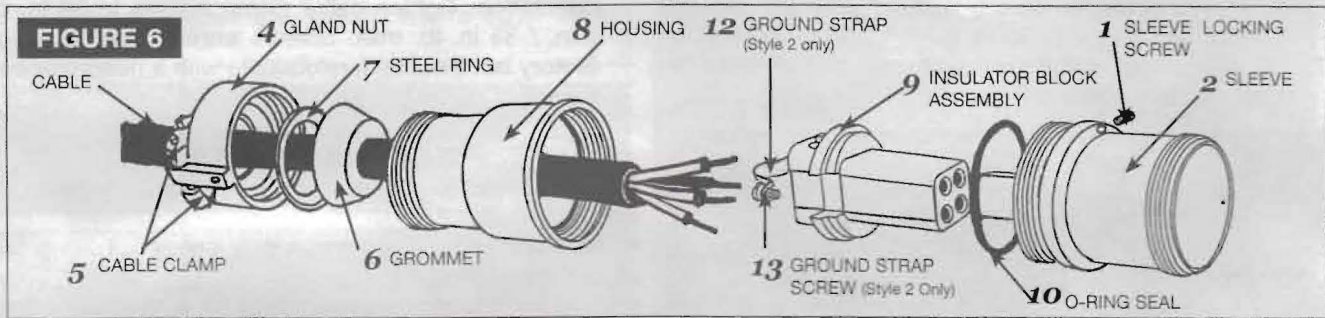

These Cable Connectors are for use with "ACP" Powertite Plugs and others. See Intermateability Chart

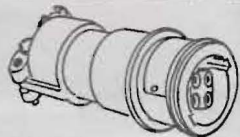

1. Disassemble connector as shown in Figure 6 by loosening sleeve locking set screw **1**, then unscrew sleeve **2** and gland nut **4**.
2. Follow instructions given in paragraphs 2, 3, 4, 5 and 6 for the "ACP" plugs.
3. Screw the combination of sleeve and insulator block assembly into the housing **8** until the gasket **10** is tightened between the sleeve **2** and the housing **8**.
4. Tighten sleeve locking set screw **1** and torque to 30 in. lb. min. / 35 in. lb. max.
5. Follow instruction given in paragraphs 7 and 8 for "ACP" plugs.

60A/100A/150A CABLE CONNECTOR

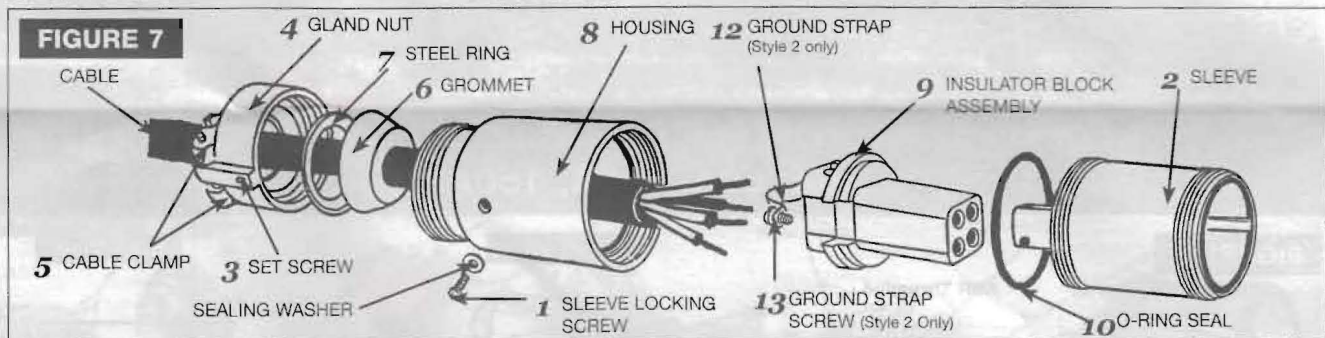

These Cable Connectors are for use with "ACP" Powertite Plugs and others. See Intermateability Chart

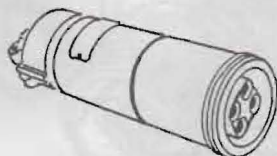

1. Disassemble connector as shown in Figure 7 by loosening sleeve locking set screw **1** and gland nut set screw **3** (for applicable models only), then unscrew sleeve **2** and gland nut **4**.
2. Follow instructions given in paragraphs 2, 3, 4, 5 and 6 for the "ACP" plugs.
3. Screw the combination of sleeve and insulator block assembly **9** into the housing **8** until the "O"-ring **10** seats against the sleeve **2** and housing **8**. At this point continue to screw the two components together until the hole in the housing is aligned with the threaded hole of the sleeve **2**. Replace sleeve locking screw **1** and torque to 30 in. lb. min. / 35 in. lb. max.
4. Follow instruction given in paragraphs 7 and 8 for "ACP" plugs.

TABLE A DIMENSIONS IN INCHES

Terminal Wire Range and Stripping Guide, Copper Conductors Only

Amperes Ratings	Strip Length (inches)		Terminal Wire Range (AWG)	
	Jacket	Conductor	Building	Extra Flex
	A	B		
30	1-1/2	1/2	#10 - #6	#10 - #8
60	1-7/8	5/8	#6 - #2	#6 - #4
100	2-1/2	7/8	#4 - #1	#4 - #2
* 150 (CD)	2-1/2	7/8	#2 - 2/0	#2 - 1/0
* 150 (DE)	4.0	7/8	#2 - 2/0	#2 - 1/0

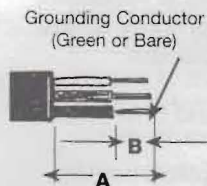

* For 150 AMP Rating:

Size AWG	Temperature Rating of Conductor	
	75°C	90°C
#2	115 AMP	130 AMP
#1	130 AMP	150 AMP

CAUTION

Plug and cord connectors are rated for use with Type SO or equivalent portable cord with copper conductors ONLY.

CAUTION

Care must be taken not to cut into the individual conductor insulation when removing the outer cable jacket and to not damage the conductors when removing individual wire insulation. Failure to do so will seriously degrade the electrical properties of the cable and may produce overheating/electrical hazard due to electrocution.

TABLE B

DIMENSIONS IN INCHES

Grommet Selection and Cable Clamp Orientation Guide (Figure 8)

AMP SIZE & CAT. NO.	CABLE DIA. RANGE (in.)	GROMMET I.D. (in.)	REVERSIBLE CLAMP POSITION
30 AMP			
ACP30xxBC ARC30xxBC	.390-.625 .625-.812 .812-1.125	.625 .812 1.125	1 1 1
60 AMP			
ACP60xxBC ARC60xxBC	.625-.812 .812-1.125 1.125-1.375	.812 1.125 1.375	1 1 2*
100 & 150 (CD) AMP			
ACP10xxCD ARC10xxCD ACP15034CD	.875-1.062 1.062-1.281 1.281-1.562 1.562-1.906	1.062 1.281 1.562 1.906	1 1 2 2
150 AMP ACP15034DE	1.25-1.28 1.28-1.56 1.56-1.91 1.91-2.19	1.28 1.56 1.91 2.19	1 1 3 2

*Clamps B & C were replaced by clamp BC; also C & D replaced by CD. Some products with a B or C catalog number suffix were shipped with a BC clamp installed. Same for C or D but with a CD clamp.

Figure 8

To reverse cable clamp, just remove screws, flip over and replace screws. Permits a wider cable range. Convenient in installations having different cable sizes.



1st POSITION



2nd POSITION



3rd POSITION

ACP plugs are supplied with four bushings to accommodate a wide variety of cable diameters.



For minimum torque tightening, see Table C.

Table C

Gland Nut and Terminal Tightening Torque Guide

Device AMP Rating	Gland Nut	Terminal
30 A	60.0	35.0
60 A	60.0	40.0
100 A	72.0	50.0
150 A (CD)	72.0	80.0
150 A (DE)	80.0	80.0

Min. Tightening Torque (in. lb.)

INTERMATEABILITY CHART FOR ORDINARY LOCATION PLUGS & RECEPTACLES

	30A				60A				100A						
	2W, 2P	3W, 3P	4W, 4P	2W, 3P	3W, 4P	2W, 2P	3W, 3P	4W, 4P	2W, 3P	3W, 4P	2W, 2P	3W, 3P	4W, 4P	2W, 3P	3W, 4P
APPLETON															
Plugs	ACP3022BC	ACP3033BC	ACP3044BC	ACP3023BC	ACP3034BC	ACP6022BC	ACP6033BC	ACP6044BC	ACP6023BC	ACP6034BC	ACP1022CD	ACP1033CD	ACP1044CD	ACP1023CD	ACP1034CD
Cable Connectors	ARC3022BC	ARC3033BC	ARC3044BC	ARC3023BC	ARC3034BC	ARC6022BC	ARC6033BC	ARC6044BC	ARC6023BC	ARC6034BC	ARC1022CD	ARC1033CD	ARC1044CD	ARC1023CD	ARC1034CD
Receptacles	ADR3022	ADR3033	ADR3044	ADR3023	ADR3034	ADR6022	ADR6033	ADR6044	ADR6023	ADR6034	ADR1022	ADR1033	ADR1044	ADR1023	ADR1034
	ACR3022	ACR3033	ACR3044	ACR3023	ACR3034	ACR6022	ACR6033	ACR6044	ACR6023	ACR6034	ACR1022	ACR1033	ACR1044	ACR1023	ACR1034
				WRDK3034							WRDK6034			WRDK1034	
				WRDK30SQ							WRDK60SQ			WRDK10SQ	
				312737							312726			312738	
CROUSE-HINDS															
Plugs	APJ3275	APJ3375	APJ3475	APJ3385	APJ3485	APJ6275	APJ6375	APJ6475	APJ6385	APJ6485	APJ10277	APJ10377	APJ10477	APJ10387	APJ10487
				NPJ3383	NPJ3483				NPJ6384	NPJ6484				NPJ10386	NPJ10486
				NPJ3384	NPJ3484				NPJ6385	NPJ6485				NPJ10387	NPJ10487
Cable Connectors	APR3253	APR3353	APR3453	APR3363	APR3463	APR6253	APR6353	APR6453	APR6363	APR6463	APR10255	APR10355	APR10455	APR10365	APR10465
	APR3255	APR3355	APR3455	APR3365	APR3465	APR6255	APR6355	APR6455	APR6365	APR6465	APR10257	APR10357	APR10457	APR10367	APR10467
				NPR3363	NPR3463				NPR6364	NPR6464				NPR10366	NPR10466
				NPR3364	NPR3464				NPR6365	NPR6465				NPR10367	NPR10467
Receptacles	AR321	AR331	AR341	AR332	AR342	AR621	AR631	AR641	AR632	AR642	AR1021	AR1031	AR1041	AR1032	AR1042
	AR323	AR333	AR343	AR334	AR344	AR623	AR633	AR643	AR634	AR644	AR1023	AR1033	AR1043	AR1034	AR1044
	AR327	AR337	AR347	AR338	AR348	AR627	AR637	AR647	AR638	AR648	AR1027	AR1037	AR1047	AR1038	AR1048
				NR332	NR342				NR632	NR642				NR1032	NR1042

Any plug will fit and operate in any receptacle or cord connector in that same column.

WARNING

Use cable with diameters within the specified range given in TABLE "B" for any given grommet size and clamp orientation. Failure to do so may result in over stressed wire terminations which could cause the conductors to pull out of the contacts and cause serious/fatal injuries due to electrocution.

ACP Plugs for EBR, EBRH, JBR, MD2SR and DBR Receptacles

ACP Plugs can be used with ACR and ADR series receptacles and ARC cord connectors. ACP Plugs can also be used with the following receptacles in hazardous locations.

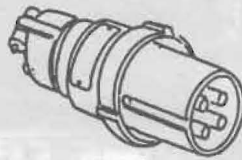

PLUG	RECEPTACLE				
ACP3023BC	DBR	EBR	EBRH	JBR	MD2SR-3023
ACP3034BC	DBR	EBR	EBRH	JBR	MD2SR-3034
ACP6023BC	DBR	EBR	EBRH	JBR	MD2SR-6023
ACP6034BC	DBR	EBR	EBRH	JBR	MD2SR-6034
ACP1023CD	DBR	EBR	EBRH	JBR	MD2SR-1023
ACP1034CD	DBR	EBR	EBRH	JBR	MD2SR-1034
ACP1534CD		EBR			
ACP1534DE		EBR			

Replacement Parts Lists for Powertite "ACP" plugs

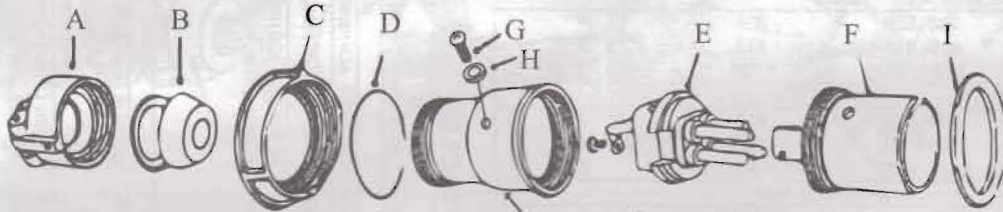

Housing not offered as a replacement part.

Amp	Style	Wires/Poles	Item A Gland Nut Assembly	Item B Bushing Kit	Item C Clamp Ring	Item D Split Ring	Item E Contact Block Assembly	Item F Sleeve STD Position	Item F Sleeve P4 Position	Item G Sleeve Locking Screw	Item H Nylon Washer	Item I Gasket
30	1	2W 2P	69350482000	PTGB30	CLMPR30	-----	API-3022	69304368001	69304368003	69P06174000	69W05146003	69304023016
	1	3W 3P	69350482000	PTGB30	CLMPR30	-----	API-3033	69304368001	69304368003	69P06174000	69W05146003	69304023016
	1	4W 4P	69350482000	PTGB30	CLMPR30	-----	API-3044	69304368001	69304368003	69P06174000	69W05146003	69304023016
	2	2W 3P	69350482000	PTGB30	CLMPR30	-----	API-3023	69304368001	69304368005	69P06174000	69W05146003	69304023016
	2	3W 4P	69350482000	PTGB30	CLMPR30	-----	API-3034	69304368001	69304368005	69P06174000	69W05146003	69304023016
60	1	2W 2P	69350482000	PTGB60	CLMPR23P60	-----	API-6022	69304339001	69304339003	69P06175000	69W05146001	69304023017
	1	3W 3P	69350482000	PTGB60	CLMPR23P60	-----	API-6033	69304339001	69304339003	69P06175000	69W05146001	69304023017
	1	4W 4P	69350482000	PTGB60	CLMPR4P60	-----	API-6044	69304340001	69304340003	69P06175000	69W05146001	69304023018
	2	2W 3P	69350482000	PTGB60	CLMPR23P60	-----	API-6023	69304339002	69304339005	69P06175000	69W05146001	69304023017
	2	3W 4P	69350482000	PTGB60	CLMPR4P60	-----	API-6034	69304340002	69304340005	69P06175000	69W05146001	69304023018
100	1	2W 2P	69350495000	PTGBCD	CLMPR23P100	69304113001	API-1022	69304341001	69304341003	69P06175000	69W05146001	69304023019
	1	3W 3P	69350495000	PTGBCD	CLMPR23P100	69304113001	API-1033	69304341001	69304341003	69P06175000	69W05146001	69304023019
	1	4W 4P	69350495000	PTGBCD	CLMPR4P100	69304113001	API-1044	69304342001	69304342003	69P06175000	69W05146001	69304023020
	2	2W 3P	69350495000	PTGBCD	CLMPR23P100	69304113001	API-1023	69304341002	69304341005	69P06175000	69W05146001	69304023019
150(CD)	2	3W 4P	69350495000	PTGBCD	CLMPR4P100	69304113002	API-1034	69304342002	69304342005	69P06175000	69W05146001	69304023020
150(DE)	2	3W 4P	69350495001	PTGBDE	CLMPR4P100	69304113002	API-15034	69304342006	69304342005	69P06175000	69W05146001	69304023020

Replacement Parts Lists for Powertite "ARC" Cable Connectors

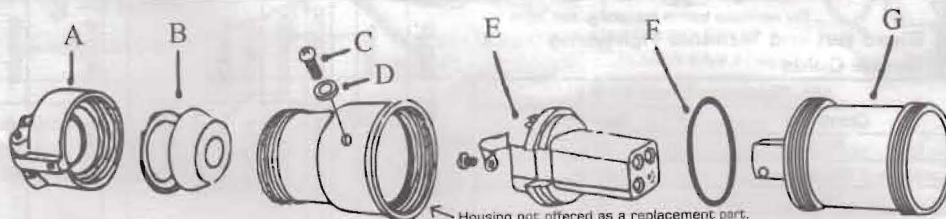

Housing not offered as a replacement part.

Amp	Style	Wires/Poles	Item A Gland Nut Assembly	Item B Bushing Kit	Item C Sleeve Locking Screw	Item D Nylon Washer	Item E Contact Block Assembly	Item F O-Ring	Item G Sleeve Std Position	Item G Sleeve P4 Position
30	1	2W 2P	69350482000	PTGB30	69P06988000	69W05469012	ARI-3022	69304374003	69351039001	69351039005
	1	3W 3P	69350482000	PTGB30	69P06988000	69W05469012	ARI-3033	69304374003	69351039001	69351039005
	1	4W 4P	69350482000	PTGB30	69P06988000	69W05469012	ARI-3044	69304374003	69351039001	69351039005
	2	2W 3P	69350482000	PTGB30	69P06988000	69W05469012	ARI-3023	69304374003	69351039001	69351039005
	2	3W 4P	69350482000	PTGB30	69P06988000	69W05469012	ARI-3034	69304374003	69351039001	69351039005
60	1	2W 2P	69350482000	PTGB60	69P06988000	69W05469012	ARI-6022	69304374001	69351038001	69351038005
	1	3W 3P	69350482000	PTGB60	69P06988000	69W05469012	ARI-6033	69304374001	69351038001	69351038005
	1	4W 4P	69350482000	PTGB60	69P06988000	69W05469012	ARI-6044	69304374001	69351038001	69351038005
	2	2W 3P	69350482000	PTGB60	69P06988000	69W05469012	ARI-6023	69304374001	69351038001	69351038005
	2	3W 4P	69350482000	PTGB60	69P06988000	69W05469012	ARI-6034	69304374001	69351038001	69351038005
100	1	2W 2P	69350495000	PTGBCD	69P06175000	69W05146001	ARI-1022	69304374004	69351039001	69351039005
	1	3W 3P	69350495000	PTGBCD	69P06175000	69W05146001	ARI-1033	69304374004	69351039001	69351039005
	1	4W 4P	69350495000	PTGBCD	69P06175000	69W05146001	ARI-1044	69304374004	69351039001	69351039005
	2	2W 3P	69350495000	PTGBCD	69P06175000	69W05146001	ARI-1023	69304374004	69351039001	69351039005
150(CD)	2	3W 4P	69350495000	PTGBCD	69P06175000	69W05146001	ARI-15034	69304374004	69351039009	69351039005
150(DE)	2	3W 4P	69350495001	PTGBDE	69P06175000	69W05146001	ARI-15034	69304374004	69351039009	-----

Replacement Parts Lists for Powertite "ADR" Receptacles

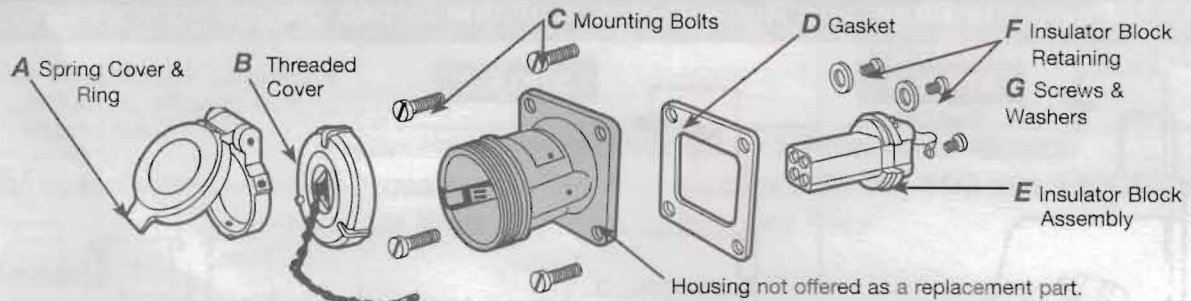

Ampacity	Style	Description	Item A Spring Cover & Ring	Item B Threaded Cover	Item C Mounting Bolts	Item D Gasket	Item E Contact Block Assembly	Item F Insulator Block Retaining Screws	Item G Washers
30	1	2W 2P	PTSC30	PTTC30	69P05340000	69060871000	ARI-3022	69P05738000	69W05127000
	1	3W 3P	PTSC30	PTTC30	69P05340000	69060871000	ARI-3033	69P05738000	69W05127000
	1	4W 4P	PTSC30	PTTC30	69P05340000	69060871000	ARI-3044	69P05738000	69W05127000
	2	2W 3P	PTSC30	PTTC30	69P05340000	69060871000	ARI-3023	69P05738000	69W05127000
	2	3W 4P	PTSC30	PTTC30	69P05340000	69060871000	ARI-3034	69P05738000	69W05127000
60	1	2W 2P	PTSC60A	PTTC60A	69P07311000	69060567000	ARI-6022	69P05738000	69W05127000
	1	3W 3P	PTSC60A	PTTC60A	69P07311000	69060567000	ARI-6033	69P05738000	69W05127000
	1	4W 4P	PTSC60B	PTTC60B	69P07311000	69060567000	ARI-6044	69P05738000	69W05127000
	2	2W 3P	PTSC60A	PTTC60A	69P07311000	69060567000	ARI-6023	69P05738000	69W05127000
	2	3W 4P	PTSC60B	PTTC60B	69P07311000	69060567000	ARI-6034	69P05738000	69W05127000
100	1	2W 2P	PTSC100A	PTTC100A	69P07311000	69060567000	ARI-1022	69P05738000	69W05127000
	1	3W 3P	PTSC100A	PTTC100A	69P07311000	69060567000	ARI-1033	69P05738000	69W05127000
	1	4W 4P	PTSC100B	PTTC100B	69P07311000	69060567000	ARI-1044	69P05738000	69W05127000
	2	2W 3P	PTSC100A	PTTC100A	69P07311000	69060567000	ARI-1023	69P05738000	69W05127000
	2	3W 4P	PTSC100B	PTTC100B	69P07311000	69060567000	ARI-1034	69P05738000	69W05127000
150	2	3W4P	PTSC100B	PTTC100B	69P07311000	69060567000	ARI-15034	69P05738000	69W05127000

Maintenance

Electrical and mechanical inspection of all components must be performed regularly. It is recommended that inspection be performed a minimum of once a year.

WARNING

If any parts of the plug, receptacle or cable connector appear to be missing, broken or show signs of damage:

DISCONTINUE USE IMMEDIATELY!

This condition could cause serious/fatal personal injury due to electrocution and/or equipment damage. Repair with proper replacement part(s) before continuing service.

1. Inspect all contact wire terminals for tightness. (Retorque). Discoloration due to excessive heat is an indicator of possible problems and should be thoroughly investigated and repaired as necessary.
2. Check grounding and bonding for correct installation and secure connection. (Re-torque)
3. Check gaskets for deterioration and replace if necessary.
4. Clean exterior surfaces making sure nameplates remain legible.

5. Inspect gland nut and cable grip tightness to ensure proper cord/cable gripping.
6. Torque all screws as described in instructions before re-using device.
7. Inspect housing parts and replace those which are broken or excessively worn.
8. Check contacts for signs of excessive arcing or burning and replace if necessary.

In addition to these required maintenance procedures, we recommend an Electrical Preventive Maintenance program as described in the National Fire Protection Association Bulletin NFPA No. 70B.

ELECTRICAL RATING

Maximum Voltages: 600 VAC @ 50-400Hz, 250V DC; Maximum continuous current: 30, 60, 100 or 150 Amperes.

Retain this Instruction Sheet for Future Reference

Powertite Plugs and Receptacles available in two grounding styles:

STYLE 1

Shell Only Grounding

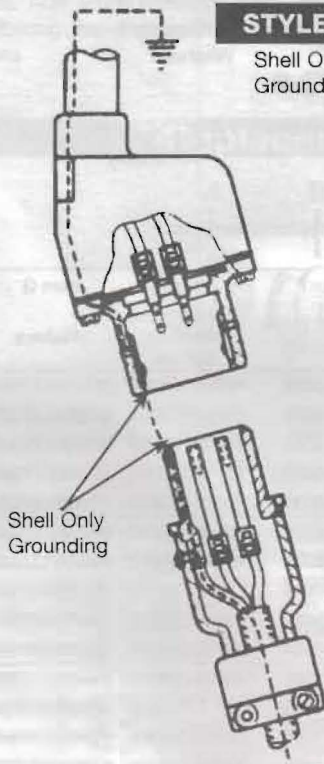

STYLE 2

Extra Pole Grounding

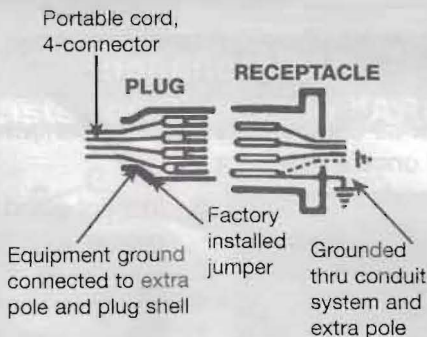
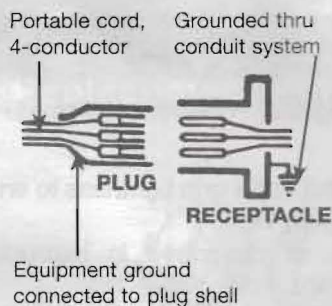
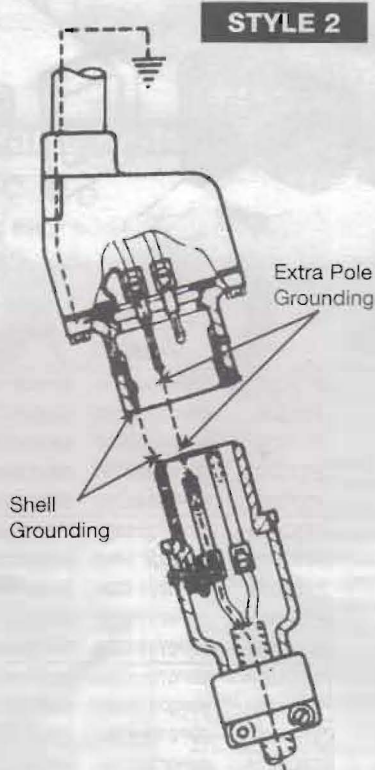

PLUG - Equipment grounding conductor is wired directly to a solderless lug which is connected to the plug housing with pressure connector. All contacts are "current carrying".

RECEPTACLE - Two detent spring clips engage the grounded plug housing on plug insertion - grounded plug shell makes contact with receptacle ground spring before line and load poles are engaged. Grounding path is maintained until after current-carrying contacts disengage. All contacts are "current carrying".

PLUG - Equipment grounding conductor is not only connected to the solderless lug in the plug housing, but also to an extra grounding pole. Grounding pole has copper alloy grounding jumper strap that connects to plug housing.

RECEPTACLE - Two detent spring clips engage the grounded plug housing on plug insertion. Jumper from extra grounding pole is electrically connected to a screw on receptacle housing. Longer grounding pole "makes first and breaks last".

PowerTite 30, 60, 100 Amp Pin and Sleeve Receptacles, Plugs and Connectors

Dimensions in Inches

Receptacle Mounted on AEE Box

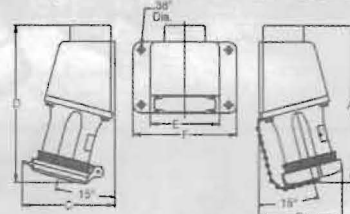

Amp	A	B	C	D	E	F
30	6.88	3.75	4.25	7.13	3.88	5.00
60	9.75	5.25	5.50	10.00	4.25	6.38

Receptacle Mounted on AJA-AJAC Box

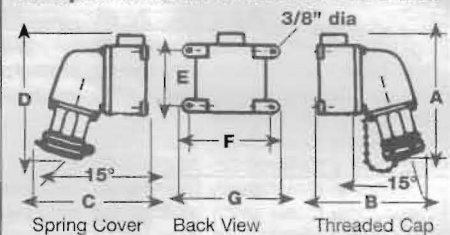

Amp	A	B	C	D	E	F	G
60	9.63	8.00	8.81	10.69	4.88	6.88	7.88
100	11.44	9.00	9.19	11.82	4.88	6.88	7.88

Receptacle

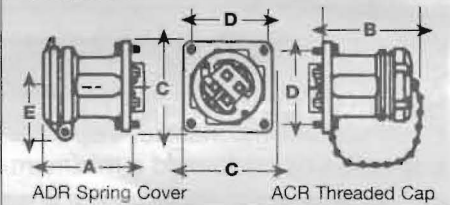

Amp	No. of Poles	A	B	C	D	E
30	2, 3, 4	3.31	3.19	3.38	2.72	2.06
60	2, 3	4.88	4.63	4.50	3.50	2.31
60	4	4.88	4.63	4.50	3.50	2.44
100	2, 3	5.81	5.50	4.50	3.50	2.44
100	4	5.81	5.50	4.25	3.50	2.56
150	4	5.81	5.50	4.25	3.50	2.56

Connector

Amp	A	B
30	10.50	3.13
60	13.25	3.81
100	16.00	4.25

Plug

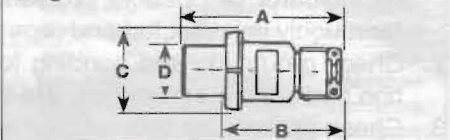

Amp	No. of Poles	A	B	C	D
30	2, 3, 4	6.00	4.75	3.13	1.86
60	2, 3	7.81	4.94	3.50	2.23
60	4	7.81	4.94	3.81	2.55
100	2, 3	10.50	6.63	4.00	2.47
100 & 150(CD)	4	10.50	6.63	4.25	2.72
150(DE)	4	13.40	9.73	4.25	2.72