

Explosion Proof Handlamp Plug Upgrade Instruction Manual

Do not attempt operation until you are familiar with all warnings, precautions, and procedures outlined within this instruction sheet. Read carefully before operating. Retain these instructions for future reference.

WARNING:

USER SHOULD BE TRAINED IN THE PROPER USE AND MAINTENANCE OF THIS DEVICE.
IMPROPER USE OF THIS PLUG CAN LEAD TO SERIOUS INJURIES OR DEATH TO PERSONNEL.

PERIODIC INSPECTION OF THE PLUG IS NECESSARY.

PLUG MUST BE ROUTINELY CHECKED FOR BREAKS, OR ANY SEVERE ABRASIONS, AND IF ANY ARE FOUND, THE UNIT MUST BE REPLACED BEFORE RESUMING USE.

OPERATIONAL DATA

1. Lift receptacle door and insert plug all the way into the receptacle.
2. Turn plug to clockwise limit (45°). This closes internal contacts and completes circuit.
3. Release plug. Plug will move outward to "LOCK" position. Check by trying to turn plug without pushing inward; plug should not turn.
4. To remove plug, push plug inward and turn to counterclockwise limit (45°). Pull plug straight out.

MAINTENANCE

These plugs require no maintenance other than periodic cleaning and a check for damage and/or loose fasteners. Also, check cord for damage and/or wear. This should be performed on a regular basis, determined by the environment and usage.

WARNING: Disconnect and Lock Out supply circuit before starting maintenance work.

1. To clean plug, it is recommended that a soft, nonmetallic bristle brush be used.
2. Check tightness of all accessible screws.
3. Inspect the entire assembly (including cord) for damage and/or wear. Contact Larson Electronics for availability of replacement parts and discontinue use of the equipment until repairs are made.

Unauthorized modification may impair the function and/or safety of the work light and could affect the life of the equipment. Always check damaged or worn out parts before using the work light. When work light is not in use, store it in a secure place out of the reach of children. Inspect for good working condition prior to storage and before re-use.

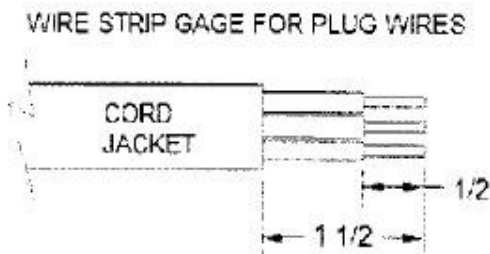
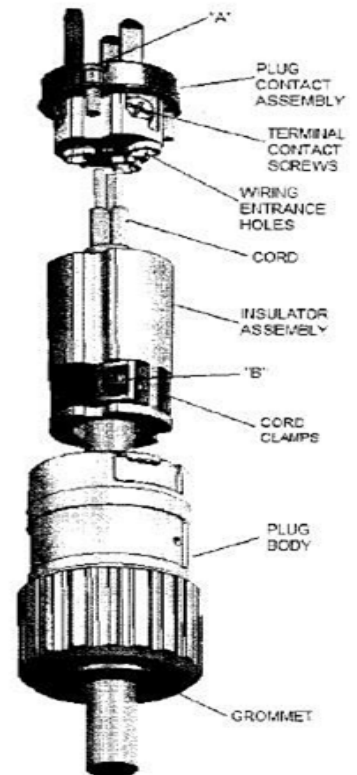

Should further information not covered by these instructions be required, please contact Larson Electronics at 1-800-369-6671 or sales@larsonelectronics.com for further assistance.

Please visit LarsonElectronics.com for **Warranty** and **Return** information.