

Explosion Proof Push Button Stop/Start Switch C1D1, C2D1 - Pilot Light Instruction Manual

CAUTION: Before installing, make sure you are compliant with area classifications, failure to do so may result in bodily injury, death and property damage. Do not attempt installation until you are familiar with all applicable Electrical Codes. Make sure that the circuit is De-energized before starting installation or maintenance. Verify that the installation is grounded. Failure to ground will create electrical shock hazards, which can cause serious injury and/or death.

IMPORTANT: Please read these instructions carefully before installing or maintaining this equipment. Good electrical practices should be followed at all times and this data should be used as a guide only.

INSTALLATION

1. Mount the back box by means of mounting lugs. Install conduit nipple and sealing fittings, to be installed on each conduit entrance or exit to the enclosure back box in Class I and Class II areas. Thread conduit into sealing fitting (Note: For Class I areas, the conduit should engage [5] full threads.)
2. Remove 4 screws to free front cover. Loosen the 2 smaller screws to remove the switch plate.
3. The conduit threads should be lubricated with a non-electrical insulating lubricant or pipe joint compound that will not promote corrosion or chemically attack aluminum.
4. After conduit system has been properly installed, pull the wires and make electrical connections as required. The electrical circuits and ground continuity should be checked with an instrument approved for the area. Notice: Connect only copper wire to this device.
5. All conduits entering or leaving the enclosure must be sealed within 18" of the enclosure with listed sealing fittings. Caution must be taken during installation to be sure that the ground flange flame joints of the cover and box are not scratched, nicked, or damaged. Before assembly of the cover to the box, the mating ground surfaces of both the box and cover should be wiped clean to assure that the ground flame joint will be free of all foreign particles such as lint, dust or dirt.
6. After tightly bolting the cover assembly/assemblies to the enclosure, all box to cover flame joints should be checked with a 0.0015" thick feeler gauge such that the gauge will not enter the flame path more than 1/8" at any point.

MAINTENANCE

All moving shafts should be lubricated occasionally to prevent binding. Only use a lubricant which is suitable for use with aluminum or stainless steel. If devices are to be installed in corrosive areas which will attack aluminum alloys containing less than 0.4% copper (boxes and covers) and 303 stainless steel (mostly shafts), the device should be suitably protected from the corrosive material.

CAUTION: To prevent ignition of hazardous atmospheres, disconnect from the supply circuits before opening the enclosure; keep tightly closed while circuits are energized.

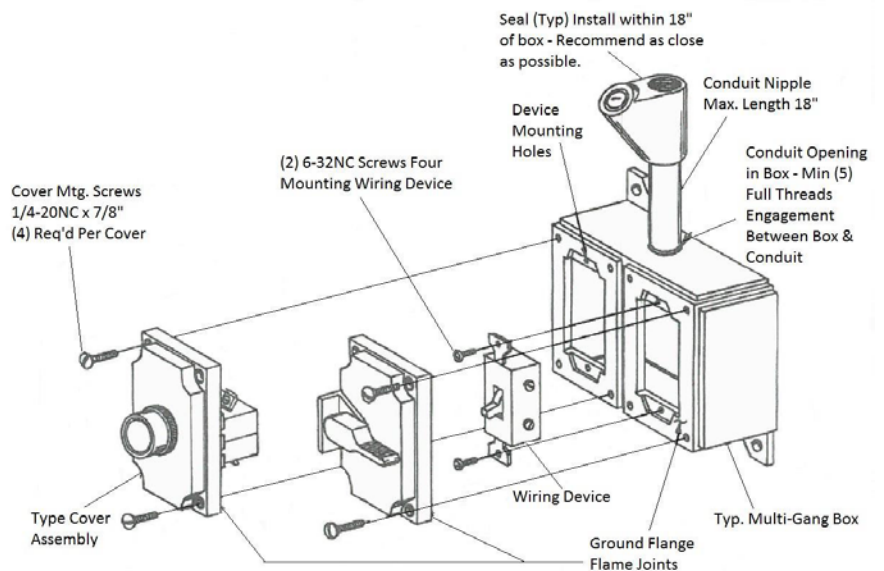

These instructions may not cover all details or variations of this product for your equipment or installation requirements. Should further information not covered by these instructions be required, please contact Larson Electronics at 1-800-369-6671 for further assistance.