

INSTALLATION, OPERATION & MAINTENANCE DATA SHEET

45A Explosion Proof Contactor - C1D1, C2D1 - 3P - (2) 3/4" NPT Hubs, North/South -
ATEX/IECEX Rated

INSTALLATION INSTRUCTIONS

This junction box **must** be installed by trained, qualified and competent personnel. The installation **must** comply with local, state and national regulations, as well as safety practices for this type of equipment.

WARNING: Electrical power must be **OFF** during installation. Disconnect the primary power source and lock out.

The mounting location must be flat and provide proper clearance, rigidity and strength to support the contactor and all contained devices. Securely fasten the contactor to the mounting location using 1/4" or 3/8" diameter (as required) steel mounting bolts and washers, or washer head bolts. Install sealing fitting and conduit using an approved electrical conducting type lubricant on the threads. The conduit thread connections must be tapered pipe thread conforming to ANSI/ASME B1.20.1. A minimum of 5 full threads engagement is required for all conduit connections. Conduit sealing fittings, approved for the specific hazardous location where the contactor is used, must be installed within 18 inches of the contactor. All unused conduit openings must be plugged using a close-up-plug approved for the specific hazardous location where the contactor is used. Plugs must be tightly installed with a minimum engagement of 5 full threads.

IMPORTANT: Install only U.L. listed and CSA certified auxiliary control devices for hazardous locations. Refer to the individual operator installation sheet for installation details. The operator spacing is to be determined from the dimensional chart on the opposite side of this installation sheet.

NOTE: If installing a breather and/or a drain, make certain they are suitable for the specific hazardous location where they are to be used. Also, provide a protective device to shield the breather and drain during hosedown operations. Inspect and clean the machined, threaded surfaces of both the cover and the box. Clean surfaces by wiping with a clean, lint-free cloth. Apply a light coating of lubricant to the cover threads. Install and hand tighten the cover to the box.

NOTE: The Internal Ground Screw provided in this contactor **must** be used for the equipment grounding connection. The external ground (if provided) is provided for use only as a supplemental connection where required (or, permitted) by local codes or authorities. This contactor is for use only with covers having eight full thread engagement and specified on the nameplate.

NOTE: Refer to the wiring diagram for how to make the electrical connection.

MAINTENANCE INSTRUCTIONS

After installation, this junction box should be inspected at regular intervals to ascertain that the cover is tight, that all conduit connections are intact and free of corrosion, and that the contactor mounting bolts are tight and in good condition. If the contactor must be opened for servicing the following procedures must be followed: **WARNING:** Before servicing the contactor, care must be taken to be certain that the electrical power is **OFF**. Disconnect the contactor from the primary power source and lock out. Inspect the threaded flame joint surface. Threads must be free of nicks, dirt or any foreign particle build-up that would prevent a proper seal. Should the threads be damaged, consult the factory. Never attempt to rework threads. Threads must seat fully against each other to provide explosion-proof joint. Apply lubricant to cover threads before re-installing the cover. An improper flame joint can result in an explosion, creating a potential for physical injury and property damage.

Technical information, advice and recommendations contained in these documents are based upon information that Larson Electronics believes to be reliable. All the information and advice contained in these documents is intended only for use by persons having been trained, and possessing the requisite skill and know-how, and to be used by such persons only at their own discretion and risk. The nature of these instructions is informative only and does not cover all of the details, variations or combinations in which this equipment may be used; its storage, delivery, installation, check-out, safe operation and maintenance. Since conditions of use of the product are outside of the care, custody and control of Larson Electronics, the purchaser should determine the suitability of the product for his intended use, and assumes all risk and liability whatsoever in connection therewith.

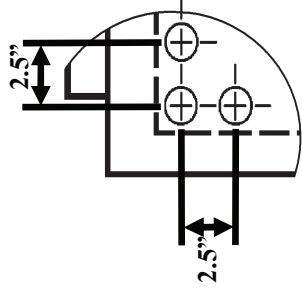
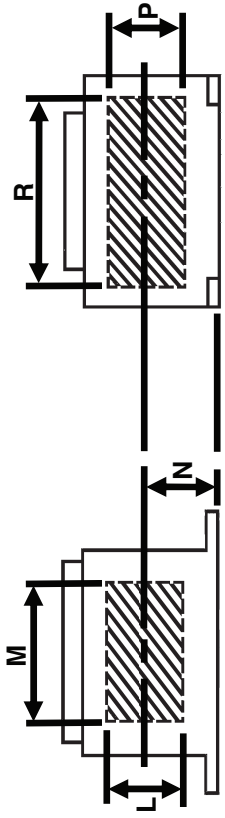

The side walls of enclosures can be drilled and tapped for the installation of auxiliary control devices. The maximum number of openings allowed per side wall and the maximum total allowed for a specific contactor are as shown in the chart below.

To maintain Group "B" suitability openings must have 7 full threads of engagement with the installed auxiliary device.

To maintain Group "C" & "D" suitability openings must have 5 full threads of engagement with the installed auxiliary device.

CATALOG NUMBER	L SHORT WALL HEIGHT	M SHORT WALL LENGTH	N CENTER-LINE OF CONDUIT	P LONG WALL LENGTH	R LONG WALL LENGTH	SHORT SIDE (ROWS X COLUMNS)	LONG SIDE (ROWS X COLUMNS)	MAXIMUM NUMBER OF OPENINGS PER LONG SIDE WALL	MAXIMUM NUMBER OF OPENINGS PER SHORT SIDE WALL	MAXIMUM NUMBER OF TOTAL OPENINGS PER CONTACTOR
EPL-AEC	$3\frac{5}{16}$ "	$4\frac{5}{8}$ "	$2\frac{1}{8}$ "	$3\frac{5}{16}$ "	$5\frac{3}{4}$ "	2 X 2	2 X 2	4	4	8

INSTRUCTIONAL DATA SHEET

FOR DRILLING & TAPPING OF CONDUIT OPENINGS IN U.L. LISTED, CSA CERTIFIED, CAST ALUMINUM BOXES WITH THREADED JOINTS, FOR HAZARDOUS LOCATIONS

GENERAL INSTRUCTIONS & REQUIREMENTS FOR DRILLING & TAPPING IN FIELD.

NOTE: The following requirements must be met in order to comply with U.L. #886 standards and/or the National Electrical Code and maintain the U.L. Listing / Classification and CSA certification of the contactor.

- 1.) Standard NPT threads (with a 3/4" per foot taper) **must** be used for all conduit openings. After tapping, all NPT conduit openings **must** gage +1/2 to +3-1/2 turns beyond nominal.
- 2.) Field drilling and tapping of the side and back walls of blank boxes may be done, provided the location of conduit openings meets the specifications of Chart 1, and minimum wall thickness meets the dimensions shown on Charts 2 & 3. Use Chart 1 to determine the maximum quantity and size of conduit openings permitted.

CAUTION: If box has ribs, field drilling must **not** interfere with those ribs.

NOTE: 1/2" trade size is the minimum allowable size for any conduit opening. Refer to Chart 4 for maximum allowable conduit sizes.

- 3.) **CLASS I, DIVISION 1 & CLASS II LOCATIONS** require boxes with a wall thickness sufficient to provide a minimum of five (5) full threads. (See Chart 2)

- 4.) **CLASS II LOCATIONS, WHEN THE BOX IS NOT SUPPORTED BY THE CONDUITS** require a wall thickness sufficient to provide a minimum of 3-1/2 full threads. (See Chart 3)
- 5.) After the size of conduit openings has been determined for specific enclosures, measure the wall thickness and refer to the specific chart per the following steps:
 - A.) 5 Full Thread Reference Chart 2.
 - B.) 3-1/2 Full Thread Reference Chart 3.
- 6.) If insufficient wall thickness is encountered, consult the factory.

INSTALLATION PRECAUTIONS

- 1.) Before installing cover, clean the threads of the cover and the box with a stiff bristle (or wire) brush to remove dirt particles and fillings. Then apply a thin coating of lubricant to the threads and install the cover tightly.

CAUTION: To prevent ignition of Hazardous Atmospheres, Disconnect from the Supply Circuit Before Opening contactor . Keep Tightly Closed when Circuits are Alive.

**REMEMBER TO SAVE ONE OF THESE SHEETS
FOR MAINTENANCE PERSONNEL.**

MAXIMUM CONDUIT SIZE: 2"

Chart 1: Minimum Centers for Drilled & Tapped Openings for Conduits.
(Allows for locknut, bushing & union clearance)

SIZE	FORM	1/2	3/4	1	1 1/4	1 1/2	2	2 1/2	3	3 1/2	4
1/2	(1) MIN	1 3/16									
	(2) PRE	1 3/8									
	(3) GU	1 5/8									
3/4	(1) MIN	1 3/8	1 1/2								
	(2) PRE	1 1/2	1 5/8								
	(3) GU	1 3/4	1 13/16								
1	(1) MIN	1 1/2	1 3/4	1 13/16							
	(2) PRE	1 3/4	1 7/8	2							
	(3) GU	1 7/8	2	2 1/8							
1 1/4	(1) MIN	1 11/16	1 15/16	2 1/16	2 5/16						
	(2) PRE	1 15/16	2 1/16	2 1/4	2 1/2						
	(3) GU	2 1/16	2 1/4	2 5/16	2 1/2						
1 1/2	(1) MIN	1 15/16	2 1/16	2 3/16	2 1/2	2 5/16					
	(2) PRE	2 1/16	2 1/4	2 3/8	2 5/8	2 3/4					
	(3) GU	2 3/16	2 9/32	2 7/16	2 5/8	2 3/4					
2	(1) MIN	2 1/4	2 3/8	2 9/16	2 13/16	2 15/16	3 3/16				
	(2) PRE	2 3/8	2 1/2	2 3/4	3	3 1/8	3 3/8				
	(3) GU	2 1/2	2 19/32	2 3/4	3	3 1/8	3 3/8				
2 1/2	(1) MIN	2 7/16	2 9/16	2 3/4	3	3 1/8	3 3/8	3 5/8			
	(2) PRE	2 5/8	2 3/4	3	3 3/4	3 3/8	3 5/8	4			
	(3) GU	3 1/8	3 7/32	3 3/8	3 9/16	3 11/16	4	4 5/8			
3	(1) MIN	2 13/16	2 15/16	3 1/16	3 5/16	3 7/16	3 3/4	4	4 5/16		
	(2) PRE	3	3 1/8	3 3/8	3 5/8	3 3/4	4	4 3/8	4 3/4		
	(3) GU	3 9/16	3 21/32	3 13/16	4	4 1/8	4 7/16	5 1/16	5 1/2		
3 1/2	(1) MIN	3 1/8	3 3/4	3 3/8	3 5/8	3 3/4	4 1/16	4 5/16	4 5/8	4 15/16	
	(2) PRE	3 3/8	3 1/2	3 5/8	3 7/8	4	4 3/8	4 5/8	5	5 5/8	
4	(1) MIN	3 7/16	3 9/16	3 11/16	3 15/16	4 1/16	4 3/8	4 5/8	4 15/16	5 1/4	5 9/16
	(2) PRE	3 3/4	3 7/8	4	4 1/4	4 3/8	4 3/4	5	5 3/4	5 5/8	6
Approx. O.D. of:	LOCKNUT	1 1/4	1 1/8	1 11/16	2 1/16	2 1/16	3	3 7/16	4 3/16	4 13/16	5 3/8
	BUSHING	1	1 1/4	1 1/2	1 15/16	2 13/64	2 5/8	3 7/32	3 7/8	4 7/16	5
	CONDUIT	7/8	1 1/16	1 3/8	1 11/16	1 15/16	2 3/8	2 7/8	3 1/2	4	4 1/2

- (1) Minimum spacing required to provide clearance over locknuts and bushings.
- (2) Preferred - More liberal spacings between centers of conduits to be used whenever possible.
- (3) GU - When Listed "GU" series unions (1/2" thru 3") are used, additional spacing between conduits will be required, as specified above.

Conduit Size	1/2	3/4	1	1 1/4	1 1/2	2	2 1/2	3	3 1/2	4
Dim. "A" *	1	1	1 1/8	1 3/8	1 1/2	1 3/4	2 1/8	2 1/2	2 7/8	3 1/8

* Note: If Listed "GU" series unions are being used (1/2" thru 3"), additional space for clearance may be required. Check dimensions of fittings being used.

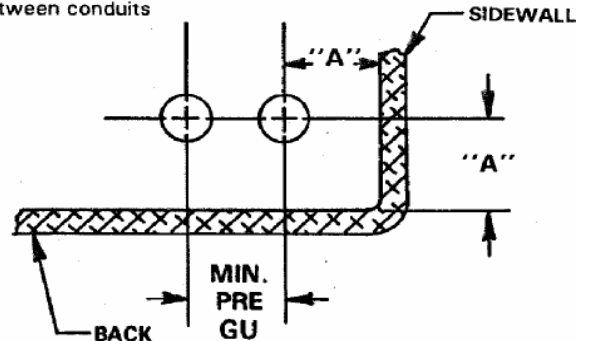

Chart 2: Required wall thickness for five (5) full threads engagement per U.L. 886 Standards.

Class I, Division I
Class II Supported by Conduit

CONDUIT SIZE	MINIMUM NUMBER OF FULL THREADS	MINIMUM WALL THICKNESS
½" & ¾"-14	5 (1)	29/64"
1", 1¼", 1½" & 2"-11½	5 (1)	7/16"
2½", 3", 3½" & 4"-8	5 (1)	5/8"

(1) A box used may have thicker walls than required. For thicker walled boxes, the inner end of each conduit opening shall be smooth and well-rounded, as shown below.

Chart 3: Required wall thickness for 3-1/2 full threads engagement.

Class II Locations Not Supported by Conduit

CONDUIT SIZE	MINIMUM NUMBER OF FULL THREADS	MINIMUM WALL THICKNESS
½" & ¾"-14	3½ (1)	¼"
1", 1¼", 1½" & 2"-11½	3½ (1)	5/16"
2½", 3", 3½" & 4"-8	3½ (1)	7/16"

(1) Same as shown for Chart 2.

NOTE:

- 1) Conduit openings must be tapped to a depth which allows the conduit to be fully engaged.
- 2) Do not over-tap conduit openings; the conduit must tighten fully without bottoming-out on the unthreaded area of the conduit.
- 3) Conduit opening gaging requirement: "+1/2 to +3-1/2 turns deeper than nominal".

RECOMMENDED TAP DRILL

TAPPED HOLE SIZE - NPT	TAP DRILL SIZE (DIA.)
1/2" - 14 3/4" - 14	23/32" 59/64"
1" - 11-1/2 1-1/4" - 11-1/2 1-1/2" - 11-1/2 2" - 11-1/2	1-5/32" 1-1/2" 1-47/64" 2-7/32"
2-1/2" - 8 3" - 8 3-1/2" - 8 4" - 8	2-5/8" 3-1/4" 3-3/4" 4-1/4"

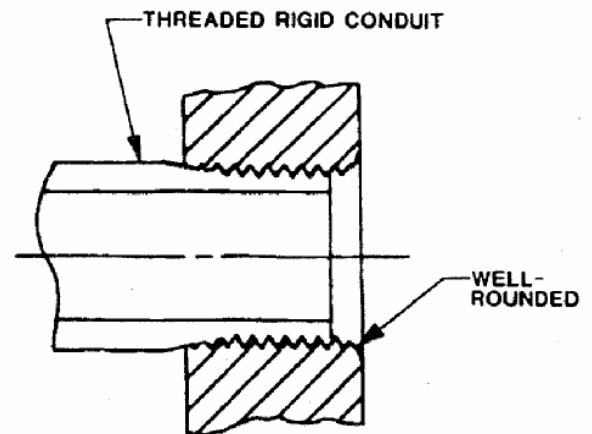

CONDUIT OPENING WITHOUT CONDUIT STOP