

1 DESCRIPTION



2 SPECIFICATIONS

DESCRIPTION	SPECIFICATION
Technology:	microwave doppler radar
Transmitter frequency:	24.150 GHz
Transmitter radiated power:	< 20 dBm EIRP
Transmitter power density:	< 5 mW/cm ²
Mounting height:	11.5 - 25 ft
Detection zone:	13 x 16 ft @ 16ft
Minimum detection speed:	2 in/s*
Supply voltage:	12V to 24V AC ±10%; 12V to 24V DC +30% / -10%
Mains frequency:	50 to 60 Hz
Power consumption:	< 2 W
Output: - Max. contact voltage: - Max. contact current: - Max. switching power:	relay (free of potential change-over contact) 42V AC/DC 1A (resistive) 30W (DC) / 60VA (AC)
Temperature range:	from -22 °F to + 140 °F
Housing certification	(Adalet / Scott Fetzer Co., UL Listing # E81696) UL Class I, Group B,C,D; UL Class II, Group E,F, G; UL Class III CENELEC: EExd IIC, IP66; NEMA 4x, 7BCD, 9EFG
Dimensions:	9 in (D) x 7 ½ in (W) x 5 ½ in (H)
Materials:	Copper-free aluminum (Housing); Aluminum (Bracket)
Tilt adjustment angle:	- 90° to + 30° in elevation
Weight:	10 lbs
Cable length:	30 ft (10m)
Cable diameter:	1/4 in (6.5 mm) (maximum)
Electrical access:	3/4" NPT pipe thread
Norm conformity	R&TTE 1999/5/EC; EMC 2004/108/EC

Specifications are subject to changes without prior notice. * Measured in optimal conditions

3 INSTALLATION TIPS



- The sensor must be firmly fastened in order not to vibrate.
- The sensor must not be placed directly behind a panel or any kind of material.
- The sensor must not have any object likely to move or vibrate in its sensing field.
- The sensor must not have any fluorescent lighting in its sensing field.

4 WIRING/ HOUSING OPENING AND CLOSING

RED	12-24 V	Connect the wires to the door controller. Choose between NO and NC contact.
BLACK	AC-DC	
WHITE	COM	
GREEN	NO	
YELLOW	NC	

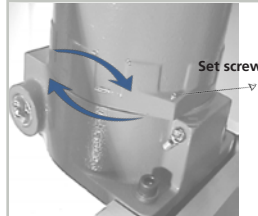

NOTE: Normally, opening the sensor is not necessary, unless access to the manual pushbuttons is required.

- Using a hex key loosen or tighten the setscrew located on the side of the housing.
- Unscrew/ Screw the housing cover.

5 MOUNTING ADJUSTMENT

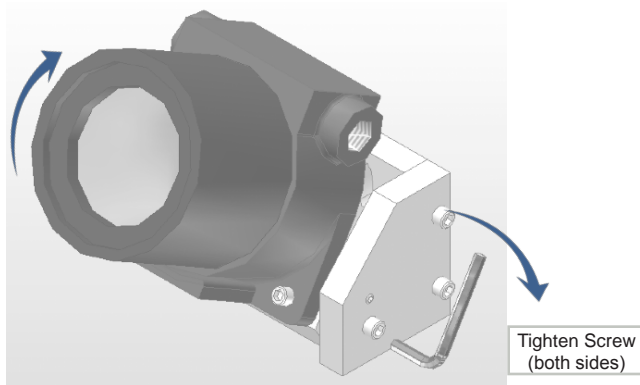

Maximum angle (+30° above horizon)

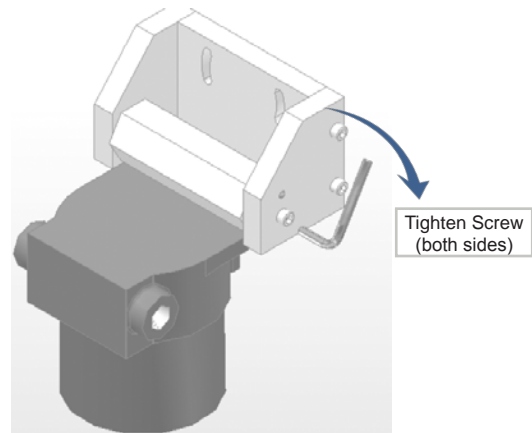

Minimum angle (-90° below horizon)

1. Bolt the bracket securely to the wall or other rigid surface.
2. Make sure that the two 5/16 - 18 Allen head bolts are loose so that the sensor can rotate freely.
3. Rotate the sensor to the appropriate angle for the application. When the bracket rotates, it will click. Every click represents a 7 1/2 angle adjustment.
4. Lock the angle adjustment by tightening the two 5/16 - 18 Allen head bolts.
5. Horizontal angle adjustments can be made by loosening the mounting bolts on the base and twisting to the desired angle.

6 DETECTION FIELD DIMENSIONS

EXP-MS-30W-N4X
Mounting height: 16 ft

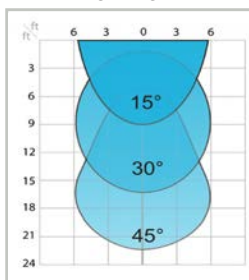

7 POSSIBLE SETTINGS BY REMOTE CONTROL

CHECKING A VALUE

Red Red ? Green
X = number of flashes = value of parameter

FIELD SIZE		XXS	XS	S	>	>	>	>	L	XL	XXL
RELAY HOLD TIME		0.5 s	1 s	2 s	3 s	4 s	5 s	6 s	7 s	8 s	9 s
OUTPUT CONFIGURATION			A	P							
DETECTION MODE			bi	uni	uni AWAY						
DETECTION FILTER			1	2	3	4	5	6			

A = active output (relay active when detection)
P = passive output (relay active when no detection)

bi = two-way detection
uni = one-way detection towards sensor
uni AWAY = one-way detection away from sensor

FACTORY VALUES RESETTING TO FACTORY VALUES:

DETECTION FILTER (REJECTION MODE)



Choose the right detection filter for your application with the remote control

Detection of all targets
(pedestrians and parallel traffic are detected)

1-6

1 = no specific filter

2 = filter against disturbances
(recommended in case of vibrations, rain etc.)

Detection only of vehicles moving*
(pedestrians and parallel traffic are not detected + disturbances are filtered)

Value recommendations according to angle and height:

	23 ft - 11.5 ft	8 ft	
-75°	3	3	Always check if the chosen value is optimal for the application. The object size and nature can influence the detection.
-60°	4	4	
-45°	5	4	

* The vehicle detection filter increases the response time of the sensor.

LED SIGNALS

- When the power is turned ON, the red and green LEDs flash for few seconds.
- During a detection the red LED lights illuminates.
- During configuration, the red LED flashes a number of times corresponding to the parameter being changed (see next table). The green LED flashes a number corresponding to its setting.

8 POSSIBLE SETTINGS BY PUSH BUTTONS

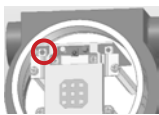

TO START OR END AN ADJUSTMENT SESSION, press and hold either push button until the LED flashes or stops flashing.

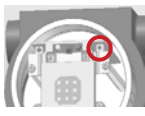

TO SCROLL THROUGH THE PARAMETERS, press the right push button.



TO CHANGE THE VALUE OF THE CHOSEN PARAMETER, press the left push button.

	Parameter number	Value (factory values)
1 FIELD SIZE		(7)
2 HOLD-OPEN TIME		(0)
3 OUTPUT CONFIGURATION		(1)
4 DETECTION MODE		(2)
5 DETECTION FILTER		(1)



TO RESET TO FACTORY VALUES, press and hold both push buttons until both LEDs flash.

9 ACCESS CODE

The access code (1 to 4 digits) is recommended to set sensors installed close to each other.

SAVING AN ACCESS CODE:



Once you have saved an access code, you always need to enter this code to unlock the sensor.

DELETING AN ACCESS CODE:



ERASE AN UNKNOWN ACCESS CODE:

If you do not know the access code, **cut and restore the power supply**. During 1 minute, you can erase an unknown access code:



10 TROUBLESHOOTING

	Sensor appears unresponsive	The sensor power is off.	1 Check the wiring and the power supply.
	Discrepancy between sensor state and sensor output	Improper output configuration on the sensor.	1 Check the output configuration setting on each sensor connected to the user equipment.
	The sensor cycles in and out of detection	The sensor is disturbed by vibration, a moving object, or electrical noise from nearby environment.	1 Make sure the sensor is fixed properly. 2 Make sure the detection mode is unidirectional. 3 Increase the tilt angle. 4 Increase the detection filter value. 5 Reduce the field size.
	The sensor goes into detection for no apparent reason	The sensor detects raindrops or vibrations.	1 Make sure the detection mode is unidirectional. 2 Increase the detection filter value.
	The sensor goes into detection for no apparent reason	In highly reflective environments, the sensor detects objects outside of its detection field.	1 Change the antenna angle. 2 Decrease the field size. 3 Increase the detection filter value.
	The LED flashes quickly after unlocking.	The sensor needs an access code to unlock.	1 Enter the right access code. 2 If you do not know the access code, cut the power supply and restore it to access the sensor and change the access code or delete it.
	The sensor does not respond to the remote control	The remote control batteries are weak or improperly installed.	1 Check the batteries and change them if necessary.

SAFETY INSTRUCTIONS



The manufacturer of the end-user equipment is responsible for carrying out a risk assessment and installing the sensor and the end-user equipment in compliance with applicable national and international regulations and standards of the end-user equipment.

Only trained and qualified personnel may install and setup the sensor.

The warranty is void if unauthorized repairs are made or attempted by unauthorized personnel.



Only for EC countries: According the European Guideline 2012/19/EU for Waste Electrical and Electronic Equipment (WEEE)

Customer Service: 1-800-369-6671 | General Questions: Sales@LarsonElectronics.com

