

HAL-32-60W-ITG-LED

CAUTION: Before installing luminaire, make sure luminaire complies with area classifications, failure to do so may result in bodily injury and/or property damage. Do not attempt installation until you are familiar with the following procedures. All installation must comply with the applicable local and/or National Electrical Code and be performed by a qualified electrician.

Make sure that the circuit is de-energized before starting installation or maintenance.

Verify that the luminaire is grounded. Failure to ground will create electrical shock hazards, which can cause serious injury or death.

NOTE: Due to the surge protection provided in the fixture to protect the internal electronics and LEDs, a branch circuit with the LED fixture may false fail a megohmmeter test (sometimes referred to as a megger test). If a megohmmeter test is required, the LED fixture should be removed from the branch circuit.

NOTE: Multiple fluorescent or LED fixtures attached to a single Ground Fault Circuit Interrupter (GFCI) may cause nuisance tripping of the GFCI. Regulatory agencies allow a small amount of leakage current because of the circuitry required to mitigate possible issues with electromagnetic compatibility (reference UL8750 and EN61347). The summation of these leakage currents from multiple fixtures may be enough to trip a GFCI.

NOTE: For Class I, Division 2 / Class II, Division 1 / Class I, Zone 2 Hazardous Locations, use rigid conduit or appropriate cable connectors/glands rated for Class I, Division 2 Groups BCD (or IEC Zone 2 IIC, IEC Zone 21 IIIC) hazardous areas.

INSTALLATION INSTRUCTIONS

- A. Channels are incorporated in the housing for 5/16" or M8 hex bolts or nuts. (See Figure 1)
 1. 5/16" or M8 hex bolts can be slid into channels for direct mounting; or used to attach brackets which include L-brackets, Wall brackets, Ceiling brackets, Beam Clamps, and Suspension Chains, etc.
 2. 5/16" Hex nuts or M8 hex nuts can be slid into channels and used with eyebolts, threaded rod etc.
- B. The End Caps also have provisions for surface or suspension mounting. (See Figure 2)
- C. The "Earthquake Safety Chain Tab" is incorporated into the endcap.

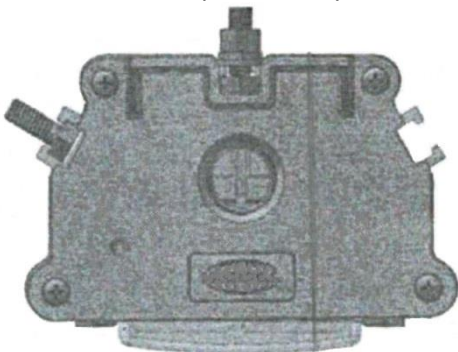

FIGURE 1

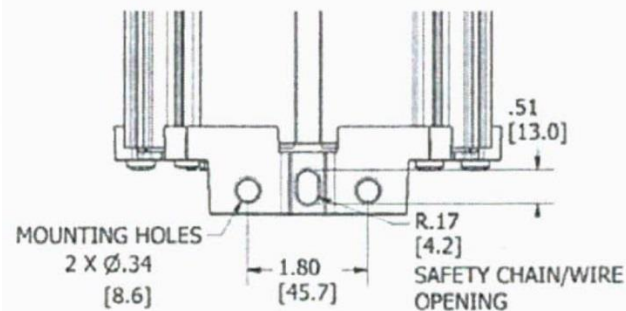

FIGURE 2 (Top View)

IMPORTANT NOTE

Turn off electricity to circuit at main fuse or at circuit breaker.

1. For NEX installation connection to the black (Line), white (Neutral) and green (Ground/Earth) can be made with appropriate wire connectors outside of the fixture, the connectors can be placed in the fixture through the hub. If the terminal blocks are going to be used, loosen and remove the four (4) access plate screws. Remove access plate assembly to allow for entry into fixture.
2. If terminal blocks are used, discard the wires on the entry of the terminal block. Run supply wire to fixture through applicable hub. Make watertight joint using sealing fittings at appropriate hole. The hub in the endcap is for ¼" - 14NPT (or 2 x M20 may be ordered).
3. Pull the supply wires into housing through the conduit hub and connect the appropriate leads using insulated wire nuts or use the terminal blocks present. Fixtures with looping feature may have terminal blocks at both ends of the fixture. See below for wiring battery backup fixtures.
4. Replace access plate screws if necessary.
5. Turn on electricity to verify fixture is operating properly.

Battery Backup Fixtures

The yellow/black wire provided senses a power outage; if there is no current provided to the yellow/black wire, the fixture will operate in battery backup mode. When the yellow/black wire is attached to line voltage and the black wire is switched, the unit will turn off when the switch is open and there is line voltage available. When the yellow/black wire is tied to the black wire and these wires are switched, the fixture will operate in battery backup mode when the switch is open. In both cases where there is no line voltage, the fixture will operate in battery backup mode. Fixtures are shipped with a jumper between the terminals of the black and yellow/black wire. Remove the wire link (jumper) and attach the yellow/black wire to line voltage when local switching is required.

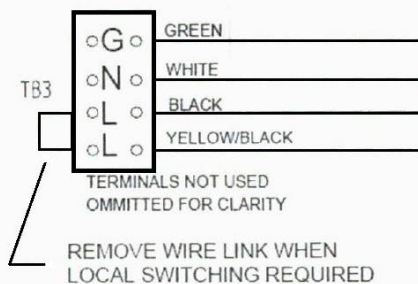

The battery must be charged for at least 24 hours prior to testing. As a routine maintenance, the emergency luminaire should be checked periodically to ensure proper operation. The following schedule is recommended.

1. Visually inspect the charging indicator light monthly. It must be illuminated.
2. Test operation of the circuit at 30 day intervals for a minimum of 30 seconds. The lamp should operate.
3. Conduct a 90 minute discharge test once a year. The lamp should operate for 90 minutes minimum.



Battery changing procedure

1. Remove one end cap from the main housing by removing the four screws that hold the endcap to the housing.
2. Slide the gear tray out of the housing until the battery is exposed. Remove wires from lever nuts as necessary. To remove a wire from a lever nut, fully push up the lever and remove the conductor.
3. Remove the two screws that hold the battery to the gear tray.
4. Unplug the battery from the emergency driver.
5. Reverse the process to complete the battery installation.

NOTE: the fixture is shipped with the battery disconnect cable disconnected. The plugs for the cable are located under the terminal block access plate. Connect these plugs prior to fixture installation. The battery disconnect cable keeps the battery from fully discharging during shipping or storage.

- New fixtures with batteries can be stored for 2 years in an -20°C to 30°C ambient without a need of recharge.
- A fully discharged unit should not be stored more than 6 months without being recharged.
- There is low voltage disconnect of the battery to the emergency drivers, however as the batteries still have self-discharge they should be recharged within 6 months to prevent the cells from permanent capacity loss. For long term storage, separate the battery cable disconnect plugs to prevent the cells from permanent capacity loss.

MAINTENANCE

Disconnect the supplying circuit before opening fixture or removing optics. To maintain maximum light output, this fixture should be cleaned periodically. Maintenance procedures sometimes require fixtures to be hosed down for good housekeeping. The supply circuit must be turned OFF and the fixture lens must be allowed to cool to the ambient room temperature before cleaning. Only mild, non-abrasive cleaning agents should be used. The force of water applied by a hose must not exceed 65 gallons per minute coming from a 1" diameter hose applied at a distance of 10 feet.

CAUTION: Clean polycarbonate lenses with damp cloth only to reduce chances of static charge build up. These periodic cleaning procedures are important to prevent the accumulation of dust and dirt which will impair the light output of the fixture. The polycarbonate lens should be regularly inspected for scratches and chips and, if damaged, must be replaced.

HIGH VIBRATION AREAS: Periodic inspection of fastener tightness is required; recommended every six (6) months.