

Please see last page for supporting documentation for this product(certificates, CAD files & drawings, IES files, wiring diagrams, etc).

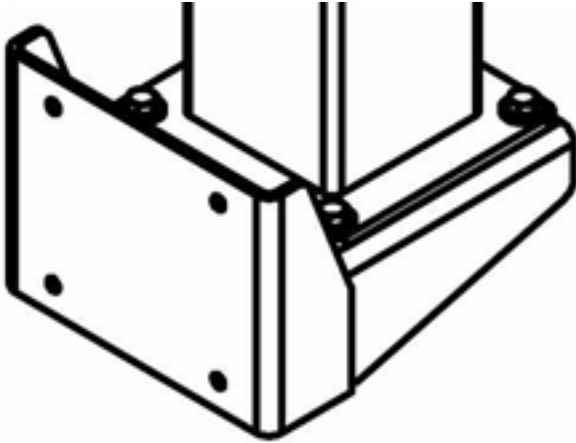

LM-XX-LMB-M2 Replacement Lower Mount Assembly for LM-25-7-5S-M1

Unit Type: Base Lower Wall Mounting Bracket for LM-25-7-5S-M1

Dimensions: 6" x 6.5" x 12.25"

Weight: -

Design: L-mount Wall Bracket

Materials: Carbon Steel

Finish: Powder Coated - Black

Mount: Side/Wall Mounting - (4) Mounting Holes

Quick Summary

Carbon Steel Construction

Powder Coated Finish

Special Orders- Requirements

Contact us for special requirements

Toll Free: 1-800-369-6671

Intl: 1214-616-6180

Fax: 1-903-498-3364

E-mail: sales@larsonelectronics.com

Made in the USA

The Larson Electronics LM-XX-LMB-M2 Mounting Bracket is designed for side or wall mounting LM-25-7-5S-M1 masts. This replacement lower mounting assembly has a powder coated black finish for durability in work sites. The L-mount bracket is suitable for installation on walls or vertical surfaces.

The LM-XX-LMB-M2 can be used to mount LM-25-7-5S-M1 masts on walls or vertical surfaces. Protected by a powder coated black finish, this accessory measures 6" x 6.5" (mounting surface) with 12.25" depth. The L-mount bracket is compatible with wall/side mounting installations via four holes and accepts LM-25-7-5S-M1 masts in a surface-mounted configuration.

Suggested Applications: Temporary lighting, construction sites, and security camera deployment. We can equip this mounting bracket with 1000W or 1500W Metal Halide lights or a wide variety of high powered LED lights with comparable power, including the [LED10WSA-160](#), [LEDLB-200X2E](#), [LEDLB-160X2E](#) or [LEDLB-80x2E](#).

At Larson Electronics, we do more than meet your lighting needs. We also provide replacement, retrofit, and upgrade parts as well as industrial grade power accessories. Our craftsmen can custom build any lighting system and/or accessories to fit the unique demands of your operation. A commitment to honesty, quality, and dependability has made Larson Electronics a leader in the lighting and electronics business since 1973. Contact us today at 800-369-6671 or message sales@larsonelectronics.com for more information about our custom options tailored to meet your specific industry needs.



Frequently Asked Questions (FAQ)



Links (Click on the below items to view):

- [ISO 9001 Certification](#)
- [Business Certificate](#)