

Wall Mount Bracket

LTB342-110T

Suitable for CMHT14/15/21XX Series



Properties

| | |
|--------------|--|
| Parameter | Wall mount bracket for CMHT14/15/21XX series |
| Construction | Aluminum Alloy and Steel |
| Dimension | 122×120×169mm(4.8"×4.7"×6.7") |
| Weight | 605g(1.3lbs) |

Dimensions:

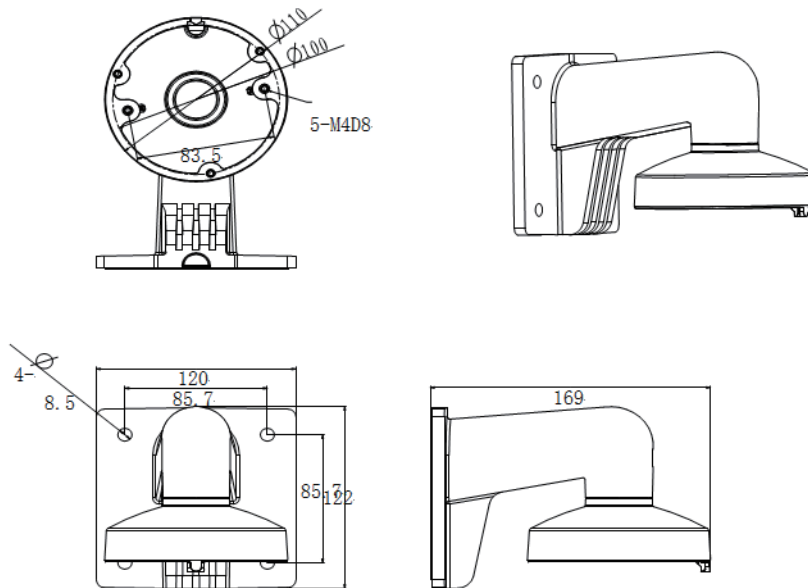

©2015 LT Security, Inc. All Rights Reserved. White papers, data sheets, quick start guides, and/or user manuals are for reference only and may or may not be entirely up to date or accurate based upon the version or models. Product names mentioned herein may be the unregistered and/or registered trademarks of their respective owners.