



# SERVICE PARTS LIST

BULLETIN NO.  
54-44-2550

## SERVICE PARTS

SPECIFY CATALOG NO. AND SERIAL NO. WHEN ORDERING PARTS		REVISED BULLETIN	DATE
<b>M12™ RIVET TOOL</b>			Dec. 2017
<b>CATALOG NO.</b>	<b>2550-20</b>	<b>SERIAL NUMBER</b>	<b>J53A</b>
WIRING INSTRUCTION			

**EXAMPLE:**  

00	0
----	---

 Component Parts (Small #) Are Included  
 When Ordering The Assembly (Large #).

SERVICE TABLE OF CONTENTS	
Page 1	Service Parts
Page 2	Lubrication Instructions

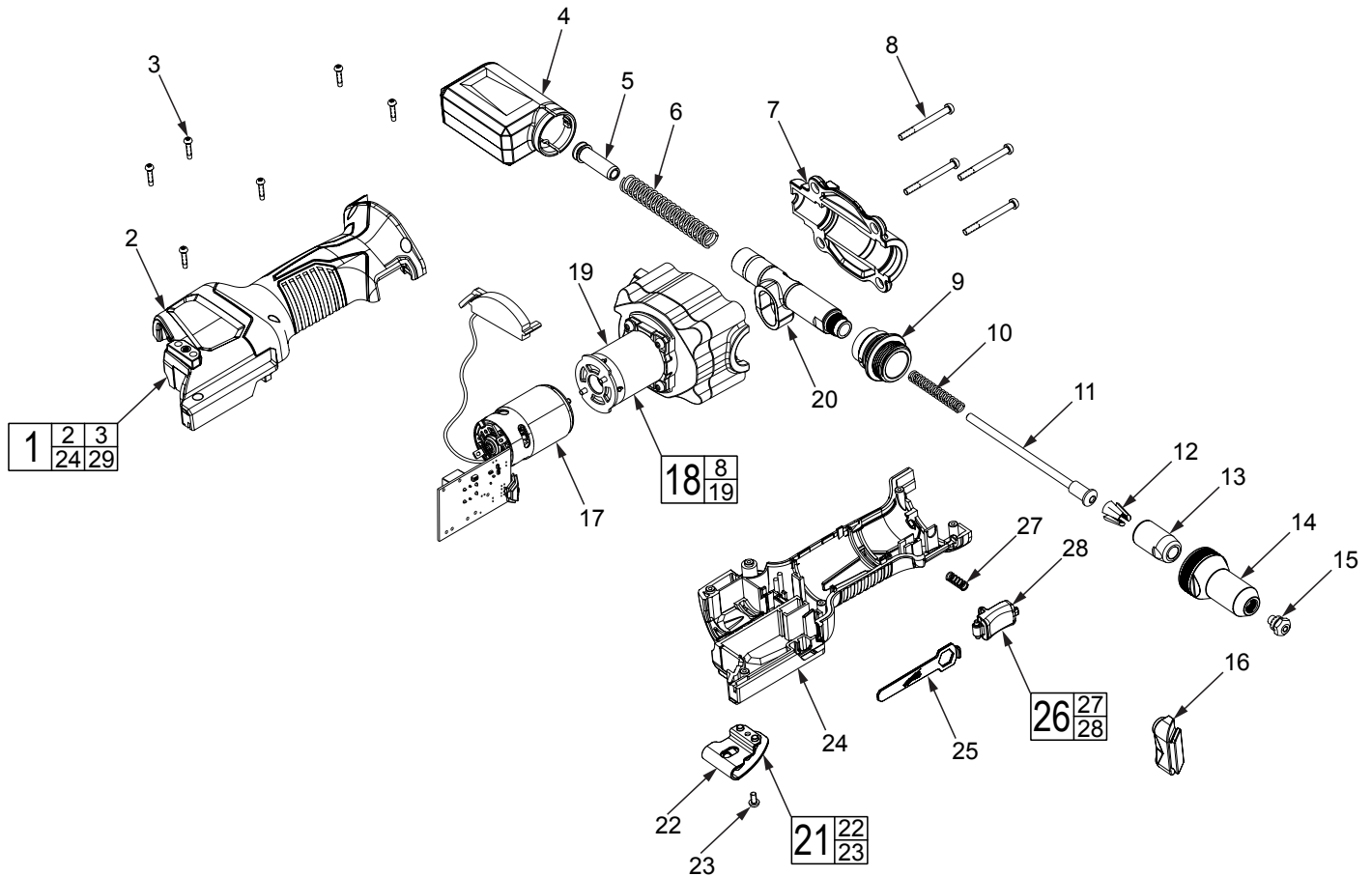
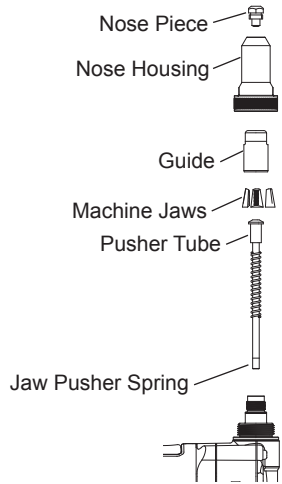

FIG.	PART NO.	DESCRIPTION OF PART	NO. REQ.	FIG.	PART NO.	DESCRIPTION OF PART	NO. REQ.
1	14-38-2550	Housing Kit	(1)	15e	48-54-0100	Retention Nose Piece Kit (Includes: 3/32", 1/8", 5/32" and 3/16" Retention Nose Pieces)	(1)
2	-----	Right Housing	(1)	16	43-72-2550	Nose Pieces Holder	(1)
3	-----	M3 Screw	(6)	17	14-30-2550	Motor & Electronics Assembly	(1)
4	43-72-2560	Mandrel Collector Assembly	(1)	18	14-30-2555	Gear Case Assembly	(1)
5	45-76-2550	Mandrel Exit Tube	(1)	19	-----	Gear Case	(1)
6	40-50-2550	Yoke Spring	(1)	20	45-98-0500	Yoke Assembly	(1)
7	31-15-2550	Top Housing	(1)	21	43-72-2555	Belt Clip Kit	(1)
8	05-81-2550	M4 x 0.7 Screw	(4)	22	-----	Belt Clip	(1)
9	45-22-2550	Sleeve	(1)	23	-----	Screw	(1)
10	40-50-2555	Jaw Pusher Spring	(1)	24	-----	Left Housing	(1)
11	44-60-2550	Pusher Tube Assembly	(1)	25	45-96-0500	Wrench	(1)
12	30-55-0035	Machine Jaws Kit (Set of 3)	(1)	26	45-72-0205	Trigger Kit	(1)
13	43-56-2550	Guide	(1)	27	-----	Trigger Spring	(1)
14	43-56-2555	Nose Housing	(1)	28	-----	Trigger	(1)
15a	48-98-0005	3/32" Non-Retention Nose Piece	(1)	29	12-20-2551	Service Nameplate (Not Shown)	(1)
15b	48-98-0010	1/8" Non-Retention Nose Piece	(1)	30	10-20-2551	Warning Label (Not Shown)	(1)
15c	48-98-0015	5/32" Non-Retention Nose Piece	(1)				
15d	48-98-0020	3/16" Non-Retention Nose Piece	(1)				

LUBRICATION INSTRUCTIONS



Clean and lubricate the nose of the tool after heavy use (5000 rivets) or if tool becomes contaminated with dust and debris.

1. Remove battery pack.
2. Remove the nose housing from the tool and the nose piece from the housing.
3. Remove the guide (with jaws), pusher tube, and spring from the tool.
4. Clean all pieces with a dry cloth and inspect for damage. If damaged, return to a MILWAUKEE service facility for repairs.
5. Apply a small amount of 51-08-4290 grease to the pieces and reassemble, as shown. Ensure the jaws are properly seated in the guide.

FIG.	PART NO.	DESCRIPTION OF PART	NO. REQ.
31	49-08-4290	T-Grease (14 oz.) (Not Shown)	(1)