

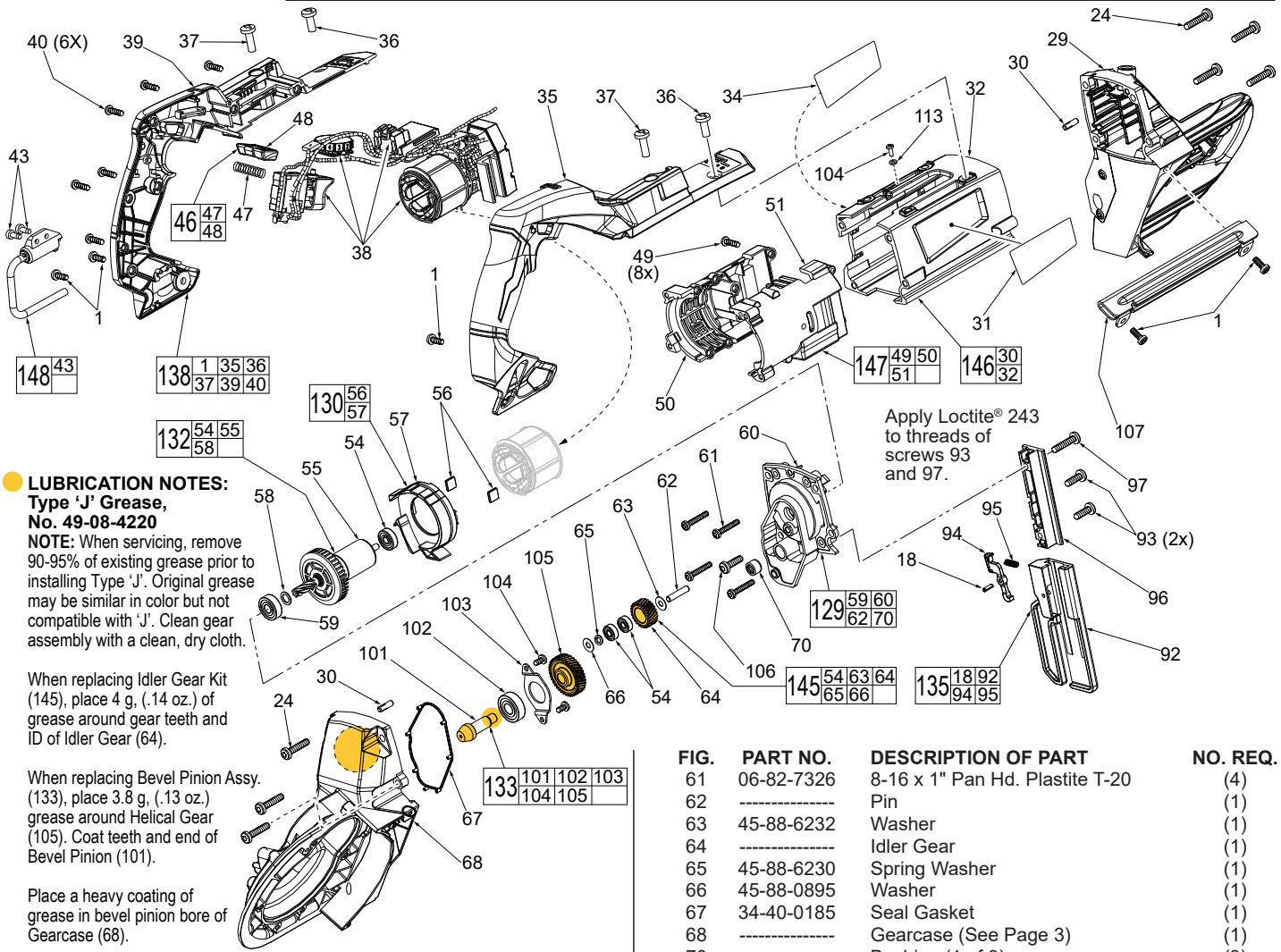

SERVICE PARTS LIST

BULLETIN NO.
54-40-2712

SPECIFY CATALOG NO. AND SERIAL NO. WHEN ORDERING PARTS		REVISED BULLETIN	DATE
M18 FUEL™ DEEP CUT BANDSAW		54-40-2711	Feb. 2022
CATALOG NO. 2729-20	STARTING SERIAL NO. F83C	WIRING INSTRUCTION See Page 4	



LUBRICATION NOTES:
Type 'J' Grease,
No. 49-08-4220

NOTE: When servicing, remove 90-95% of existing grease prior to installing Type 'J'. Original grease may be similar in color but not compatible with 'J'. Clean gear assembly with a clean, dry cloth.

When replacing Idler Gear Kit (145), place 4 g. (.14 oz.) of grease around gear teeth and ID of Idler Gear (64).

When replacing Bevel Pinion Assy. (133), place 3.8 g. (.13 oz.) grease around Helical Gear (105). Coat teeth and end of Bevel Pinion (101).

Place a heavy coating of grease in bevel pinion bore of Gearcase (68).

FIG.	PART NO.	DESCRIPTION OF PART	NO. REQ.
★ 1	06-82-5314	10-24 x 1/2" Pan Hd. Tapt. T-25 (5 of 17)	(17)
18	06-65-0115	Coiled Pin (1 of 3)	(3)
24	06-82-5376	12-24 x 1" Pan Hd. Taptite T-27 Screw	(7)
29	-----	Pulley Support (See Page 2)	(1)
30	-----	Pin	(2)
31	12-20-0062	Service Nameplate	(1)
32	-----	Outer Motor Housing	(1)
34	22-68-0010	Logo Plate	(1)
35	-----	Support Handle	(1)
36	06-82-5360	1/4-20 x .625" Pan Hd. Taptite T-30 Scr.	(2)
37	06-82-5382	1/4-20 x .75" Pan Hd. Taptite T-27 Screw	(2)
38	14-20-0117	Electronics Assembly	(1)
39	-----	Handle Cover	(1)
40	06-82-7270	8-16 x 5/8" Pan Hd. Plastite T-20 Screw	(6)
43	05-78-0910	M4 x 12mm Fillister Hd. Screw	(2)
46	45-24-9004	Shuttle Kit	(1)
47	40-50-0272	Shuttle Spring	(1)
48	42-42-0210	Lock-Off Shuttle	(1)
49	05-88-1200	M4 x 16 Pan Hd. Plastite T-20 Screw	(8)
50	-----	Motor Housing Cover	(1)
51	-----	Motor Housing Support	(1)
54	-----	Ball Bearing	(3)
55	-----	Rotor	(1)
56	42-28-0085	Rubber Block	(2)
57	-----	Baffle	(1)
58	45-88-0406	Washer (1 of 2)	(2)
59	02-04-0175	Ball Bearing (1 of 2)	(2)
60	-----	Diaphragm	(1)

FIG.	PART NO.	DESCRIPTION OF PART	NO. REQ.
61	06-82-7326	8-16 x 1" Pan Hd. Plastite T-20	(4)
62	-----	Pin	(1)
63	45-88-6232	Washer	(1)
64	-----	Idler Gear	(1)
65	45-88-6230	Spring Washer	(1)
66	45-88-0895	Washer	(1)
67	34-40-0185	Seal Gasket	(1)
68	-----	Gearcase (See Page 3)	(1)
70	-----	Bushing (1 of 3)	(3)
92	-----	Shoe Bumper	(1)
93	06-82-5330	10-32 x 5/8" Pan Hd. Taptite T-25	(2)
94	42-42-0060	Release Button	(1)
95	40-50-0845	Lever Release Spring	(1)
96	30-13-0015	T-Block	(1)
97	06-82-0065	10-32 x 1" Pan Hd. Taptite T-25	(1)
101	-----	Bevel Pinion	(1)
102	-----	Ball Bearing	(1)
103	-----	Bearing Plate	(1)
104	06-82-8828	8-32 x .313" Pan Hd. Taptite T-20	(3)
105	-----	Helical Gear	(1)
106	06-82-5358	12-24 x 3/4" Pan Hd. Taptite T-27	(1)
107	43-54-0085	Blade Guard	(1)
113	05-90-0225	Washer	(1)
129	14-13-0050	Diaphragm Kit	(1)
130	42-14-0320	Fan Baffle Kit	(1)
132	16-01-0205	Service Rotor Kit	(1)
133	32-60-0095	Bevel Pinion Assembly	(1)
135	42-18-0035	Shoe Bumper Kit	(1)
138	14-34-0105	Handle Assembly Kit	(1)
145	32-60-6230	Idler Gear Kit	(1)
146	14-38-0135	Outer Motor Housing Assembly	(1)
147	31-50-2729	Motor Cage Kit	(1)
148	14-36-0095	Hang Hook Assembly	(1)

SEE PAGE 3 FOR FASTENER TORQUE CHART

00 0

EXAMPLE:

Component Parts
(Small #) Are Included
When Ordering The
Assembly (Large #).

★ = Component change from
previous service parts list.

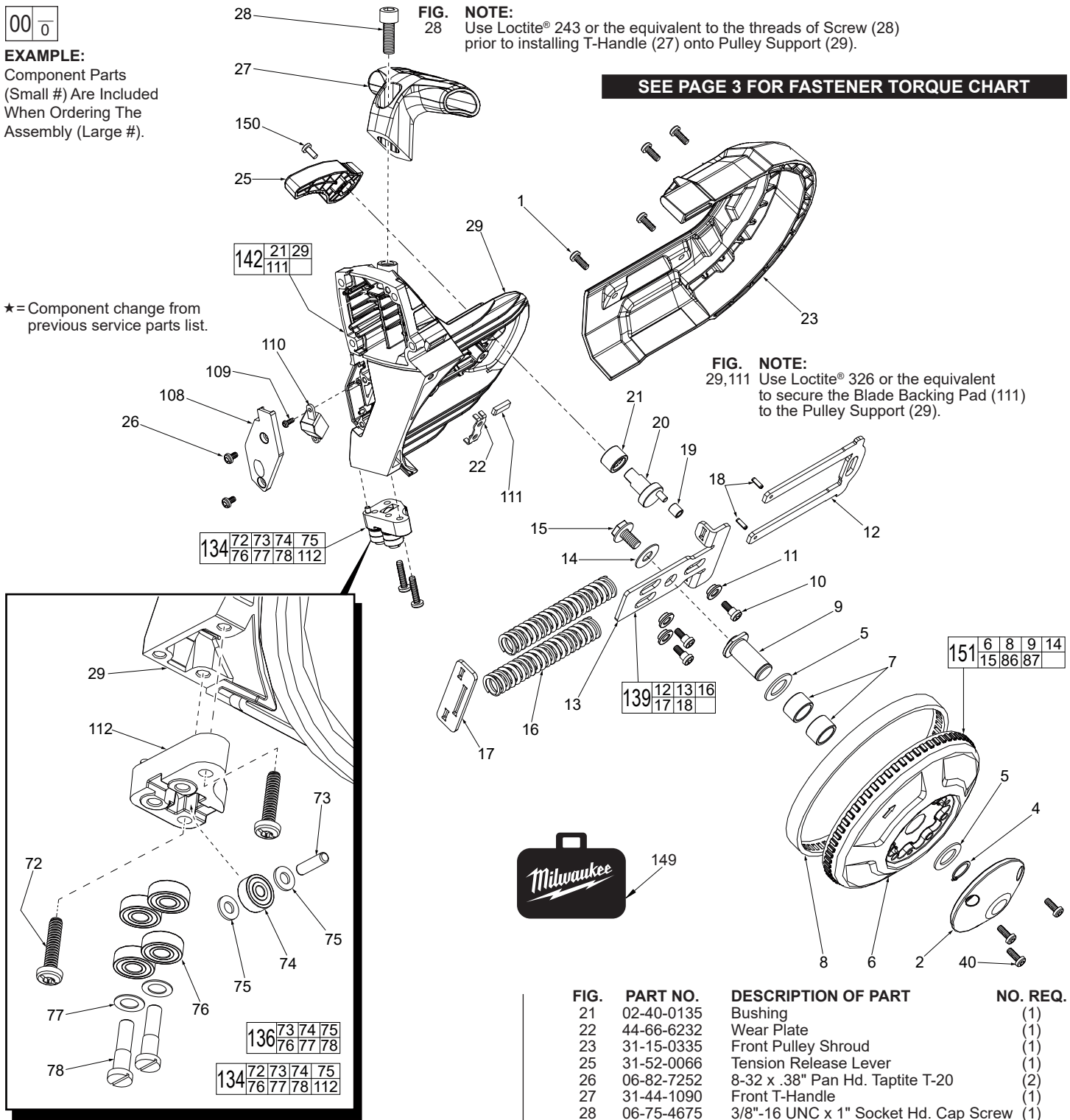

FIG. 28 NOTE:
Use Loctite® 243 or the equivalent to the threads of Screw (28) prior to installing T-Handle (27) onto Pulley Support (29).

SEE PAGE 3 FOR FASTENER TORQUE CHART

FIG. 29,111 NOTE:
Use Loctite® 326 or the equivalent to secure the Blade Backing Pad (111) to the Pulley Support (29).

FIG.	PART NO.	DESCRIPTION OF PART	NO. REQ.
★ 1	06-82-5314	10-24 x 1/2" Pan Hd. Tapt. T-25 (4 of 17)	(17)
2	31-15-0325	Pulley Cover (1 of 2)	(2)
4	34-60-1400	Snap Ring	(1)
5	45-88-7165	Washer	(2)
★ 6	28-95-2715	Front Pulley	(1)
★ 7	42-40-0585	Sleeve Bushing	(2)
8	45-69-0010	Pulley Tire (1 of 2)	(2)
★ 9	42-12-0015	Front Pulley Shaft	(1)
10	06-81-0075	Shoulder Screw	(3)
11	42-40-0115	Tension Bushing	(3)
12	-----	Driver Plate	(1)
13	-----	Support Plate	(1)
14	45-88-0395	Washer	(1)
15	06-75-0035	5/16-18 x 9/16" Screw	(1)
16	-----	Blade Tension Spring	(2)
17	-----	Contact Plate	(1)
18	06-65-0115	Coil Pin (2 of 3)	(3)
19	42-40-0105	Cam Bushing	(1)
20	45-08-0070	Cam Shaft	(1)

FIG.	PART NO.	DESCRIPTION OF PART	NO. REQ.
21	02-40-0135	Bushing	(1)
22	44-66-6232	Wear Plate	(1)
23	31-15-0335	Front Pulley Shroud	(1)
25	31-52-0066	Tension Release Lever	(1)
26	06-82-7252	8-32 x .38" Pan Hd. Taptite T-20	(2)
27	31-44-1090	Front T-Handle	(1)
28	06-75-4675	3/8"-16 UNC x 1" Socket Hd. Cap Screw	(1)
29	-----	Pulley Support	(1)
★ 40	06-82-7270	8-16 x 5/8" Pan Hd. Plastite T-20 Screw	(3)
72	06-82-5574	10-24 x 7/8" Pan Hd. Tapt. T-25 (2 of 4)	(4)
73	-----	Pin (1 of 2)	(2)
74	-----	Ball Bearing (1 of 2)	(2)
75	-----	Washer (2 of 4)	(4)
76	-----	Ball Bearing (4 of 8)	(8)
77	-----	Washer (2 of 4)	(4)
78	06-82-0120	12-24 UNC x .96" Slotted (2 of 4)	(4)
108	31-15-0345	LED Cover	(1)
109	05-81-0010	M3 x 8mm Screw	(1)
110	14-20-0115	LED Assembly	(1)
111	44-52-0120	Blade Backing Pad	(1)
112	-----	Front Roller Block	(1)
134	42-24-0015	Front Guide Roller Kit	(1)
136	14-46-0465	Guide Roller Kit	(1)
139	42-18-0015	Tensioning Mechanism Assembly	(1)
142	14-30-0058	Pulley Support Kit	(1)
149	42-55-0090	Carrying Case	(1)
150	06-82-7252	8-32 x .38 Pan Hd. M Screw T-20	(1)
★ 151	14-30-2729	Pulley Service Kit	(1)

LUBRICATION NOTES:
Type 'J' Grease, No. 49-08-4220

When installing Gearcase Cover Kit (126), place 4.8 g (.16 oz) grease to the Bevel Gear (79). Place 6 g (.21 oz.) to the large Spur Gear (80). Coat all of the gear teeth on small Spur Gear (81) with grease.

Coat Washers (58 & 86) and middle and ends of shafts (82 & 85) with J Grease.

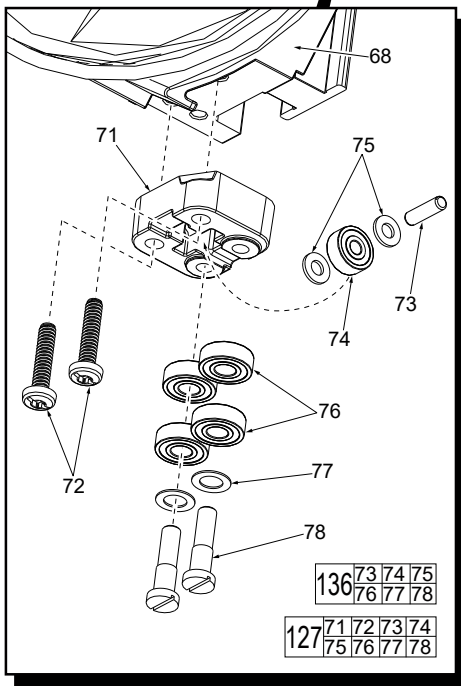
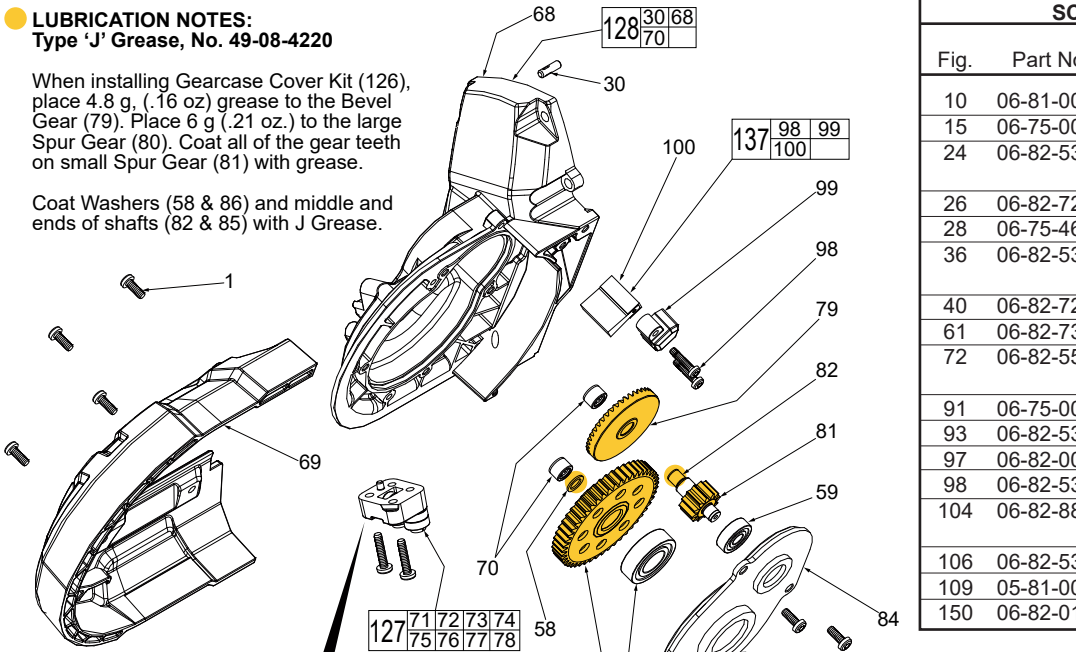

To properly tighten hex head screw (3), use a wooden dowel or a nylon rod in the opening between the rear pulley (7) and gearcase (26). Be careful not to damage pulley tire (8). Apply enough pressure to prevent rear pulley from turning. Torque hex head screw (3) to 312 in/lbs.

Service Tool 61-30-6232 can be ordered to secure rear pulley to tighten hex hd. screw.

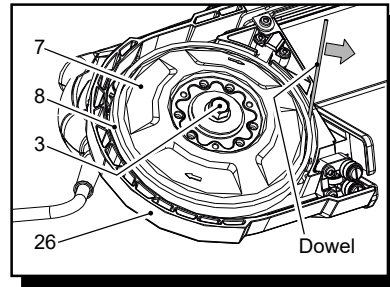

SCREW TORQUE CHART			
Fig.	Part No.	Location	Torque (In/Lbs.)
10	06-81-0075	Support Plate	36
15	06-75-0035	Support Plate	104
24	06-82-5376	Gearcase Pulley Support	38
26	06-82-7252	LED Cover	22
28	06-75-4675	Front T-Handle	83
36	06-82-5360	Handle Cover Support Handle	39
40	06-82-7270	Handle Cover	17
61	06-82-7326	Diaphragm	16
72	06-82-5574	Front Roller Block Rear Roller Block	39
91	06-75-0010	Rear Pulley	312
93	06-82-5330	T-Block	19
97	06-82-0065	T-Block	19
98	06-82-5346	Tire Cleaning Brush Cover	22
104	06-82-8828	Bearing Plate Ground Terminal	17
106	06-82-5358	Diaphragm	38
109	05-81-0010	LED Assembly	6
150	06-82-0145	Release Lever	22

* = Component change from previous service parts list.

LUBRICATION NOTES:
Type 'Y' Grease, No. 49-08-5270
Lightly coat both sides of Washers (89) and Clutch Plates (88) with Y Grease.

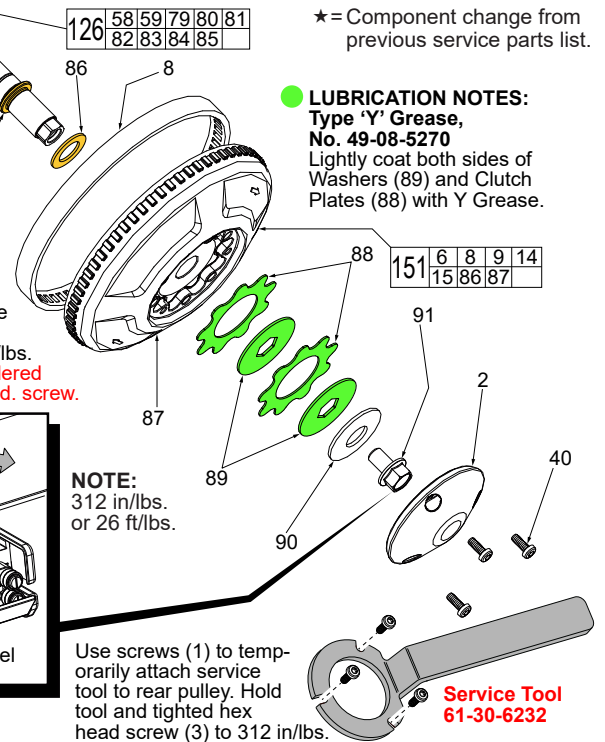

NOTE:
312 in/lbs.
or 26 ft/lbs.

Use screws (1) to temporarily attach service tool to rear pulley. Hold tool and tightened hex head screw (3) to 312 in/lbs.

Service Tool 61-30-6232

FIG.	PART NO.	DESCRIPTION OF PART	NO. REQ.
★ 1	06-82-5314	10-24 x 1/2" Pan Hd. Tapt. T25 (8 of 17)	(17)
2	31-15-0325	Pulley Cover (1 of 2)	(2)
8	45-69-0010	Pulley Tire (1 of 2)	(2)
30	-----	Pin (1 of 2)	(2)
★ 40	06-82-7270	8-16 x 5/8" Pan Hd. Plastite T-20 Screw	(3)
58	45-88-0406	Washer (1 of 2)	(2)
59	02-04-0175	Ball Bearing (1 of 2)	(2)
68	-----	Gearcase	(1)
69	31-15-0330	Rear Pulley Shroud	(1)
70	-----	Bushing (2 of 3)	(3)
71	-----	Rear Roller Block	(1)
72	06-82-5574	10-24 x 7/8" Pan Hd. Tapt. T-25 (2 of 4)	(4)
73	-----	Pin (1 of 2)	(2)
74	-----	Ball Bearing (1 of 2)	(2)
75	-----	Washer (2 of 4)	(4)
76	-----	Ball Bearing (4 of 8)	(8)
77	-----	Washer (2 of 4)	(4)
78	06-82-0120	12-24 UNC x .96" Slotted (2 of 4)	(4)
79	-----	Bevel Gear	(1)
80	-----	Spur Gear	(1)
81	-----	Spur Gear	(1)

FIG.	PART NO.	DESCRIPTION OF PART	NO. REQ.
82	-----	Shaft	(1)
83	-----	Ball Bearing	(1)
84	-----	Gearcase Cover	(1)
85	-----	Spindle	(1)
86	45-88-1580	Washer	(1)
★ 87	28-95-2710	Rear Pulley	(1)
88	43-06-0015	Clutch Plate	(2)
89	43-06-0010	Clutch Washer	(2)
90	40-50-0805	Disc Spring	(1)
91	06-75-0010	M Screw, 3/8"-16 UNC 5/8" Hex Hd.	(1)
98	06-82-5346	8-32 x 3/4" Pan Hd. Taptite T-20	(2)
99	-----	Tire Cleaning Brush Cover	(1)
100	-----	Tire Cleaning Brush	(1)
126	14-29-0057	Gearcase Cover Kit	(1)
127	42-28-0025	Rear Guide Roller Kit	(1)
128	14-30-0038	Gearcase Top Assembly	(1)
136	14-46-0465	Guide Roller Kit	(1)
137	44-60-0295	Tire Clearing Brush Kit	(1)
★ 151	14-30-2729	Pulley Service Kit	(1)

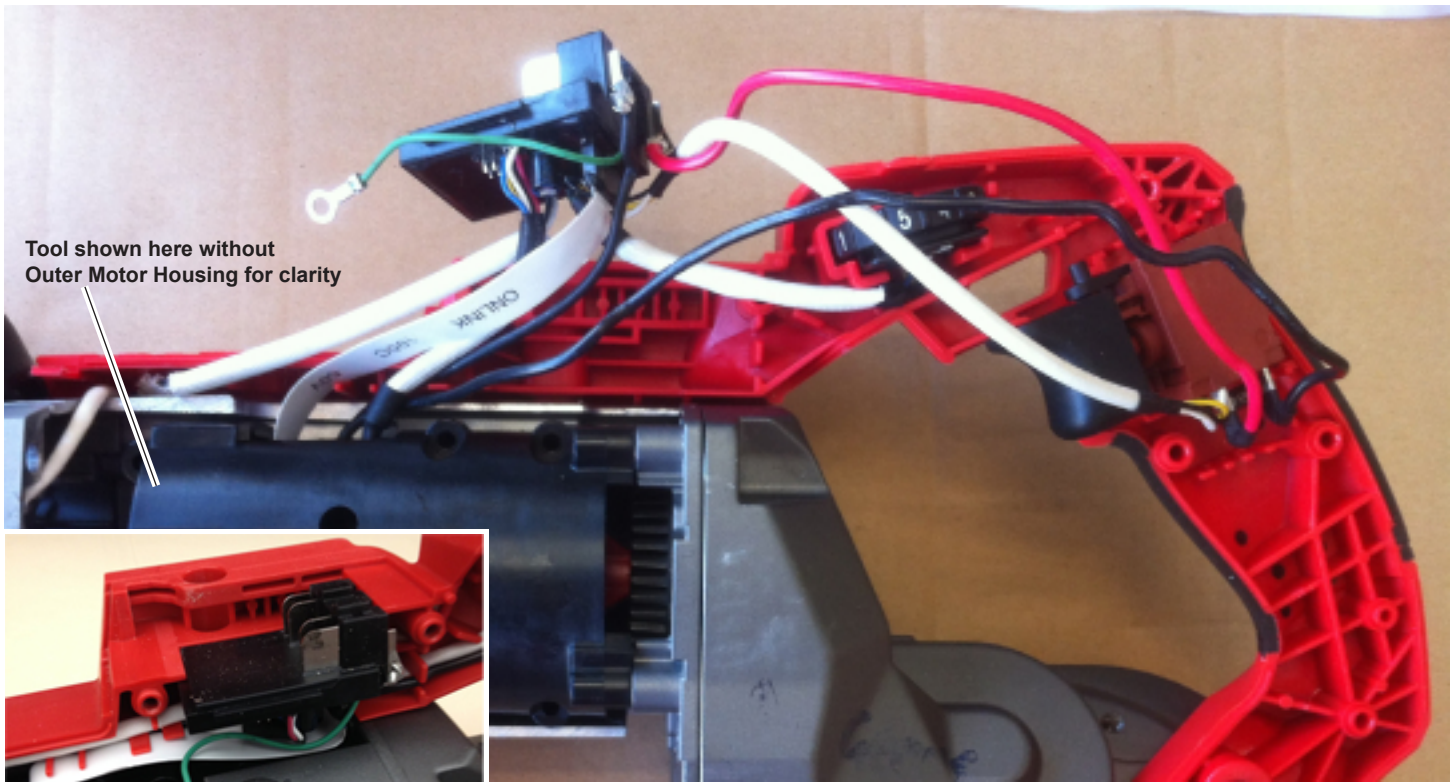

Tool shown here without Outer Motor Housing for clarity

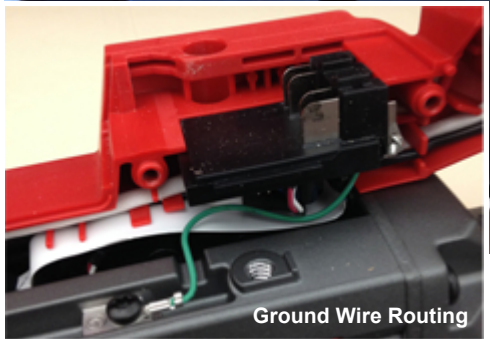

Ground Wire Routing

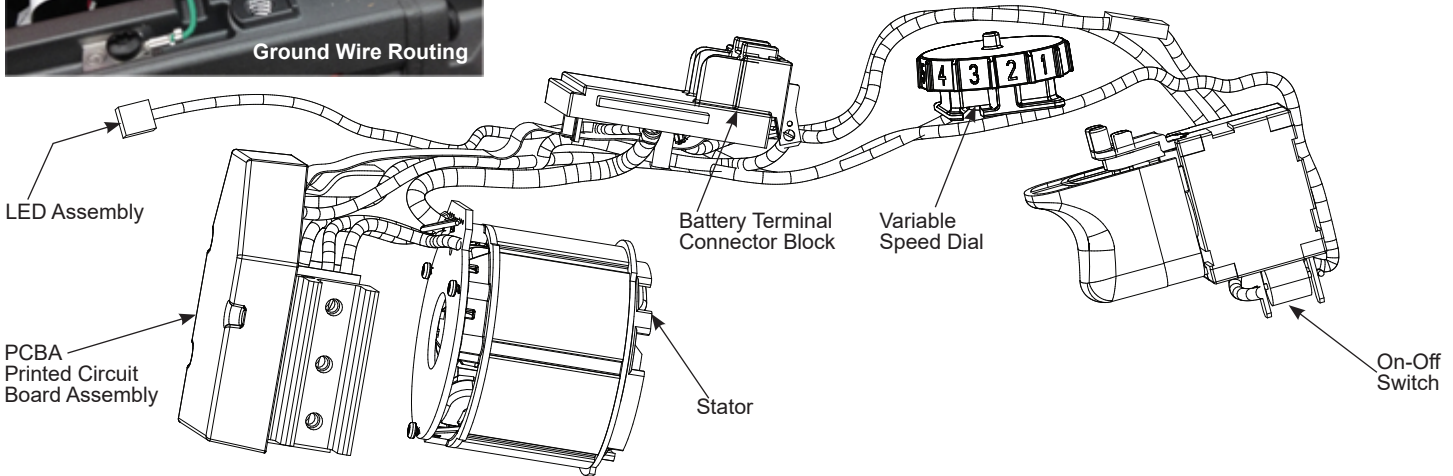

AS AN AID TO REASSEMBLY, TAKE NOTICE OF WIRE ROUTING AND POSITION IN WIRE GUIDES AND TRAPS WHILE DISMANTLING TOOL.

BE CAREFUL AND AVOID PINCHING WIRES BETWEEN HANDLE HALVES WHEN ASSEMBLING.

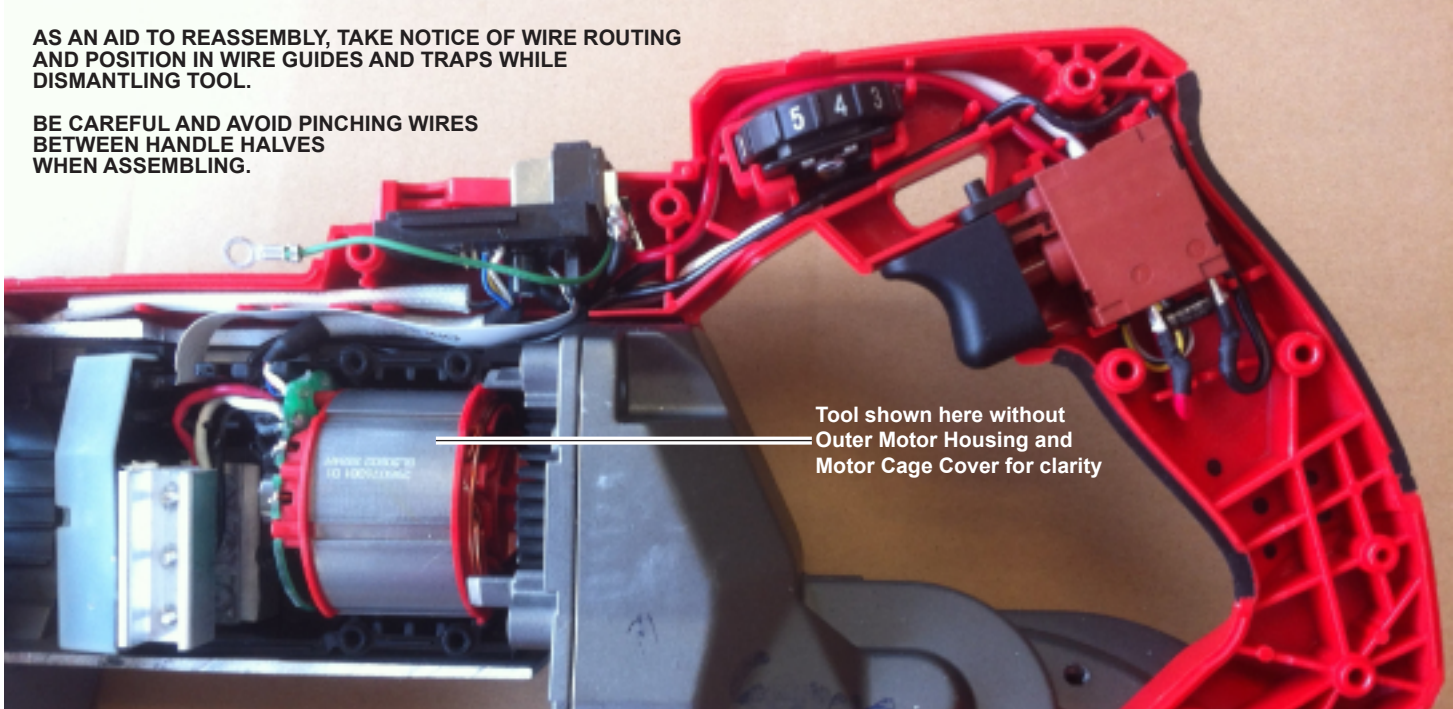

Tool shown here without Outer Motor Housing and Motor Cage Cover for clarity