

HYDRA HD™ Vandalproof Dome HC-0V31

Specification



KEY FEATURES:

- 45pps @ 1080p over RG59 cable & Cat5e
- HD video over coax cable up to 1500ft
- 3 ~ 10mm, vari-focal lens
- Day/Night functionality with ICR
- 30 IR LEDs (Up to 100ft)
- Back Light Compensation: BLC
- Digital WDR
- Built-in PoE / 12VDC

CONSTRUCTION:

- 4" Polycarbonate Bubble
- 3-Axis Gimbal
- Surface Mount Housing
- Aluminum Mounting Accessories (Optional)
- Weatherproof - IP66

AVAILABLE MODELS:

- EA-WM100

DIMENSIONS (INCH:MM):

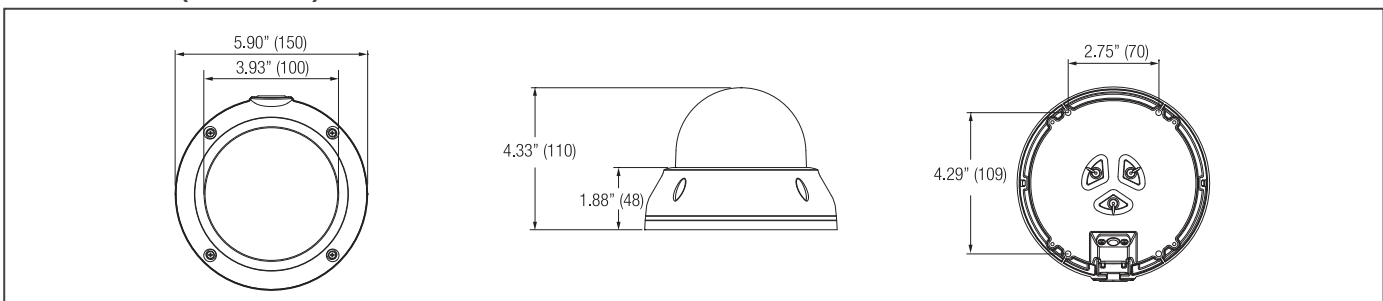

TECHNICAL SPECIFICATION:

HYDRA HD™ VF Lens Vandalproof Dome	HC-0V31
Resolution	1080P over Coax & Cat5e
Image Sensor	1/3" CMOS
Day/Night Functionality	Yes w/ ICR
Lens Type	3 ~ 10 mm VF Lens
Angle of View	110° (W) ~ 31.7° (T)
IR LEDs	30
IR LEDs Distance	Up to 100ft.
LEDs Illumination Angle	70° (W) ~ 27° (T)
Video Compression	H.264 / MJPEG
Frame Rate	45pps @1080P
Electronic Shutter	1/30 ~ 1/20,000 sec.
Minimum Illumination	0.8 Lux (Color), 0.0 Lux (B/W)
Power Over Ethernet (PoE)	IEEE 802.3af compliant
General Information	HC-0V31
Operating Temperature	-20°F ~ 122°F
Operating Humidity	Within 90% RH
Power Consumption	Up to 14W / 1A
Input Voltage	POE & 12VDC

*Specifications are subject to change without any prior notice.

UPGRADE ANALOG TO HD USING EXISTING COAX CABLE:

HYDRA HD™ delivers 1080p HD video to end users with existing coax up to 1500ft without any updates or changes to their existing infrastructure; if their cabling was enough to transmit a standard definition picture, then HYDRA HD™ is supported!



NEW CONVERTABLE GIMBAL DESIGN:



VF lens with no LED shown