



Key Features

- 10pps @5MP, 15pps @3MP, 30pps @2MP or 1.3MP
- 2.8 ~ 11mm, vari-focal Lens
- Day/Night functionality with ICR
- 30 IR LEDs (Up to 100ft.)
- Back Light Compensation: BLC
- Digital WDR
- Built-in PoE / 12VDC
- ONVIF version 2.2
- Built-in web server for resolution, bit-rate adjustment

Construction

- 4" Polycarbonate Bubble
- 3-Axis Gimbal
- Surface housing
- Aluminum Mounting Accessories (Optional)
- Weatherproof - IP 66

Available Accessories

- EA-WM100

New Convertible Gimbal Design



Dimensions (inch:mm)

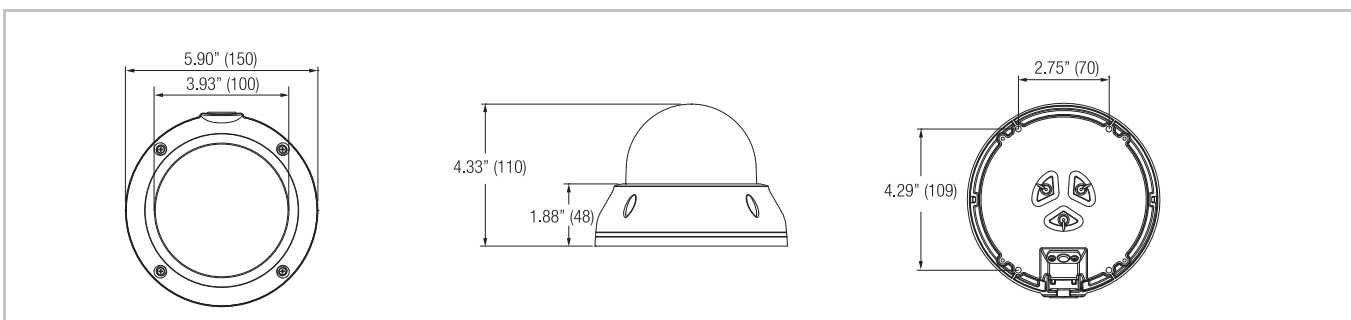

Technical Specification

5MP Flexible IP Vandalproof Dome	NC-5M-OV21
Resolution	5MP / 3MP / 2MP / 1.3MP
Image Sensor	1/3" CMOS
Day/Night Functionality	Yes w/ ICR
Lens Type	2.8 ~ 11 mm VF Lens
Angle of View	93° (W) ~ 31.7° (T)
IR LEDs	30
IR LEDs Distance	Up to 100ft.
LEDs Illumination Angle	80°
Video Compression	H.264 / MJPEG
Frame Rate	10pps@5MP, 15pps@3MP, 30pps@2MP
Electronic Shutter	1/30 ~ 1/20,000 sec.
Minimum Illumination	0.8 Lux (Color), 0.0 Lux (B/W)
Power Over Ethernet (PoE)	IEEE 802.3af compliant
General Information	NC-5M-OV21
Operating Temperature	0°F ~ 122°F
Operating Humidity	Within 90% RH
Power Consumption	Up to 14W / 1A
Input Voltage	POE & 12VDC

*Specifications are subject to change without any prior notice.

Smart IR LEDs get you covered.

Tired of "hotspots" or too much IR reflection? Our new LED dome cameras have got it covered - Smart IR LEDs.

All our new IP dome cameras come equipped with Smart IR LED technology that detects too much IR reflection and automatically compensates by decreasing the intensity.

