

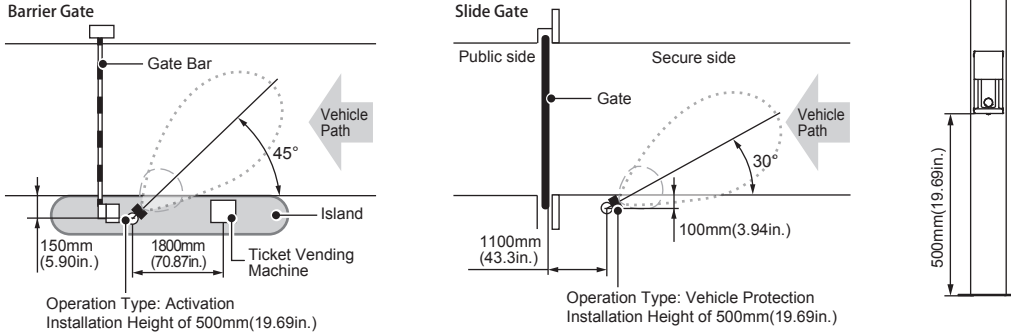

# OVS-01GT Quick Reference Guide

1. If used for Activation, go to section 2. If used for Vehicle protection, go to section 3.

2. If Activation mode, find the installation location by referring the following chart. Installation height has to be 500mm(19.69") from the ground.



3. If Vehicle protection mode, find the installation location by referring the following chart. Always recommended to install 700mm(27.56") far from barrier or slide gate. Installation height has to be 500mm(19.69") from the ground.

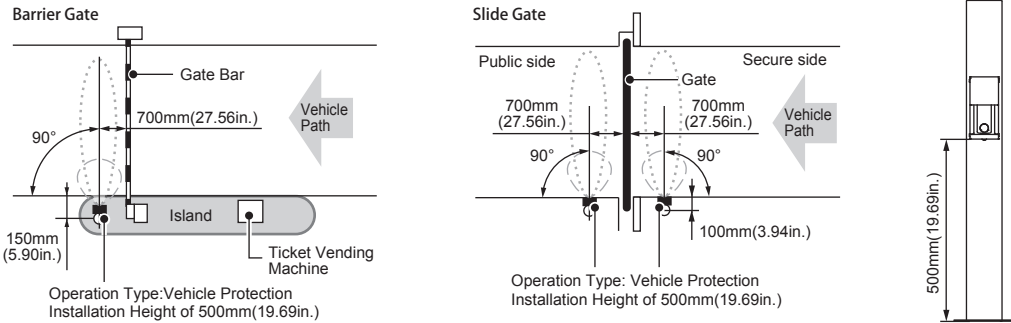

4. Install the sensor, wire it and apply power.

- [1] Make holes to mount the sensor.
- [2] Run a cable thru the post or pole.
- [3] Loosen the retaining screws on the bottom of the front cover and remove the front cover, detach the sensor unit.

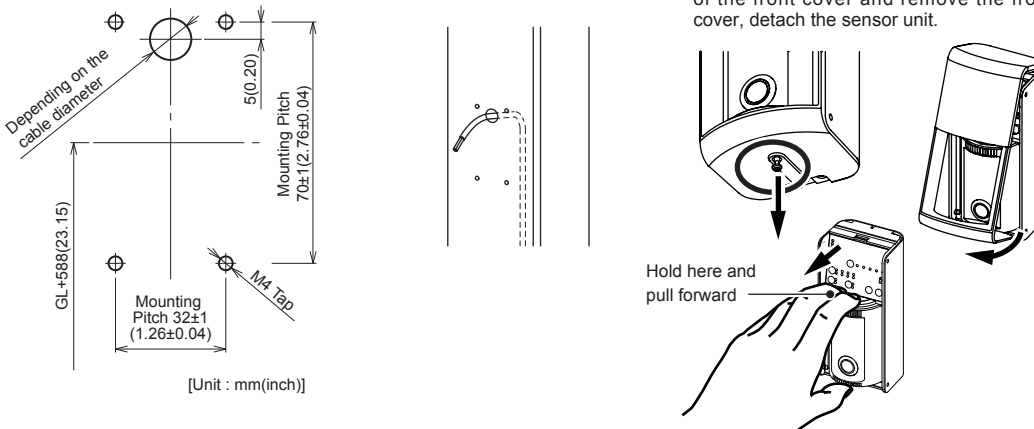

- [4] Mount the base using 4 screws.
- [5] Connect wires.

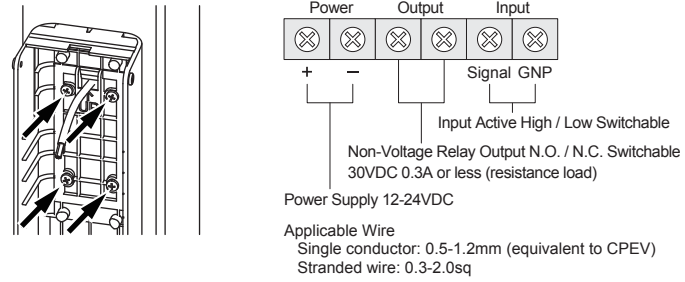

- [6] Attach the sensor body to the base and adjust the sensor angle.

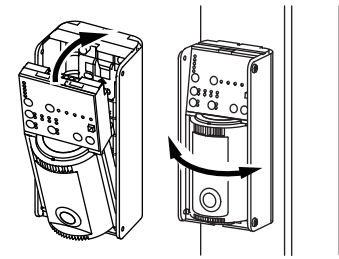

5. Set the Microwave maximum range and Sensor mode as follows:  
 Activation : 5m(16.4')  
 Vehicle protection : 3.5m(11.48') (factory default setting)  
 Usually, other settings can be default settings.  
 For detailed settings, refer to Advance Installation on page 17.

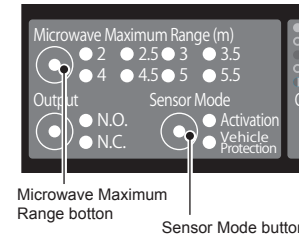

6. Perform sensor calibration in order to memorize the background of the detection area. Ensure no pedestrians or vehicles are present.

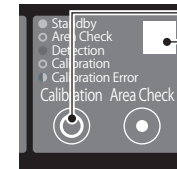

1. Press the Calibration button.
2. Operation indicator blinks in blue.
3. Step away from sensor and outside detection area.
4. Green LED lights when done correctly.

7. System operation check.  
 Check the entire coverage area by using actual vehicle.

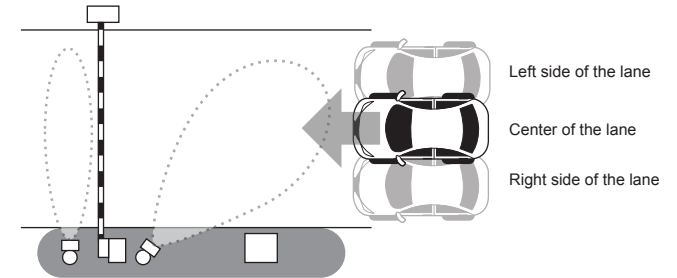

8. Put the front cover on the top of the base first, and attach it while spreading it open and pushing down the front cover.

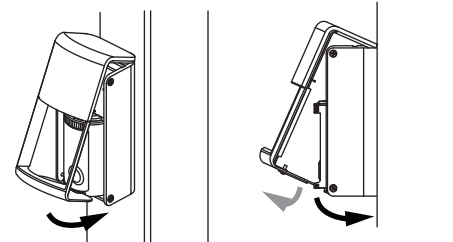

9. Tighten the front cover retaining screw.

