

LED



SUNLIGHT READABLE



19RTCSR

BUILT TO RUN 24 X 7 X 365 CONTINUOUSLY

OVERVIEW

ORION Images Sunlight readable LED monitors offer enhanced ultra-high brightness LED color display for high ambient light applications. The advantage of Transflective technology is that there is no extra heat generation lower power consumption, contrast and brightness is naturally brighter to help preserve the life of the back light. They are designed for use in applications such as industrial machinery, kiosk, ATM machines and and order confirmation system.

FEATURES

- » Metal Chassis
- » 1000 Nit (Indoor) / 1500 Nit (Outdoor) Brightness
- » Sunlight Readable Ultra Bright LED with Transflective Technology
- » 3D Comb Filter, Deinterlace, Transflective Enhancement, Multi-Language
- » BNC Video 2 In / 2 Out, HDMI 1 In, VGA 1 In, Audio 2 In, PC Stereo 1 In
- » Built-In Speakers
- » Wall and Rack Mount Kit



SPECIFICATIONS

19RTCSR	
Display	
Screen Size	19 Inch
Max. Resolution	1280 x 1024 @ 75Hz
Pixel Pitch	0.294 x 0.294mm
Brightness	1000cd/m ² (Indoor) / 1500cd/m ² (Outdoor)
Contrast Ratio	1000 : 1
Aspect Ratio	5 : 4
Viewing Angle (H/V)	170° / 160°
Display Color	16.7 Million
Response Time	< 5ms
Video System	NTSC / PAL
Interface	
Video In / Out (BNC Type)	2 In / 2 Out
Audio In (RCA Type)	2 In
HDMI In	1 In
VGA In (15Pin D-Sub)	1 In
PC Stereo In	1 In
Transmitter	
Remote Control	Yes
Audio	
Built-in Speakers	Yes (1W x 2)
Features	
Filter Type	3D Comb Filter
Deinterlacing	Yes
Noise Reduction Control (NR)	Yes
Multi Display Function	PIP / PBP
Trigger Source Switching	Yes (NO / NC)
Auto Source Sequencing	Yes
LCD Protection Glass	Yes
Transflective Enhancement	Yes
Multi Language	English, Spanish, French, German, Italian
General	
Outline Dimension	16.38" x 14.37" x 3.43"
Net Weight	6.25Kg (13.77 lbs)
Material / Color	Electronic galvanized iron / Black
Desk Top Stand	Tilt Back
Part / Labor	3year / 3year
Consumption: < On	< 45W
	AC100 ~ 240V(50/60Hz)
Electrical Ratings	
	DC12V
Operating Temperature	0 ~ 40° C / 32 ~ 104° F
Storage Temperature	-20 ~ 60° C / -4 ~ 140° F
Mounts	
VESA™ Mount Size	100 x 100mm
Wall	WB-5, WB-10, WB-30, WB-31
Ceiling	CMK-01
Rack	RMK-08

*Design and specifications are subject to change without notice

INPUT INTERFACE

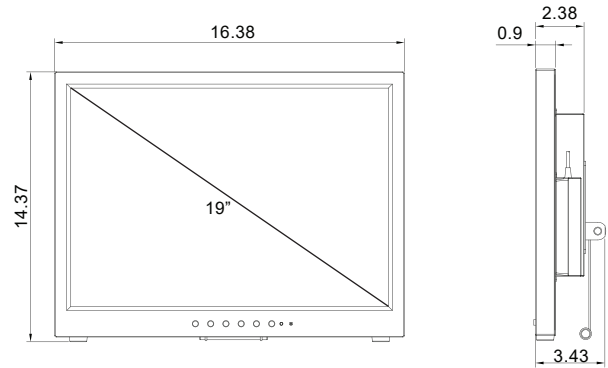
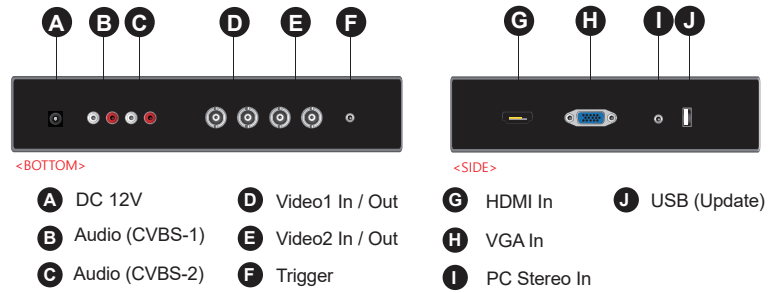

OPTIONAL MOUNTS

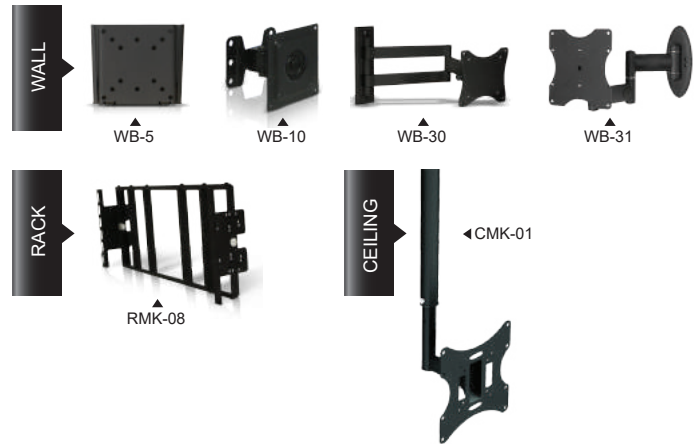

APPLICATION OF SUNLIGHT READABLE VIDEO WALLS



How does this technology work?

Transflective LCD modules hold both transmissive and reflective properties; the method of image display depends upon the conditions of the ambient environment. The display uses a backlight with a transmissive property in dark environments, and uses external light with a reflective property in bright environments.

Application

- Public Information Display (Bus, Railway, Airport)
- Digital Signage (Advertisement)
- ATM, Outdoor Kiosk (Bank, Shopping Mall, Theater)
- Gas Pump (Gas Station)

