

# Entry - Planning and installation

## Overview

The Entry system is designed to be as easy to install as possible by using a single network cable to link the Entry units.

The system consists of one or more entry panels, each associated with a control unit and as many internal video monitors as are required for the occupants.

A simple network can then be wired using Paxton or 3rd party PoE network switches to distribute power and data for the required layout.

The Entry configuration utility is used to remotely view and edit the settings stored within the Entry system devices. Individual devices or groups can be updated.

To ensure the best user experience and lifetime of your product we recommend your system is using the latest version of the Entry configuration utility by going here: <[www.paxton.info/1907](http://www.paxton.info/1907)>

When using Entry, the following minimum software versions are required:

- Paxton10 – v3.2 or higher
- Net2 – v4.27 or higher
- Entry – v2.20 or higher

## How many monitors and panels can I run ?

The Entry system can operate with up to 100 panels and 1000 monitors.

## Positioning the panel

In order to offer the best picture possible, it is advised where possible to avoid positioning the panel where the background will be significantly brighter than the subject. As with most cameras this can create a silhouetting effect due to the under exposure caused by the bright backlighting.

In situations where this cannot be avoided, additional lighting local to the panel will help to balance out the light and improve the exposure.

Where possible, it is recommended that the panel should be installed out of direct sunlight. Prolonged exposure to the sun can cause the panel to heat up well in excess of its specified operating temperature. Where this cannot be avoided, the use of a rain hood is recommended.

## One door / One monitor

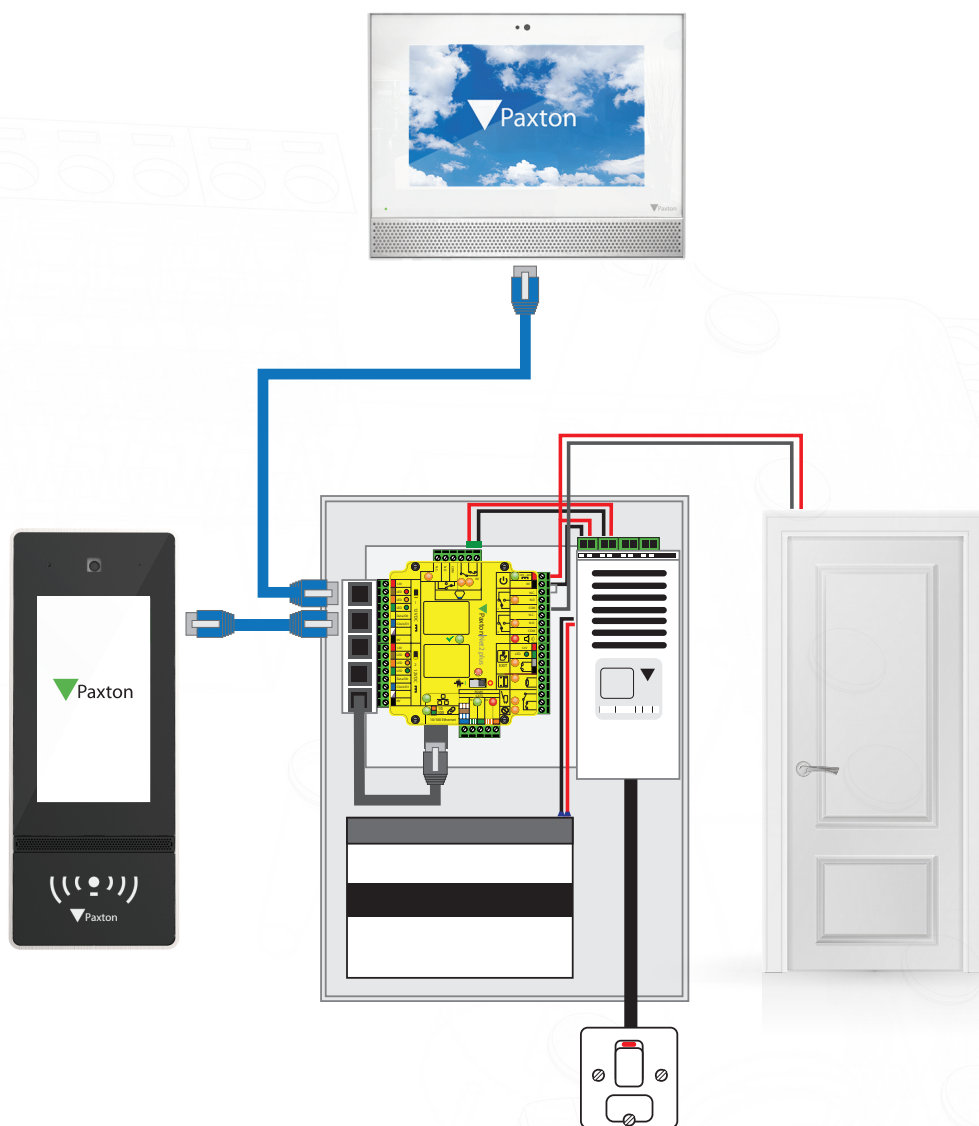

Entry can be installed as a standalone system using one control unit, one Entry panel and one monitor.

The Entry control unit provides PoE (Power over Ethernet) for the two units.

## Adding Entry to a Net2 system

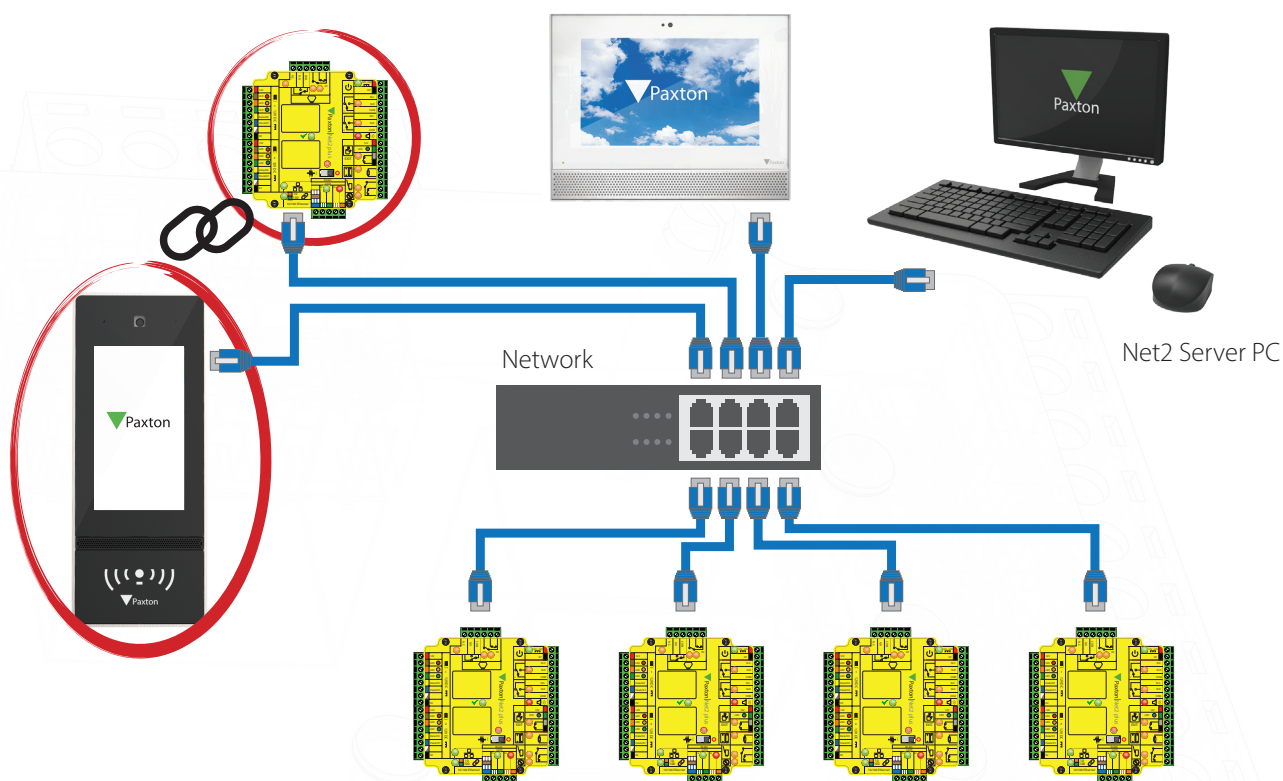

The Entry system can be fully integrated into a Net2 Access control system by simply adding panels and monitors to the existing Net2 network.

The Entry units require PoE power from a Entry control unit or a third party PoE switch. The Net2 system must be running v4.25 software or later.

Once a panel has been plugged into the network, it will ask for the serial number of the ACU that it is to be associated, which must be located on the same TCP/IP network (shown above in red). Multiple panels can run on the same network but require their own ACU for association.

All monitors plugged into the network will then communicate with the panel(s). They just require a local ID to be assigned so the correct one can be called from a panel.

This layout is by far the easiest to install but you will need to discuss the following points with the building IT manager. The network must:

1. Be compatible with IPv4 & IPv6 standards.
2. Support PoE network power.
3. Have the required bandwidth to handle the additional traffic.
4. Have the permission of the IT staff.

## Adding Entry to a Paxton10 system

The Entry system can be fully integrated into a Paxton10 system by simply adding panels and monitors to the existing Paxton10 network.

The Entry units require PoE power from a third party PoE switch. The Paxton10 system must be running v3.2 software or later.

The Entry panel must be on the same TCP/IP network as the Paxton10 system. Multiple panels can run on the same network and require their own door controller. The Entry panels will need to be bound to the Paxton10 system and setup in the Paxton10 software, for more information on this see AN0045 <[www.paxton.info/4932](http://www.paxton.info/4932)> .

All monitors plugged into the network will then communicate with the panel(s). They require a local ID to be assigned so the correct monitor can be called from a panel.

The layout below is by far the easiest to install, but you will need to discuss the following points with the building IT manager. The network must:

1. Be compatible with IPv4 & IPv6 standards
2. Support PoE network power
3. Have the required bandwidth to handle the additional traffic
4. Have the permissions of the IT staff

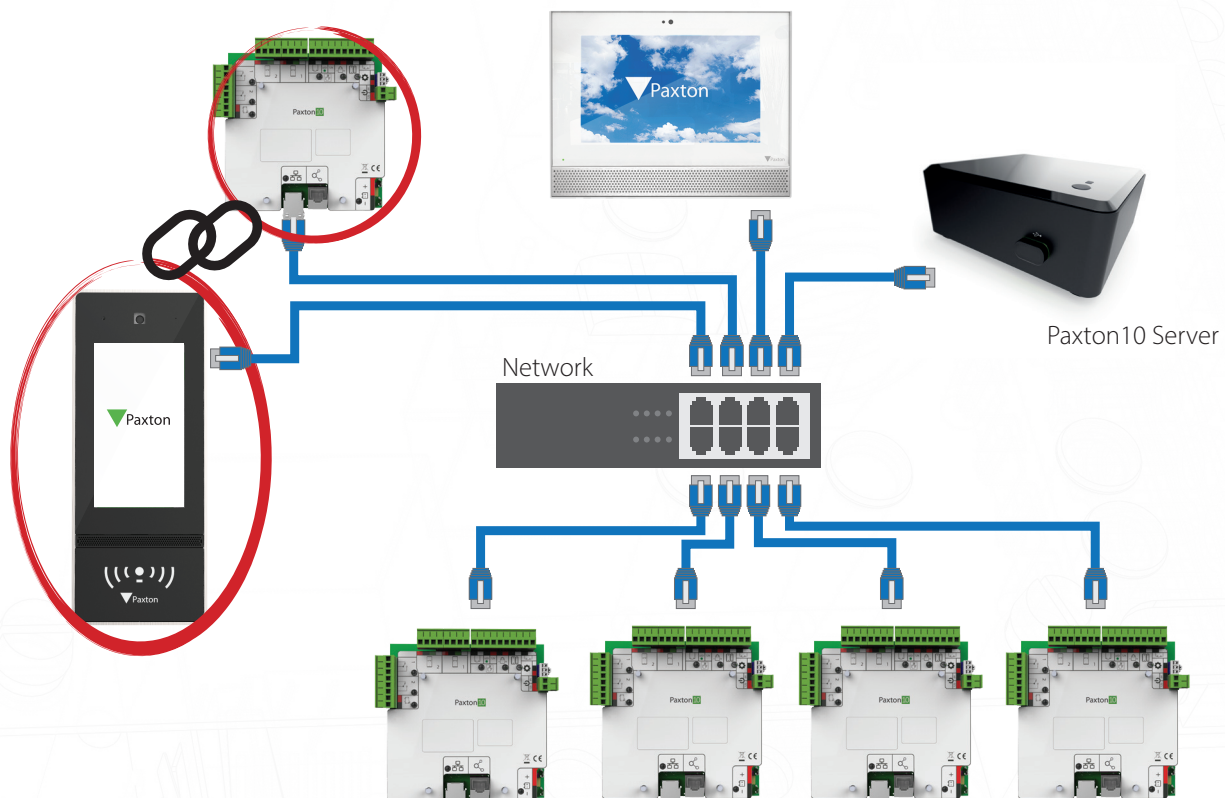

## One door / Multiple monitors

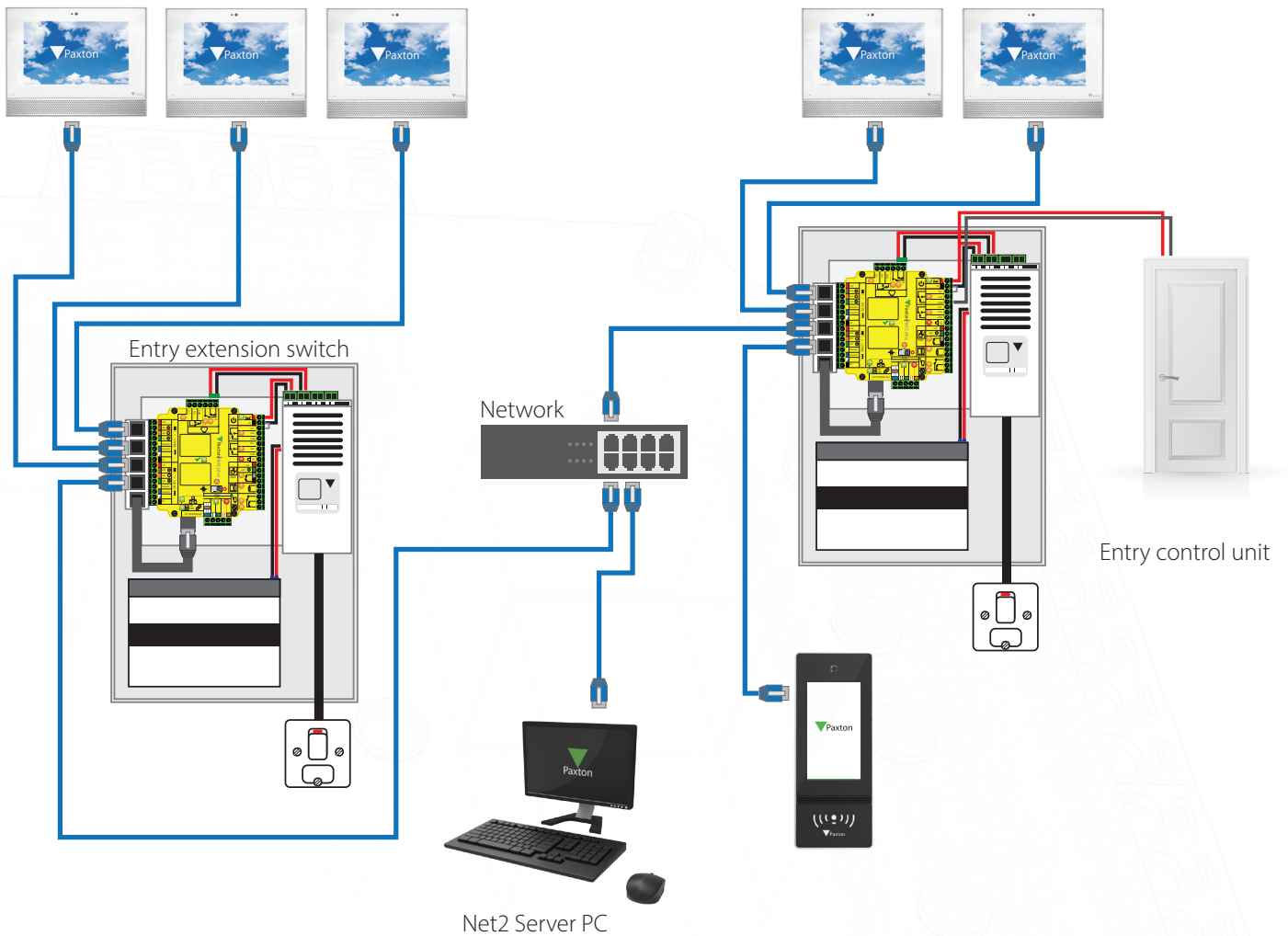

The Entry control unit has four PoE ports and one standard network port. The PoE ports can be used to power panels or monitors. All five network ports can be used for data to expand the network.

The system can be configured to call more than one monitor in a single location by giving them the same monitor ID.

The Entry extension switch has five ports that can be used to expand the network. 3rd party PoE and standard switches may also be used within the network for power and data.

## Multiple Doors / Multiple Monitors

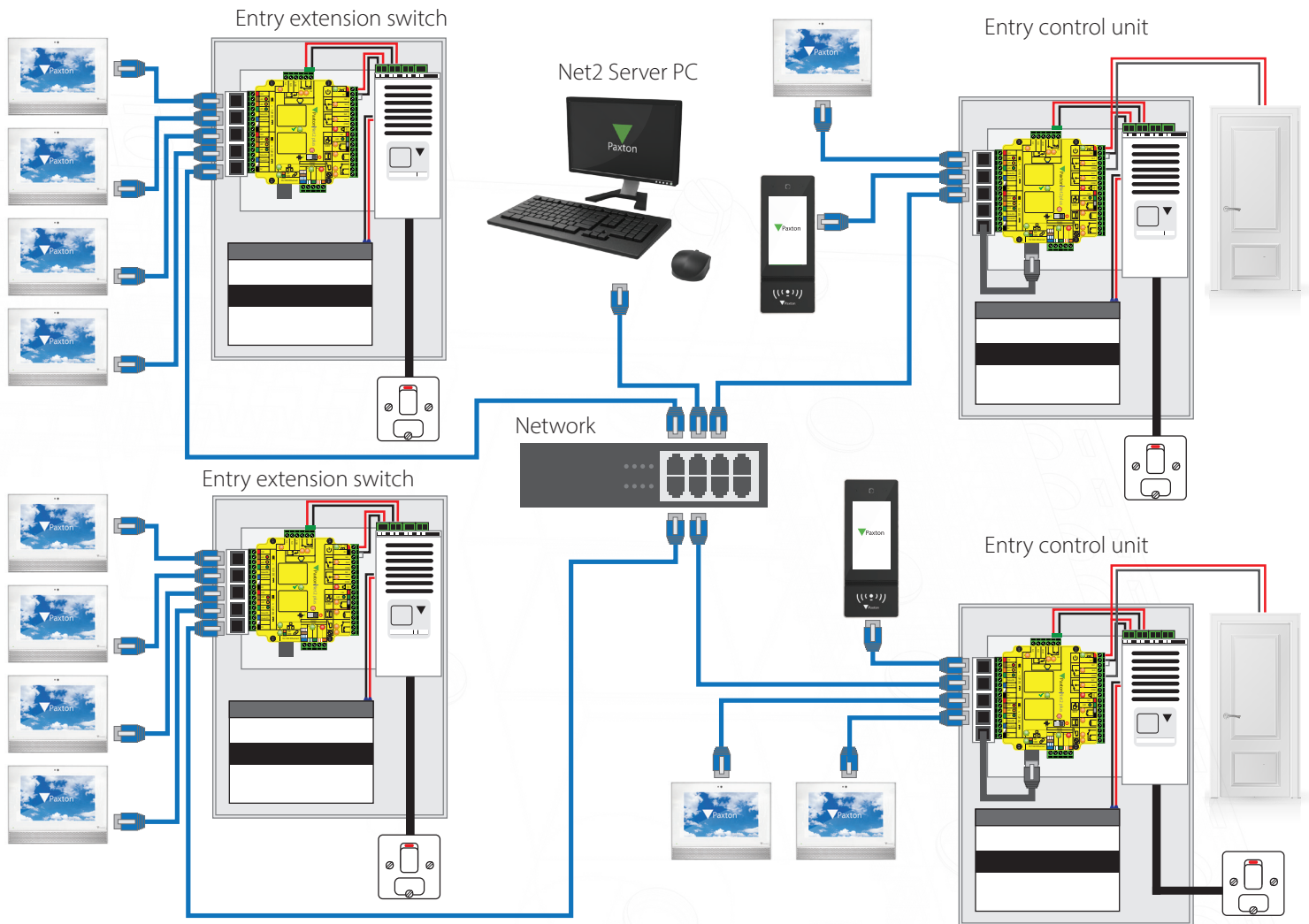

Very large systems can be configured using multiple panels and monitors.

Each panel must be associated with its own ACU located on the same network.

All the monitors on a single network can be called by any panel. You should therefore ensure that the ID or Name that you give a monitor clearly states its location to help the visitor call the correct monitor.