



Specifications subject to change without notice.

Ordering Information				
Nominal Pipe Size	Model	Part #	Replacement PCB #	
2"	DN50	VSR-AT-2	1116102	1029074
2 1/2"	DN65	VSR-AT-2 1/2	1116125	1029075
3"	DN80	VSR-AT-3	1116103	1029076
3 1/2"	-	VSR-AT-3 1/2	1116135	1029077
4"	DN100	VSR-AT-4	1116104	1029078
5"	-	VSR-AT-5	1116105	1029079
6"	DN150	VSR-AT-6	1116106	1029080
8"	DN200	VSR-AT-8	1116108	1029081

Optional Power Supply: Ordering Information		
Model	Description	Part Number
-	Power Supply	3006479
BT-80	12V Battery-8AH (2 REQUIRED)	5130084

Optional Test Switch: Ordering Information		
Model	Description	Part Number
ATC-1	Single Zone Test Control	1000221
ATC-4	Four Zone Test Control	1000224
SGB-R	Single Gang Box-Red	1000483
DGB-R	Double Gang Box-Red	1000484

General Information

The model VSR-AT is an electronic vane type waterflow switch for use on wet sprinkler systems. It is UL Listed and FM Approved for use on steel pipe schedules 10 thru 40 sizes 2" thru 8". See ordering Information chart.

The VSR-AT may also be used as a sectional waterflow detector on large systems. The VSR-AT has two sets of alarm contacts and an adjustable instantly recycling electronic retard. The alarm contacts are actuated when a flow of 10 GPM (38 LPM) or more occurs downstream of the device. The flow condition must exist for a period of time necessary to overcome the selected retard time.

The VSR-AT may be remotely tested without flowing water by using the optional auto test Control model ATC-1 or ATC-4 or the use of addressable relays and monitor modules as part of a listed addressable

UL, CUL, FM Approved

Service Pressure: 450 PSI (31 BAR) - UL

Flow Sensitivity Range for Signal:

4-10 GPM (15-38 LPM) - UL

Maximum Surge: 18 FPS (5.5 m/s)

Contact Ratings: 2.5 AMP @ 125/250 VAC & 30 VDC

Power Requirements: 24 VDC From Listed or Approved Source
With Battery Backup

Typical Current Draw:

Standby 20 mA

Alarm 65 mA

Autotest 120 mA

Conduit Entrances: Two knockouts provided for 1/2" conduit.

Environmental Specifications:

- NEMA 4/IP54 Rated Enclosure suitable for indoor or outdoor use with factory installed gasket and die-cast housing when used with appropriate conduit fitting.
- Temperature Range: 40°F - 120°F, (4.5°C - 49°C) - UL
- Non-corrosive sleeve factory installed in saddle.

Service Use:

Automatic Sprinkler

NFPA-13

One or two family dwelling

NFPA-13D

Residential occupancy up to four stories

NFPA-13R

National Fire Alarm Code

NFPA-72

Important: This document contains important information on the installation and operation of VSR-AT waterflow switches. Please read all instructions carefully before beginning installation. A copy of this document is required by NFPA 72 to be maintained on site.

⚠ WARNING

- Installation must be performed by qualified personnel and in accordance with all national and local codes and ordinances.
- Shock hazard. Disconnect power source before servicing. Serious injury or death could result.
- Risk of explosion. Not for use in hazardous locations. Serious injury or death could result.

CAUTION

Waterflow switches that are monitoring wet pipe sprinkler systems shall not be used as the sole initiating device to discharge AFFF, deluge, or chemical suppression systems. Waterflow switches used for this application may result in unintended discharges caused by surges, trapped air, or short retard times.

fire alarm panel.

When the auto test feature is initiated, the VSR-AT performs a self test to ensure compliance with UL requirements regarding waterflow detection and retard time. In addition, the auto test feature ensures the integrity of the paddle/trip stem assembly. A successful completion of the auto test will activate both sets of normally open contacts on the flow switch. If the auto test detects a problem with the trip stem/paddle assembly or if there is no water in the pipe, neither normally open contact will operate and the flow switch will indicate a trouble condition at the test switch and transmit a trouble signal to the fire alarm panel.

Enclosure

The VSR-AT switches and retard device are enclosed in a general purpose, die-cast housing. The cover is held in place with two tamper resistant screws which require a special key for removal.

Installation (see Fig. 1)

These devices may be mounted on horizontal or vertical pipe. On horizontal pipe they shall be installed on the top side of the pipe where they will be accessible. The device should not be installed within 6" (15 cm) of a fitting which changes the direction of the waterflow or within 24" (60 cm) of a valve or drain.

Drain the system and drill a hole in the pipe using a hole saw in a slow speed drill (see Fig. 1). Clean the inside pipe of all growth or other material for a distance equal to the pipe diameter on either side of the hole. Roll the vane so that it may be inserted into the hole; do not bend or crease it. Insert the vane so that the arrow on the saddle points in the direction of the waterflow. Take care not to damage the non-corrosive bushing in the saddle. The bushing should fit inside the hole in the pipe. Install the saddle strap and tighten nuts alternately to required torque (see the chart in Fig. 1). The vane must not rub the inside of the pipe or bind in any way.

⚠ CAUTION

Do not trim the paddle. Failure to follow these instructions may prevent the device from operating and will void the warranty. Do not obstruct or otherwise prevent the tripstem of the flowswitch from moving when water flows as this could damage the flowswitch and prevent an alarm. If an alarm is not desired, a qualified technician should disable the alarm system.

CAUTION

Do not leave cover off for an extended period of time as leaving the cover off could result in damage to the VSR and result in improper operation. On horizontal installations, it may be necessary to install a vent such as the Potter PAV or similar to exhaust air out of the system and allow the piping to fill with water to ensure proper operation of the Auto Test VSR.

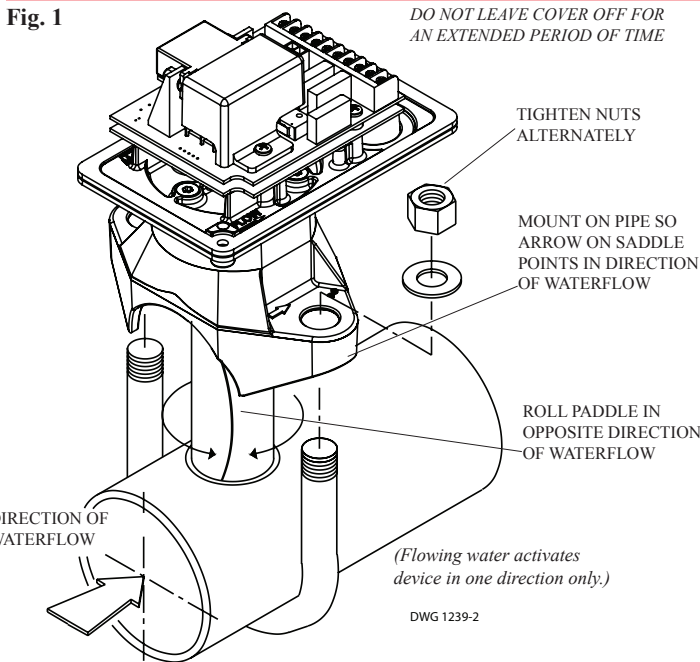

Retard Adjustment

The delay can be adjusted by turning switch S1 (see Fig. 6) to the desired time delay (0 = no delay and 9 = 90 second delay). Factory setting is set at 3 = 30 second delay. The time delay should be set at the minimum required to prevent false alarms.

CAUTION

Hole must be drilled perpendicular to the pipe and vertically centered. Refer to the Compatible Pipe/Installation Requirements chart for size.

Correct	Incorrect

DWG# 1146-1F

Compatible Pipe/ Installation Requirements																
Model	Nominal Pipe Size		Nominal Pipe O.D.		Pipe Wall Thickness								Hole Size		U-Bolt Nuts Torque	
					Schedule 10 (UL)		Schedule 40 (UL)		BS-1387 (LPC)		DN (VDS)					
	inch	mm	inch	mm	inch	mm	inch	mm	inch	mm	inch	mm	inch	mm	ft-lb	n-m
VSR AT-2	2	DN50	2.375	60.3	0.109	2.77	0.154	3.91	0.142	3.6	0.091	2.3	1.25 ± .125/-0.062	33.0 ± 2.0	20	27
VSR AT-2 1/2	2.5	-	2.875	73.0	0.120	3.05	0.203	5.16	-	-	-	-				
VSR AT-2 1/2	-	DN65	3.000	76.1	-	-	-	-	0.142	3.6	0.102	2.6				
VSR AT-3	3	DN80	3.500	88.9	0.120	3.05	0.216	5.49	0.157	4.0	0.114	2.9				
VSR AT-3 1/2	3.5	-	4.000	101.6	0.120	3.05	0.226	5.74	-	-	-	-				
VSR AT-4	4	DN100	4.500	114.3	0.120	3.05	0.237	6.02	0.177	4.5	0.126	3.2				
VSR AT-5	5	-	5.563	141.3	0.134	3.40	0.258	6.55	-	-	-	-				
VSR AT-5	-	DN125	5.500	139.7	-	-	-	-	0.197	5.0	0.142	3.6				
VSR AT-6	6	DN150	6.625	168.3	0.134	3.40	0.280	7.11	0.197	5.0	0.157	4.0				
VSR AT-8	8	DN200	8.625	219.1	0.148	3.76	0.322	8.18	0.248	6.3	0.177	4.5				

Fig. 2
To remove knockouts: Place screwdriver at inside edge of knockouts, not in the center.

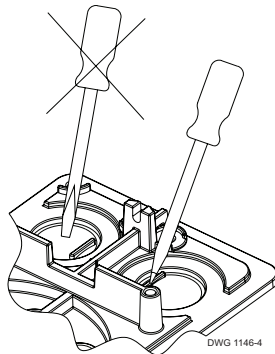

NOTICE

Do not drill into the base as this creates metal shavings which can create electrical hazards and damage the device. Drilling voids the warranty.

Fig. 3 Switch Terminal Connections Clamping Plate Terminal

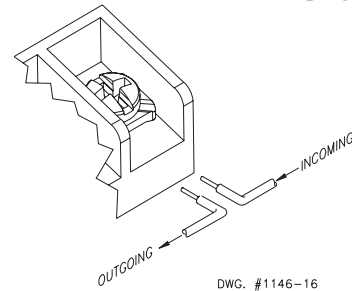

WARNING

An uninsulated section of a single conductor should not be looped around the terminal and serve as two separate connections. The wire must be severed, thereby providing supervision in the event that the wire become dislodged from under the terminal. Failure to sever the wire may render the device inoperable risking severe property damage and loss of life.

Do not strip wire beyond 3/8" of length or expose an uninsulated conductor beyond the edge of the terminal block. When using stranded wire, capture all strands under the clamping plate.

Testing

The frequency of inspection and testing for the Model VSR-AT and its associated protective monitoring system shall be in accordance with applicable NFPA Codes and Standards and/or the authority having jurisdiction (manufacturer recommends quarterly or more frequently).

An inspector's test valve shall be provided for commissioning and test purposes when required by the AHJ. If there are no provisions for testing the operation of the flow detection device on the system, application of the VSR-AT is not recommended or advisable.

A minimum flow of 10 GPM (38 LPM) is required to activate this device.

NOTICE

Advise the person responsible for testing of the fire protection system that this system must be tested in accordance with the testing instructions.

Fig. 4 Mounting Dimensions

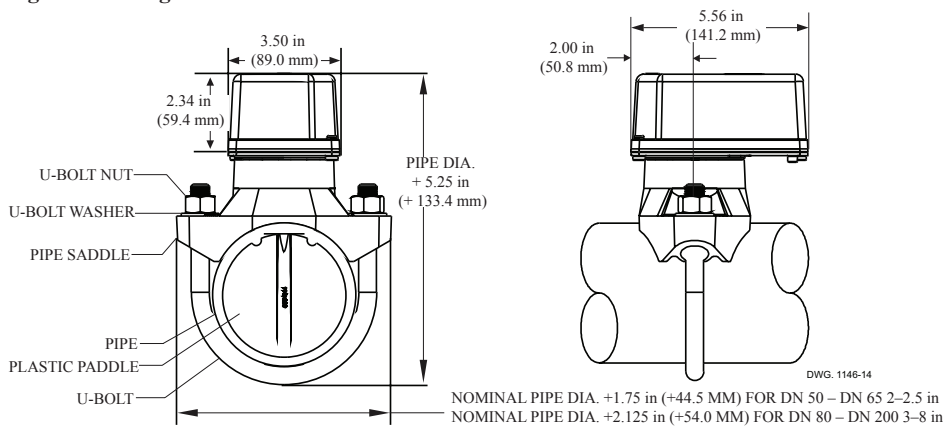
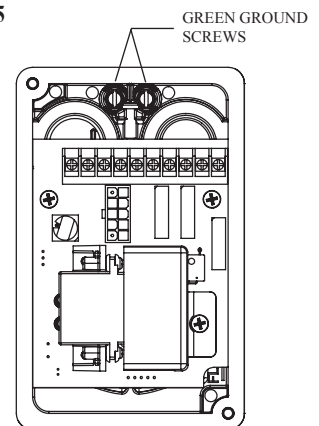

Fig. 5



Maintenance

Inspect detectors monthly. If leaks are found, replace the detector. The VSR-AT waterflow switch should provide years of trouble-free service.

Removal of Waterflow Switch

- To prevent accidental water damage, all control valves should be shut tight and the system completely drained before waterflow detectors are removed or replaced.
- Turn off electrical power to the detector, then disconnect wiring.
- Loosen nuts and remove U-bolts.
- Gently lift the saddle far enough to get your fingers under it. With your fingers, roll the vane so it will fit through the hole while continuing to lift the waterflow detector saddle.
- Lift detector clear of pipe.

Fig. 6 Typical Electrical Connections

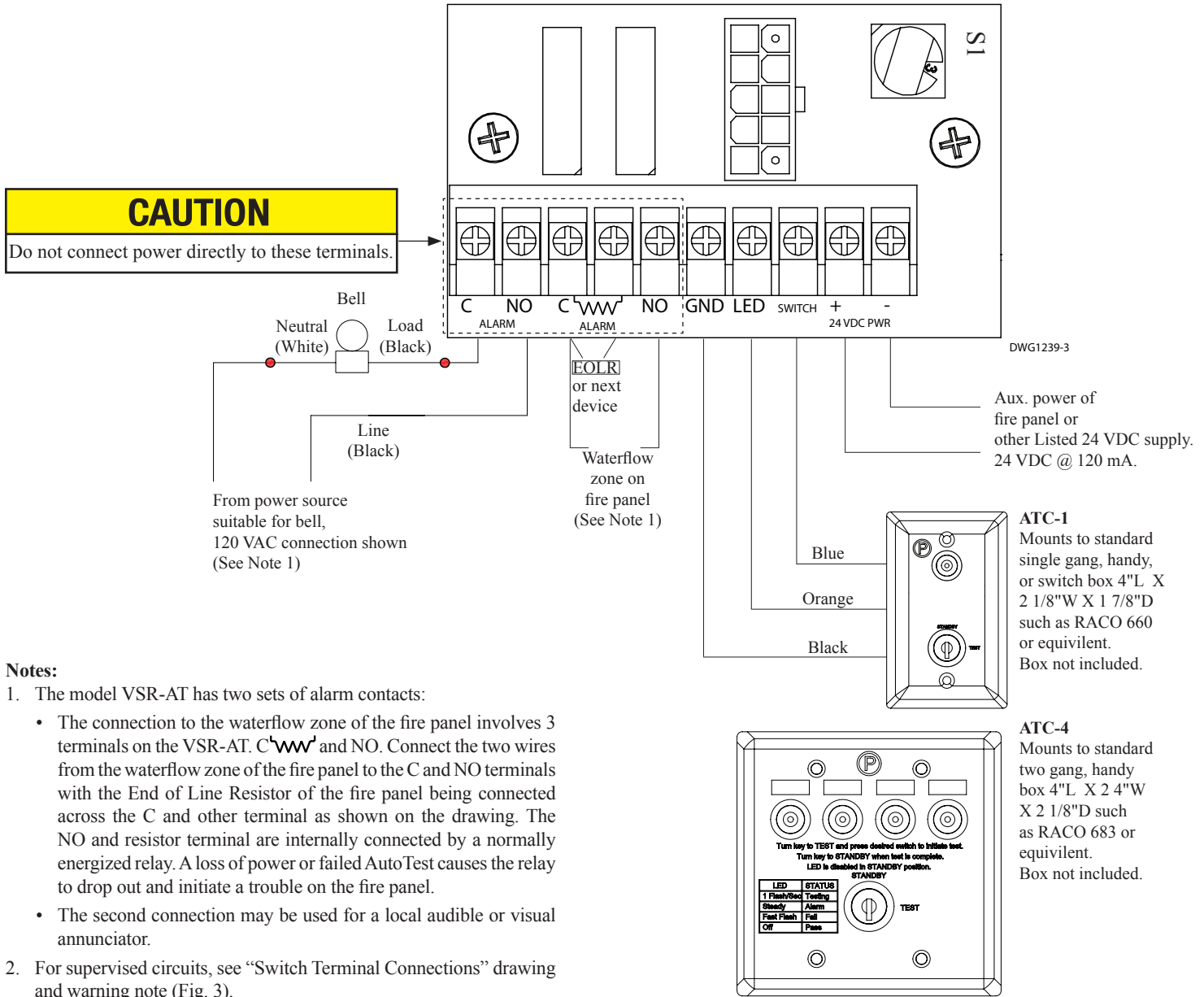

Notes:

- The model VSR-AT has two sets of alarm contacts:
 - The connection to the waterflow zone of the fire panel involves 3 terminals on the VSR-AT. C, NO and NO. Connect the two wires from the waterflow zone of the fire panel to the C and NO terminals with the End of Line Resistor of the fire panel being connected across the C and other terminal as shown on the drawing. The NO and resistor terminal are internally connected by a normally energized relay. A loss of power or failed Auto Test causes the relay to drop out and initiate a trouble on the fire panel.
 - The second connection may be used for a local audible or visual annunciator.
- For supervised circuits, see "Switch Terminal Connections" drawing and warning note (Fig. 3).

The ATC consists of a momentary push button switch, a key switch to enable/disable the push button and an LED. Turning the keyswitch to Test will enable the push button switch. Momentarily pressing the push button switch will initiate the Auto Test feature. The LED will flash once per second during the test while the retard time is being tested. After the retard time expires, the VSR-AT is put through a simulated waterflow test. If the test was successful, the LED will light for a few seconds and both sets of switch contacts on the VSR-AT will activate for a few seconds. After the LED goes out, the key switch can be returned to Standby and the fire alarm panel reset. If the test

was unsuccessful, the LED will flash 4 times per second, the switch contacts of the VSR-AT will not activate and the VSR-AT will initiate a trouble on the fire alarm panel by opening the circuit between the NO terminal and the End Of Line Resistor terminal.

Fig. 7 Typical Electrical Connections For Operation by Addressable Fire Alarm Panel

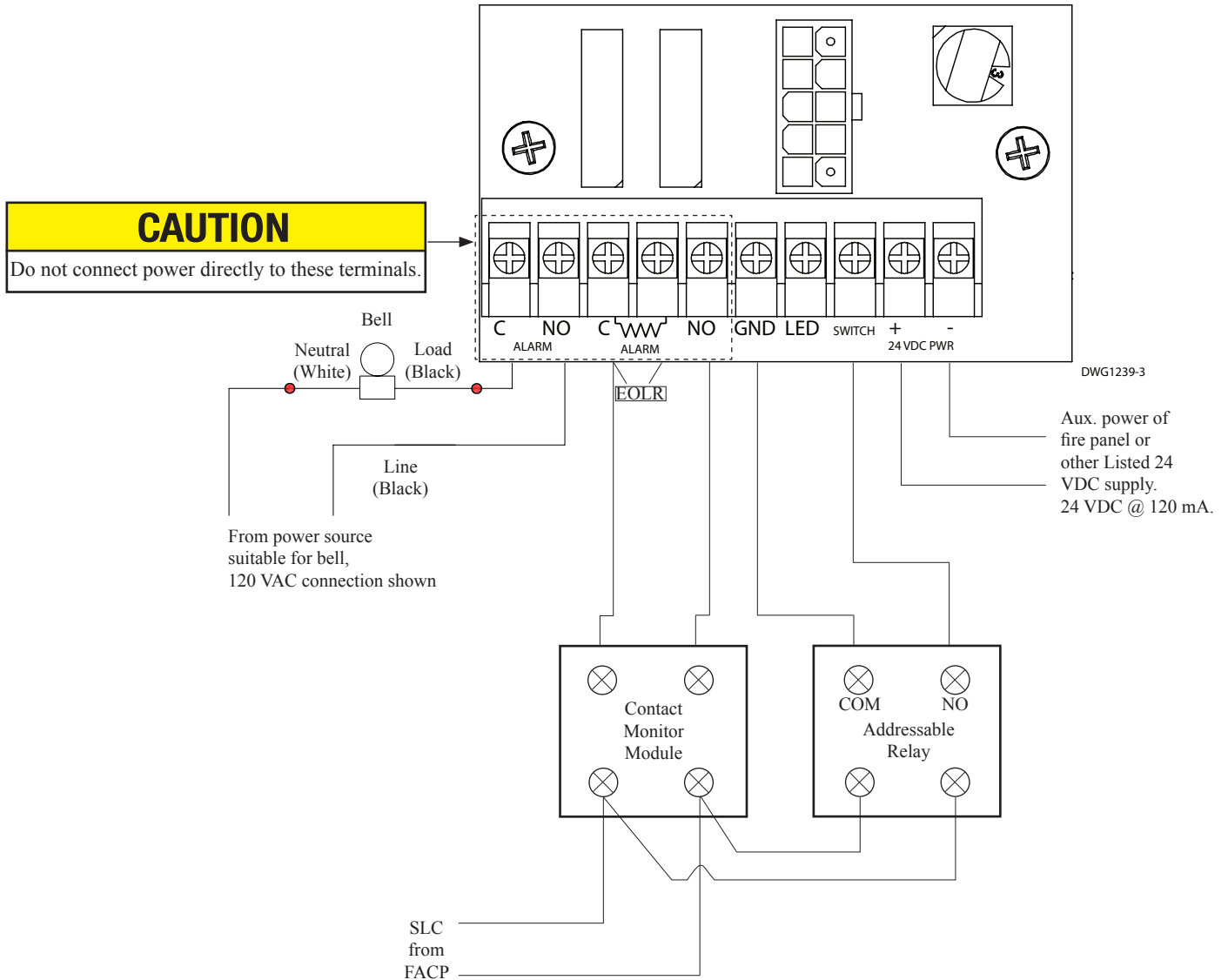

Notes:

- The model VSR-AT has two sets of alarm contacts:
 - The connection to the waterflow zone of the fire panel involves 3 terminals on the VSR-AT. C, W, W, and NO. Connect the two wires from the waterflow zone of the fire panel to the C and NO terminals with the End of Line Resistor of the fire panel being connected across the C and other terminal as shown on the drawing. The NO and resistor terminal are internally connected by a normally energized relay. A loss of power or failed Auto Test causes the relay to drop out and initiate a trouble on the fire panel.
 - The second connection may be used for a local audible or visual annunciator.
- For supervised circuits, see "Switch Terminal Connections" drawing and warning note (Fig. 3).

The Auto Test feature can be initiated by momentarily connecting the GND and Switch terminals together using the Auto Test Control (ATC) or any UL Listed switch or relay.

Trouble Shooting Guide

A successful completion of the Auto Test will momentarily activate both sets of normally open contacts on the flowswitch for approximately 2 seconds.

If the Auto Test detects a problem with the trip stem/paddle assembly, or if there is no water in the pipe, neither normally open contact will operate. The flowswitch will then indicate a trouble condition at the ATC test switch and transmit a trouble signal to the fire alarm control panel.

When Fire Panel Stays in Trouble:

- Check the wiring
- The zone of the fire panel should be wired to the VSR-AT as shown on pg. 4 of bulletin 5401239. The End of Line Resistor should be installed as shown across the terminals marked C and the terminal to the right of C which is indicated by the other end of the resistor symbol. The zone of the fire panel connects to the terminals marked C and N.O.
- The NO and End of Line Resistor terminals are connected internally by a normally energized relay. A loss of power or failed AutoTest causes the relay to drop out and initiates a trouble at the fire panel.
- The only way to clear the trouble on the fire panel is to conduct a successful AutoTest using the ATC test switch or other test method. Conducting an actual waterflow test will put the panel in alarm but will not clear the trouble.

When VSR-AT Fails the Auto Test:

- Is there water in the pipe? The VSR-ST will fail the AutoTest if the pipe it is installed on is not full of water.
- Has the return spring on the VSR-AT been adjusted? This spring has been factory set and should not be adjusted in the field. Refer to Figure 8 to determine the factory spring setting. If the spring is not at the factory setting, turn the spring adjustment screw until the factory spring setting is restored.
- For other issues contact Potter Tech Support at 866-956-1211 or visit our web site at <http://www.pottersignal.com/> run your mouse over the FIRE SPRINKELR MONITORING header and select Tools and Resources. Click on presentations to select the VSR-AT Tech brief or troubleshooting video

Fig. 8

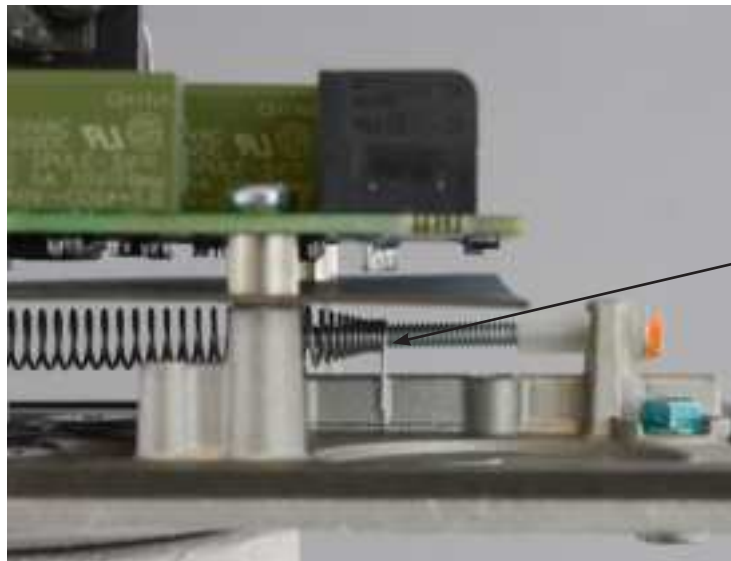

Return Spring set
to Factory Mark