

# Accessory Specifications

VB-R11

VB-M641VE / V

VB-M640VE / V

VB-M741LE/M740E

## Pendant Mounting Kit

(PC640-VB)

The exterior size, specifications, external materials, are as follows.

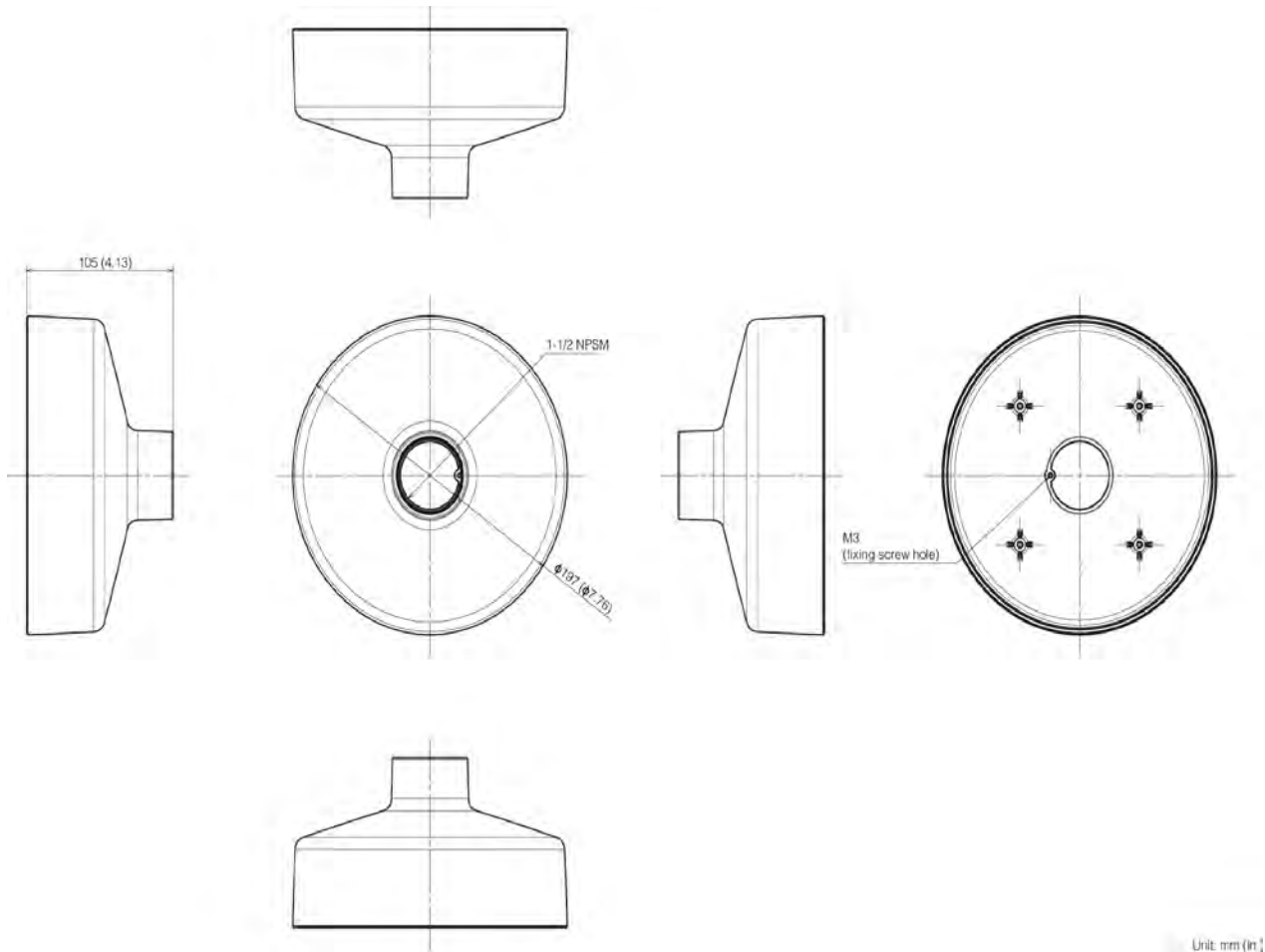

### Specification

Dimensions	( $\phi$ x H) $\phi 197 \times 105$ mm ( $\phi 7.76 \times 4.13$ in.)	
Weight	Approx. 750 g (1.66 lb.)	
Operating Environment	Temperature	Same as camera
	Humidity	Same as camera
Storage Environment	Temperature	Same as camera
	Humidity	Same as camera

### Exterior Materials

Component Name	Material Abbreviation
(1) PENDANT KIT	Die cast aluminum (ADC12)
External Color	Titanium White (paint color)