



# CDVI

Security to Access



**ievo**<sup>®</sup>  
RELIABLE. BIOMETRIC. SOLUTIONS.



## IEVO-U

**ievo® ultimate™ Fingerprint Reader  
Installation Manual**











EN

# 1] CONTENTS

---

<i><b>TITLE</b></i>	<i><b>PAGE</b></i>
2] Package Contents	3
3] Technical Features	3
4] Introduction	4
Standards	4
Help & Support	4
5] Installation Guidance	5
Power	5
Reader Head Cabling	6
Wiegand Cabling	6
Network	6
6] Control Board Connections	7
7] Door Wiring Example	8
8] Back Plate Installation	9
9] Surface Mount Installation	10
10] Flush Mount Installation	12
Installation Complete	13
11] Product Disposal	14

## 2] PACKAGE CONTENTS

					
Phoenix Connector (CTF-03008)	O-ring	Back plate screws	Security screw	Security tool	5m CAT6 cable
1	1	6	1	1	1
					
Back plate	Surface plate	Reader head			
1	1	1			







## 3] TECHNICAL FEATURES

Description	Data
CPU	ARM
Connection	Shielded (S-FTP) Cat5e/6 cable
Voltage	12V
Current Draw	600mA
Communication	RS-422 (1Mbit/s)
Controller	ievo Control Board
Operating Temperature	-20~70°C
Power Indicator	LED
IP Rating	IP65
Dimensions	Surface Mount: 128mm (H) x 93mm (W) x 93mm (D)
	Flush Mount: 153mm (H) x 119mm (W) x 47mm (D/recessed) or 45.5mm (D/visible)

## 4] INTRODUCTION

This manual will guide you through the installation of an ievo ultimate™ reader. Please ensure you read and understand all the information in this manual before commencing with installation.

### STANDARDS

Symbol	Description
	<b>Open Book</b> Please refer to the user manual once installation is complete.
	<b>Caution</b> For the safety of yourself and others please refer to the user manual for specific instructions on using this product.
	<b>Anti-Static Discharge</b> Please follow ESD safety procedures. Ground yourself to avoid any damage to the electrical components. Damage caused ESD is not covered under warranty.
<b>RoHS</b>	<b>Restriction of Hazardous Substances</b> The restriction of the use of certain hazardous substance in electrical and electronic equipment.
	<b>Waste Electrical and Electronic Equipment</b> When discarding of this product, please send to separate collection facilities for recovery and recycling. Separating from other household type waste.
	<b>European Conformity</b> Conforms with the essential requirements of the applicable European Conformity directives.
	<b>Federal Communications Commission</b> Government agency established by the Communications Act of 1934 which regulates all interstate communications.

### HELP & SUPPORT

If at any point during installation you need help, please contact the Technical Support Team:

Telephone (UK): +44 (0) 1628 531300  
 Email: [support.ievo@cdvi.co.uk](mailto:support.ievo@cdvi.co.uk)  
 Website: [www.ievoreader.com/Support](http://www.ievoreader.com/Support)

## 5] INSTALLATION GUIDANCE

---

The ultimate™ reader is IP65 rated and is suitable for both internal and external use. The reader must be continually powered on when installed outdoors to retain its IP65 rating.

The ultimate reader can be either flush or surface mounted. Ensure you use the correct fixings and plugs for the type of wall for which you are fixing the reader. Incorrect usage can result in the Ultimate reader being unsecure.

The ultimate reader should only be mounted vertically. It is not recommended to mount any ievo reader horizontally as this can affect performance and usability. We recommend that you install the Ultimate reader following DDA Guidelines, installing the reader at a height of between 1m and 1.2m. This is the optimum height for finger placement.

The ievo Control Board must be installed on the protected side of the door or turnstile. The control board is not IP rated, but can be installed inside most IP rated enclosures.

### POWER

A single ievo Control Board with two Ultimate readers connected will pull 1.6Amps when operating at full capacity. We recommend that you use a Surge Protected, 12 – 24V, AC (Alternating Current) or DC (Direct Current), 2Amp power supply unit (PSU) to power each ievo Control Board.

We also recommend fitting a backup battery.

It's important you correctly calculate the amperage rating if using a shared PSU. If using separate PSU's for separate equipment, ensure they share a common ground connection.

ievo equipment must be used with an EN 60950-1 or an equivalent IEC standard complaint PSU. This is to establish adequate safety testing of the PSU to ensure that there is enough isolation provided from the mains supply.

Please ensure that the cable used between the Power Input on the ievo Control Board and your chosen Power Supply Unit is adequate for the current, amperage and environment.

If you are using an ievo Control Board with a Power Over Ethernet (PoE) module, you will require a POE+ (802.3at) rated injector or switch to supply power and network connectivity.

***Please follow ESD Safety Procedures to prevent any damage to electronic components.***

## READER HEAD CABLING

Each ultimate reader uses a bespoke PoE (Power over Ethernet) connection to the ievo Control Board, carrying both power and data. Therefore, you must use a high-quality shielded Ethernet cable to prevent power and data loss.

Each reader comes provided with a 5m CAT6 SFTP (braid-shielded cable, foil-shielded pairs) Ethernet cable. If you need to place the reader further than 5m away from the control board, please use a cable with the following specification:

- Up to 50m – Cat5e/Cat6a SFTP Stranded-conductor, 26 AWG, with shielded RJ45 connectors
- Up to 90m – Cat5e/Cat6a SFTP Solid-conductor, 24 AWG with shielded RJ45 connectors

**Note:** Cat7 specification cable is too thick to use for connection to the head.

## WIEGAND CABLING

We recommend that you use Belden 9534 (4 Core, shielded) cable for the Wiegand connection between the ievo Control Board and Access Control Unit. We recommend twisting 2 pairs for Clock and Data and using the shielding for Ground. The distance between the ievo Control Board and Access Control Unit must not exceed 25m.

## NETWORK

Each ievo Control Board requires an Ethernet cable connected back to the local network. We recommend using CAT5e shielded cable and the distance must not exceed 90m.

If you are using the ievo Control Board with a Power Over Ethernet (PoE) module, then the cable between the PoE switch or injector and ievo Control Board must meet the below specification:

- Up to 50m – Cat5e/Cat6a SFTP Stranded-conductor, 26 AWG, with shielded RJ45 connectors
- Up to 90m – Cat5e/Cat6a SFTP Solid-conductor, 24 AWG with shielded RJ45 connectors

# 6] CONTROL BOARD CONNECTIONS

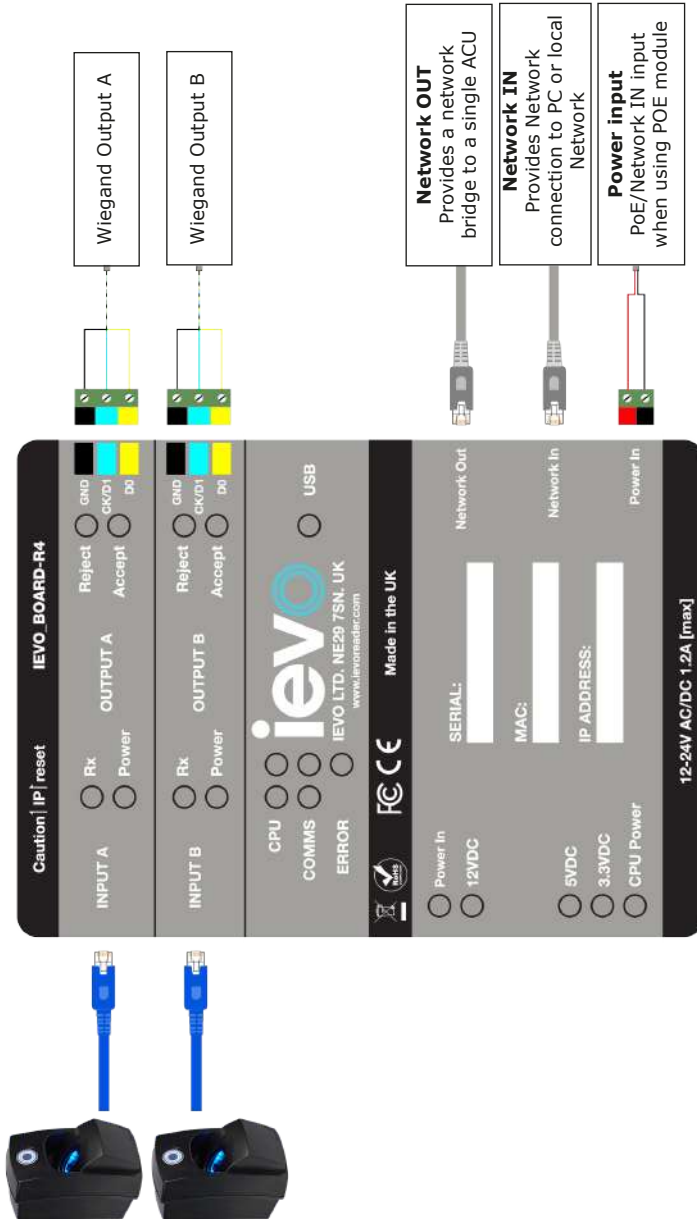

## 7] DOOR WIRING EXAMPLE

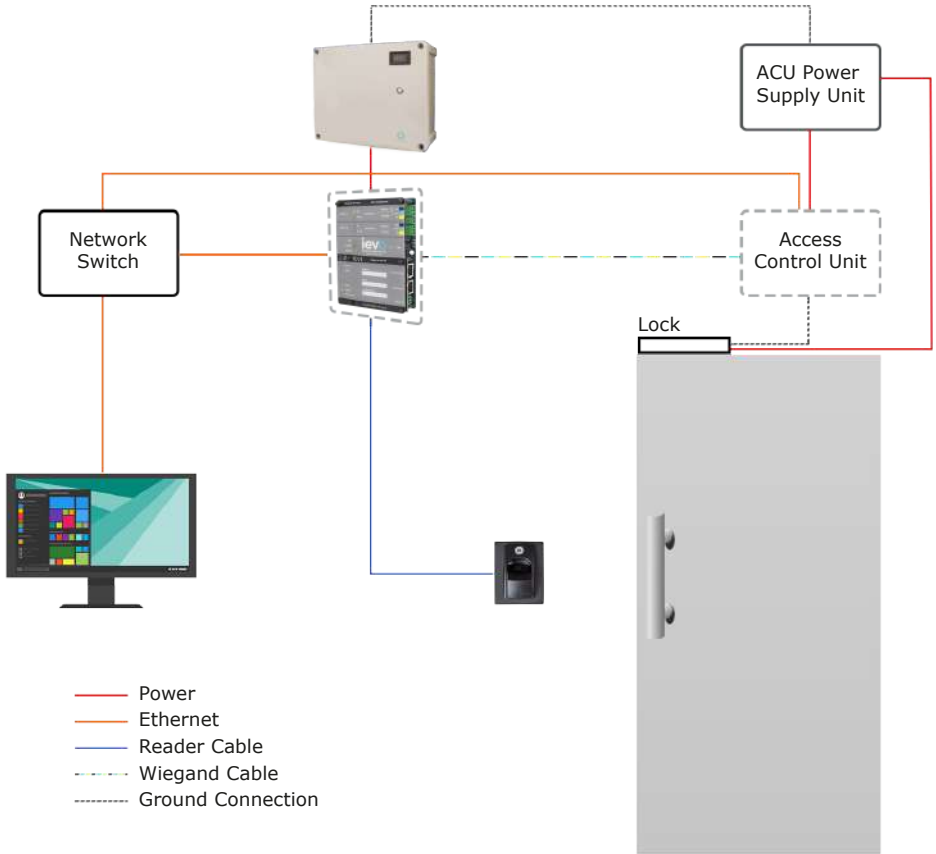



## 8] BACK PLATE INSTALLATION

The backplate is necessary to create a water tight seal and to enable the reader to be flush or surface mounted.

### STEP 1:

Plug the ethernet cable into the back of the ultimate reader. Ensure the cable is positioned into the duct as shown below.

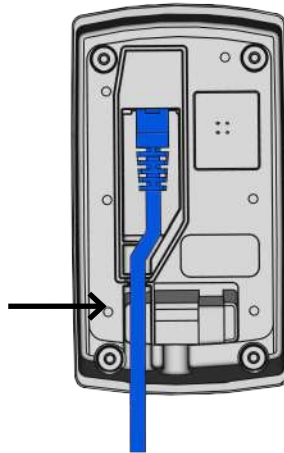

### STEP 2:

Attach the back plate to the back of the Ultimate reader using the 6 screws provided.

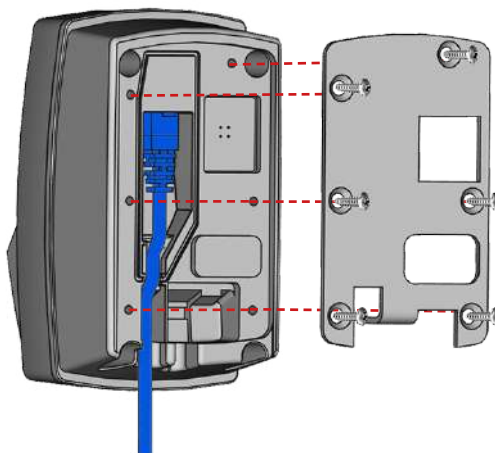

## 9] SURFACE MOUNT INSTALLATION

### STEP 1:

Use the wall plate to mark out the size of the hole required for the reader cable.

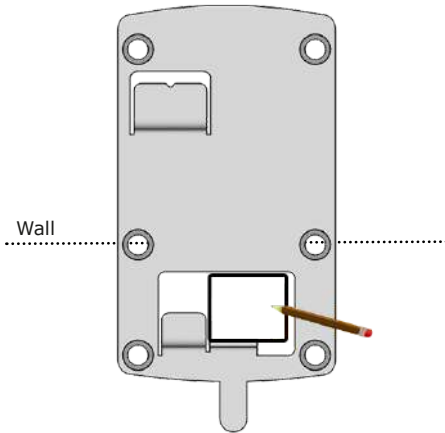

### STEP 2:

Attach the wall plate to the wall using 6 counter-sunk screws, ensuring the screw faces are flush to the wall plate.

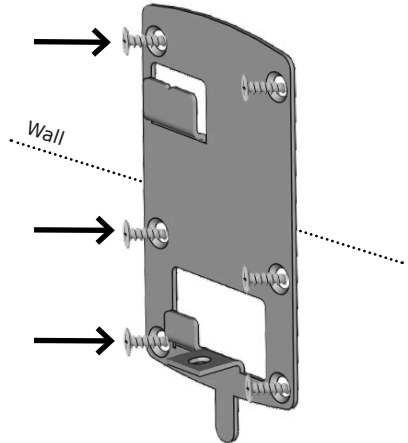

### STEP 3:

Attach the ultimate reader to the wall plate by slotting on to the plate and sliding down until locked into position. Ensure the ethernet cable is fished through the wall plate hole.

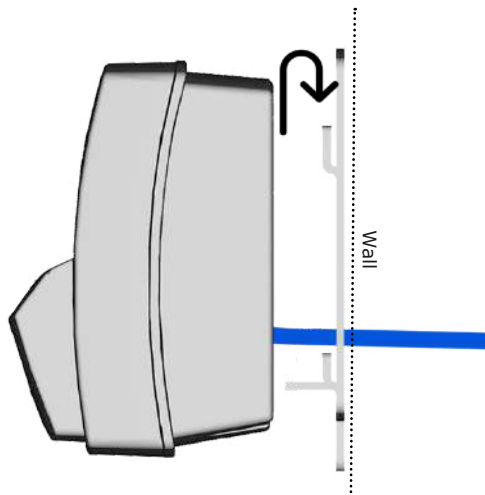

**STEP 4:**

Use the security screw and tool provided to secure both plates together.

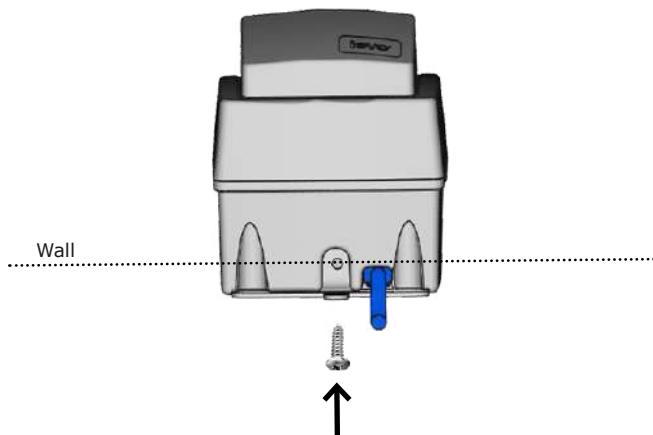
**STEP 5:**

Bend the security latch on the wall plate inwards using pliers as shown below.

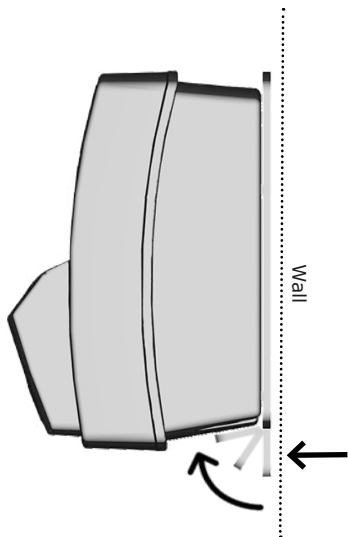
**STEP 6:**

Stretch the aesthetic seal provided over the Ultimate reader. Push to the back of the reader so that the seal covers the edges of the wall plate.

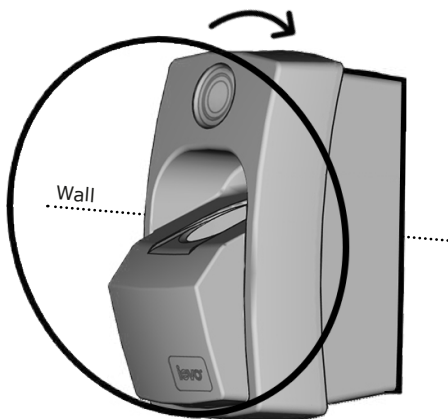

## 10] FLUSH MOUNT INSTALLATION

Ensure you have followed the instructions for attaching the Ultimate reader to the back plate before continuing (see: 8] Back Plate Installation).

### STEP 1:

Attach the wall plate to the flush mounting place using the 4 screws provided, ensuring the Ethernet cable is fed through the holes as shown below.

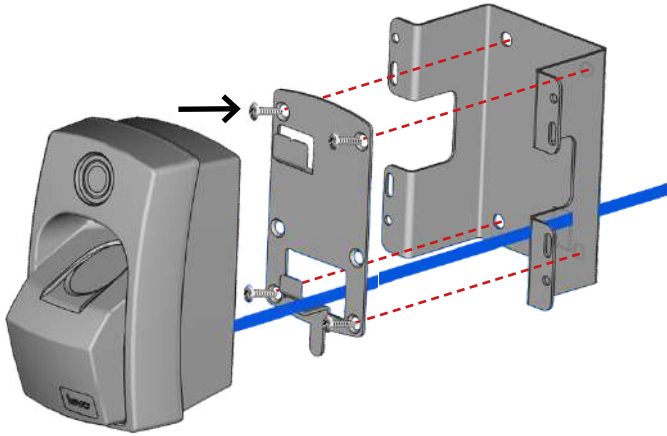

### STEP 2:

Attach the Ultimate reader to the combined wall and flush plate by slotting on to the plate and sliding down until locked into position.

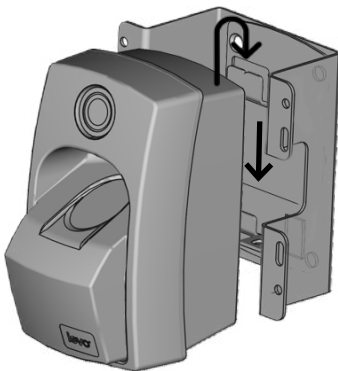

### STEP 3:

Use the security screw and tool provided to secure the wall plate and back plate together.

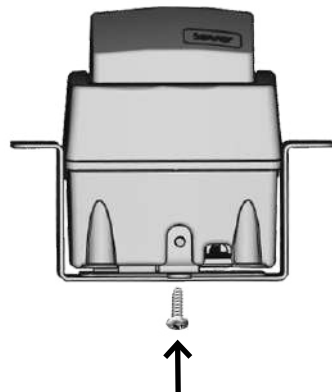

**STEP 4:**

Bend the security latch on the wall plate inwards using pliers as shown below.

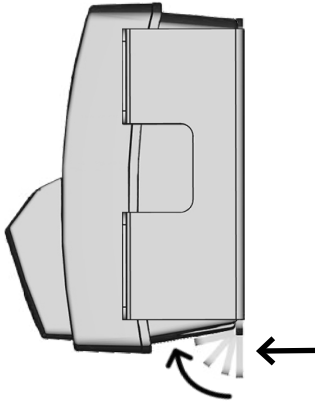
**STEP 5:**

Mount the ultimate reader and flush-kit into the wall, using the 4 security screws and security tool provided.

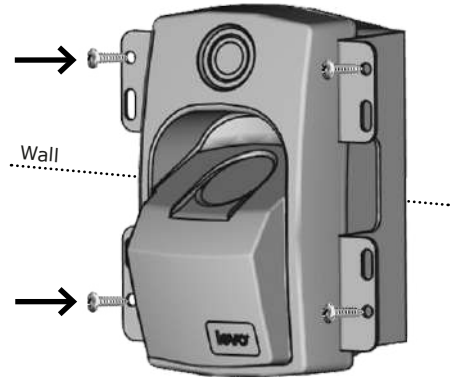
**STEP 6:**

Affix the fascia cover over the reader and click into place. Ensure the fascia is the correct way up as denoted by the arrows on the internal side.

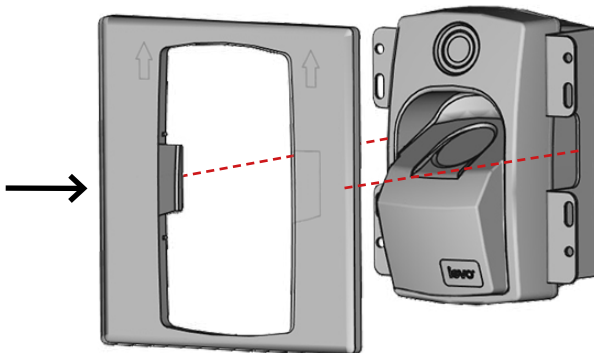
**INSTALLATION COMPLETE**

Please move onto the applicable software manual for your system. You can download all our manuals and installation guides from:

**[www.cdvi.co.uk/cat/ievo-biometric-solutions](http://www.cdvi.co.uk/cat/ievo-biometric-solutions)**

## 11] PRODUCT DISPOSAL

When the product reaches the end of its useful life, it must not be disposed of in normal waste. The product must be disposed of at an authorised recycling plant.

The ievo Control Board contains a Lithium metal primary coin cell battery (location highlighted below) and should be removed by a competent engineer prior to disposal.

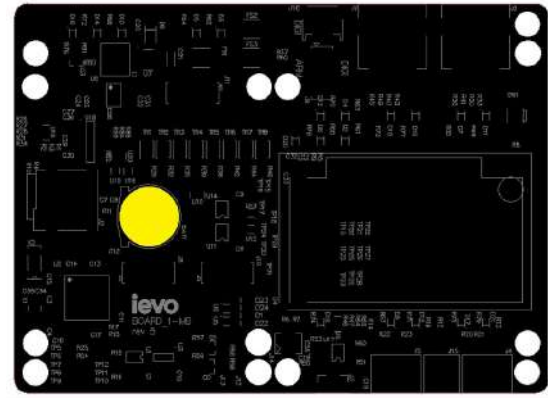
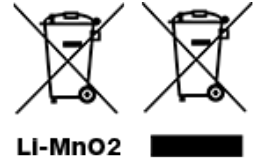

The ievo equipment and the removed battery must be disposed of separately at an authorised recycling point. Your local authority will have a centre which accepts such waste for recycling.

**WARNING:** Batteries and products containing batteries must never be disposed of in fires.



**CDVI Group**

FRANCE (Headquarters)

Phone: +33 (0) 1 48 91 01 02

.....

**CDVI FRANCE + EXPORT**

+33 (0) 1 48 91 01 02

[www.cdvi.com](http://www.cdvi.com)

**CDVI AMERICAS [CANADA - USA]**

+1 (450) 682 7945

[www.cdvi.ca](http://www.cdvi.ca)

**CDVI BENELUX [BELGIUM - NETHERLANDS - LUXEMBOURG]**

+32 (0) 56 73 93 00

[www.cdviBenelux.com](http://www.cdviBenelux.com)

**CDVI GERMANY**

+49 (0) 175 2932 901

[www.cdvi.de](http://www.cdvi.de)

**CDVI TAIWAN**

+886 (0) 42471 2188

[www.cdviChina.cn](http://www.cdviChina.cn)

**CDVI SUISSE**

+41 (0) 21 882 18 41

[www.cdvi.ch](http://www.cdvi.ch)

**CDVI CHINA**

+86 (0) 10 84606132/82

[www.cdviChina.cn](http://www.cdviChina.cn)

**CDVI IBÉRICA [SPAIN - PORTUGAL]**

+34 (0) 935 390 966

[www.cdviiberica.com](http://www.cdviiberica.com)

**CDVI ITALIA**

+39 (0) 321 90 573 - [www.cdvi.it](http://www.cdvi.it)

**CDVI MAROC**

+212 (0) 5 22 48 09 40

[www.cdvi.ma](http://www.cdvi.ma)

**CDVI NORDICS [SWEDEN - DENMARK - NORWAY - FINLAND]**

+46 (0) 31 760 19 30

[www.cdvi.se](http://www.cdvi.se)

**CDVI UK [UNITED KINGDOM - IRELAND]**

+44 (0) 1628 531300

[www.cdvi.co.uk](http://www.cdvi.co.uk)

**CDVI POLSKA**

+48 (0) 12 659 23 44

[www.cdvi.com.pl](http://www.cdvi.com.pl)

*All the information contained within this document (pictures, drawings, features, specifications and dimensions) could be perceptibly different and can be changed without prior notice.*