

# MOOG

## Videolarm

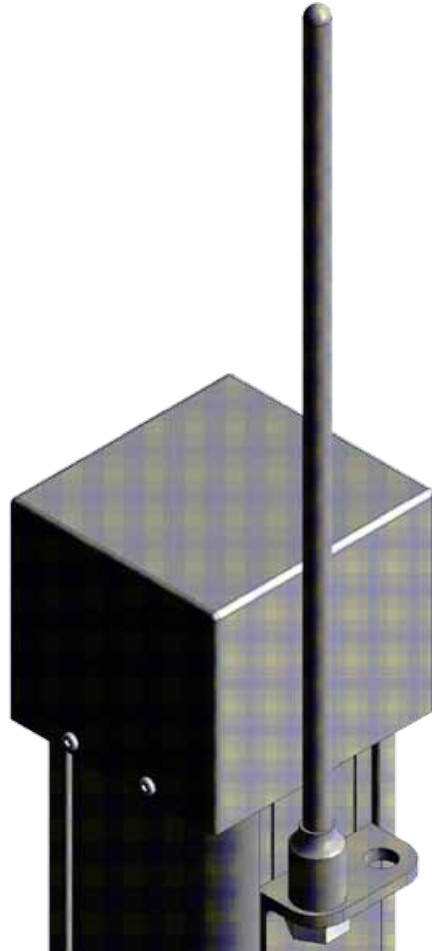

## PV1

Accessories-CCTV Poles and PoleEvator (Option)

[www.videolarm.com](http://www.videolarm.com)

Installation and Operation Instructions for the following models:

PV1      Lightning rod for free-standing poles



Before attempting to connect or operate this product,  
please read these instructions completely.

81-IN5256  
02-03-2011

## IMPORTANT SAFEGUARDS

- 1 Read these instructions.
- 2 Keep these instructions.
- 3 Heed all warnings
- 4 Follow all instructions.
- 5 Do not use this apparatus near water.
- 6 Clean only with damp cloth.
- 7 Do not block any of the ventilation openings. Install in accordance with the manufacturers instructions.
- 8 Cable Runs- All cable runs must be within permissible distance.
- 9 Mounting - This unit must be properly and securely mounted to a supporting structure capable of sustaining the weight of the unit.

### Accordingly:

- a. The installation should be made by a qualified installer.
  - b. The installation should be in compliance with local codes.
  - c. Care should be exercised to select suitable hardware to install the unit, taking into account both the composition of the mounting surface and the weight of the unit.
- 10 Do not install near any heat sources such as radiators, heat registers, stoves, or other apparatus ( including amplifiers) that produce heat.
  - 11 Do not defeat the safety purpose of the polarized or grounding-type plug. A polarized plug has two blades with one wider than the other. A grounding type plug has two blades and a third grounding prong. The wide blade or the third prong are provided for your safety. When the provided plug does not fit into your outlet, consult an electrician for replacement of the obsolete outlet.
  - 12 Protect the power cord from being walked on or pinched particularly at plugs, convenience receptacles, and the point where they exit from the apparatus.
  - 13 Only use attachment/ accessories specified by the manufacturer.
  - 14 Use only with a cart, stand, tripod, bracket, or table specified by the manufacturer, or sold with the apparatus. When a cart is used, use caution when moving the cart/ apparatus combination to avoid injury from tip-over.
  - 15 Unplug this apparatus during lightning storms or when unused for long periods of time.
  - 16 Refer all servicing to qualified service personnel. Servicing is required when the apparatus has been damaged in any way, such as power-supply cord or plug is damaged, liquid has been spilled or objects have fallen into the apparatus, the apparatus has been exposed to rain or moisture, does not operate normally, or has been dropped.

Be sure to periodically examine the unit and the supporting structure to make sure that the integrity of the installation is intact. Failure to comply with the foregoing could result in the unit separating from the support structure and falling, with resultant damages or injury to anyone or anything struck by the falling unit.

## UNPACKING

**Unpack carefully. Electronic components can be damaged if improperly handled or dropped. If an item appears to have been damaged in shipment, replace it properly in its carton and notify the shipper.**

### Be sure to save:

- 1 The shipping carton and packaging material. They are the safest material in which to make future shipments of the equipment.
- 2 These Installation and Operating Instructions.

## SERVICE

If technical support or service is needed, contact us at the following number:

TECHNICAL SUPPORT  
AVAILABLE 24 HOURS  
1 - 800 - 554 - 1124

## SAFETY PRECAUTIONS

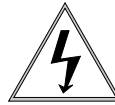
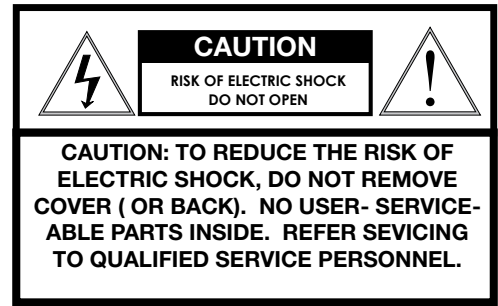

The lightning flash with an arrowhead symbol, within an equilateral triangle, is intended to alert the user to the presence of non-insulated "dangerous voltage" within the product's enclosure that may be of sufficient magnitude to constitute a risk to persons.

Este símbolo se piensa para alertar al usuario a la presencia del "voltaje peligroso no-aislado" dentro del recinto de los productos que puede ser un riesgo de choque eléctrico.

Ce symbole est prévu pour alerter l'utilisateur à la présence "de la tension dangereuse" non-isolée dans la clôture de produits qui peut être un risque de choc électrique.

Dieses Symbol soll den Benutzer zum Vorhandensein der nicht-Isolier "Gefährdungsspannung" innerhalb der Produkteinschließung alarmieren die eine Gefahr des elektrischen Schlages sein kann.

Este símbolo é pretendido alertar o usuário à presença "di tensão perigosa non-isolada" dentro do cerco dos produtos que pode ser um risco de choque elétrico.

Questo simbolo è inteso per avvertire l'utente alla presenza "di tensione pericolosa" non-isolata all'interno della recinzione dei prodotti che può essere un rischio di scossa elettrica.



The exclamation point within an equilateral triangle is intended to alert the user to presence of important operating and maintenance (servicing) instructions in the literature accompanying the appliance.

Este símbolo del punto del exclamation se piensa para alertar al usuario a la presencia de instrucciones importantes en la literatura que acompaña la aplicación.

Ce symbole de point d'exclamation est prévu pour alerter l'utilisateur à la présence des instructions importantes dans la littérature accompagnant l'appareil.

Dieses Ausruf Punktsymbol soll den Benutzer zum Vorhandensein de wichtigen Anweisungen in der Literatur alarmieren, die das Gerät begleitet.

Este símbolo do ponto do exclamation é pretendido alertar o usuário à presença de instruções importantes na literatura que acompanha o dispositivo.

Questo simbolo del punto del exclamation è inteso per avvertire l'utente alla presenza delle istruzioni importanti nella letteratura che accompagna l'apparecchio.



## LIMITED WARRANTY FOR VIDEOLARM INC. PRODUCTS

VIDEOLARM INC. warrants this Product to be free from defects in material or workmanship, as follows:

PRODUCT CATEGORY	PARTS	LABOR
All Enclosures and Electronics	Five (5) Years	Five (5) Years
Pan/Tilts	Three (3) Years **6 months if used in autoscan /tour operation	Three (3) Years **6 months if used in autoscan /tour operation
Poles/Pole Evolvers	Three (3) Years	Three (3) Years
Warrior/Q-View/I.R. Illuminators	Five (5) Years	Five (5) Years
SView Series	Five (5) Years **6 months if used in autoscan /tour operation	Five (5) Years **6 months if used in autoscan /tour operation
Controllers	Five (5) Years	Five (5) Years
Power Supplies	Five (5) Years	Five (5) Years
Accessory Brackets	Five (5) Years	Five (5) Years

During the labor warranty period, to repair the Product, Purchaser will either return the defective product, freight prepaid, or deliver it to Videolarm Inc. Decatur GA. The Product to be repaired is to be returned in either its original carton or a similar package affording an equal degree of protection with a RMA# (Return Materials Authorization number) displayed on the outer box or packing slip. To obtain a RMA# you must contact our Technical Support Team at 800.554.1124 extension 101. Videolarm will return the repaired Product freight prepaid to Purchaser. Videolarm is not obligated to provide Purchaser with a substitute unit during the warranty period or at any time. After the applicable warranty period, Purchaser must pay all labor and/or parts charges.

The limited warranty stated in these product instructions is subject to all of the following terms and conditions:

### TERMS AND CONDITIONS

**1. NOTIFICATION OF CLAIMS: WARRANTY SERVICE:** If Purchaser believes that the Product is defective in material or workmanship, then written notice with an explanation of the claim shall be given promptly by Purchaser to Videolarm but all claims for warranty service must be made within the warranty period. If after investigation Videolarm determines that the reported problem was not covered by the warranty, Purchaser shall pay Videolarm for the cost of investigating the problem at its then prevailing per incident billable rate. No repair or replacement of any Product or part thereof shall extend the warranty period as to the entire Product. The specific warranty on the repaired part only shall be in effect for a period of ninety (90) days following the repair or replacement of that part or the remaining period of the Product parts warranty, whichever is greater.

**2. EXCLUSIVE REMEDY: ACCEPTANCE:** Purchaser's exclusive remedy and Videolarm's sole obligation is to supply (or pay for) all labor necessary to repair any Product found to be defective within the warranty period and to supply, at no extra charge, new or rebuilt replacements for defective parts.

**3. EXCEPTIONS TO LIMITED WARRANTY:** Videolarm shall have no liability or obligation to Purchaser with respect to any Product requiring service during the warranty period which is subjected to any of the following: abuse, improper use: negligence, accident, lightning damage or other acts of God (i.e., hurricanes, earthquakes), modification, failure of the end-user to follow the directions outlined in the product instructions, failure of the end-user to follow the maintenance procedures recommended by the International Security Industry Organization, written in product instructions, or recommended in the service manual for the Product. Furthermore, Videolarm shall have no liability where a schedule is specified for regular replacement or maintenance or cleaning of certain parts (based on usage) and the end-user has failed to follow such schedule; attempted repair by non-qualified personnel; operation of the Product outside of the published environmental and electrical parameters, or if such Product's original identification (trademark, serial number) markings have been defaced, altered, or removed. Videolarm excludes from warranty coverage Products sold AS IS and/or WITH ALL FAULTS and excludes used Products which have not been sold by Videolarm to the Purchaser. All software and accompanying documentation furnished with, or as part of the Product is furnished "AS IS" (i.e., without any warranty of any kind), except where expressly provided otherwise in any documentation or license agreement furnished with the Product.

**4. PROOF OF PURCHASE:** The Purchaser's dated bill of sale must be retained as evidence of the date of purchase and to establish warranty eligibility.

### DISCLAIMER OF WARRANTY

EXCEPT FOR THE FOREGOING WARRANTIES, VIDEOLARM HEREBY DISCLAIMS AND EXCLUDES ALL OTHER WARRANTIES, EXPRESS OR IMPLIED, INCLUDING, BUT NOT LIMITED TO ANY AND/OR ALL IMPLIED WARRANTIES OF MERCHANTABILITY, FITNESS FOR A PARTICULAR PURPOSE AND/OR ANY WARRANTY WITH REGARD TO ANY CLAIM OF INFRINGEMENT THAT MAY BE PROVIDED IN SECTION 2-312(3) OF THE UNIFORM COMMERCIAL CODE AND/OR IN ANY OTHER COMPARABLE STATE STATUTE. VIDEOLARM HEREBY DISCLAIMS ANY REPRESENTATIONS OR WARRANTY THAT THE PRODUCT IS COMPATIBLE WITH ANY COMBINATION OF NON-VIDEOLARM PRODUCTS OR NON-VIDEOLARM RECOMMENDED PRODUCTS PURCHASER CHOOSES TO CONNECT TO PRODUCT.

### LIMITATION OF LIABILITY

THE LIABILITY OF VIDEOLARM, IF ANY, AND PURCHASER'S SOLE AND EXCLUSIVE REMEDY FOR DAMAGES FOR ANY CLAIM OF ANY KIND WHATSOEVER, REGARDLESS OF THE LEGAL THEORY AND WHETHER ARISING IN TORT OR CONTRACT, SHALL NOT BE GREATER THAN THE ACTUAL PURCHASE PRICE OF THE PRODUCT WITH RESPECT TO WHICH SUCH CLAIM IS MADE. IN NO EVENT SHALL VIDEOLARM BE LIABLE TO PURCHASER FOR ANY SPECIAL, INDIRECT, INCIDENTAL, OR CONSEQUENTIAL DAMAGES OF ANY KIND INCLUDING, BUT NOT LIMITED TO, COMPENSATION, REIMBURSEMENT OR DAMAGES ON ACCOUNT OF THE LOSS OF PRESENT



## IMPORTANT SAFEGUARDS

**CAUTION:** These instructions show only how to attach the Air Terminal and Aluminum Bonding Plate to the PolEvator™. Underwriters Laboratories has developed a stringent list of requirements for installation of lightning protection systems, which address a wide range of scenarios. Moog Videolarm recommends that you contact a firm which specializes in the installation of such systems before placing this equipment on the pole, and that the firm be allowed to complete the installation per UL requirements (Installation Requirements for Lightning Protection Systems UL96A).

**NOTE:** Attach the PV1 Lightning Rod to the PolEvator™ while on the ground. If the PV1 is being placed at an existing installation, the Polevator™ will have to be lowered to the ground before installing the Air Terminal.

**NOTE:** The products provided in this kit are UL listed, per manufacturer's certification (Harger Lightning Protection, Inc.).

## Content of Box

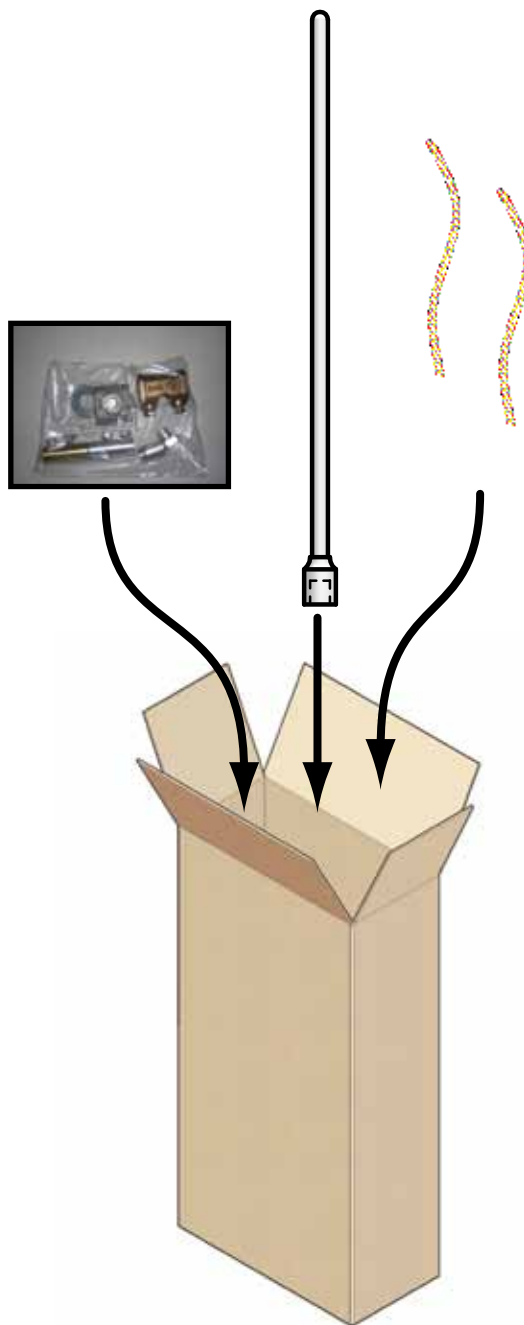

### PART

### REPLACEMENT #

**Lightning Rod**

RP70LRBT01

**Copper Cable**

RP70LRCN01

**Aluminium Cable**

RP70LRCN02

**Packet**

RP40PRPV1

1

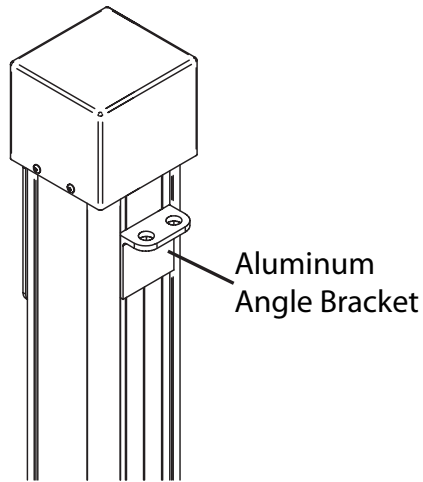

**Remove plastic coating from aluminum angle bracket. Be sure to remove all paint from bracket if needed.**

- Quite el recubrimiento plástico del corchete menor/mayor de aluminio. Está seguro de quitar toda la pintura del soporte si está necesitado.
- Enlevez le revêtement en plastique du chevron en aluminium. Soyez sûr d'enlever toute la peinture de la parenthèse si nécessaire.
- Entfernen Sie Plastiküberzug von der Aluminiumwinkelstütze. Seien Sie sicher, alle Farbe vom Haltewinkel zu entfernen, wenn Sie gebraucht werden.
- Remova o revestimento plástico do suporte de ângulo de alumínio. Seja certo remover toda a pintura do suporte se necessário.
- Rimuova il rivestimento di plastica dalla staffa di angolo di alluminio. Sia sicuro rimuovere tutta la vernice dalla staffa se avuto bisogno di.

2

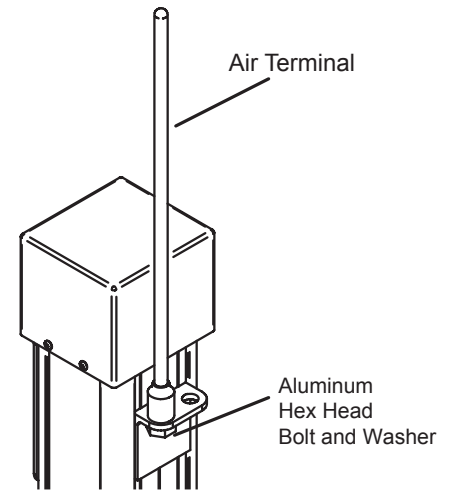

**Place the air terminal in one of the holes on the aluminum angle bracket. Attach the washer and hex head bolt and tighten securely.**

- Ponga el aeropuerto en uno de los agujeros en el corchete menor/mayor de aluminio. Ate el perno de la cabeza de la arandela y de maleficio y apriete con seguridad.
- Placez l'aérogare dans un des trous sur le chevron en aluminium. Attachez le boulon de tête de rondelle et de sortille et serrez solidement.
- Legen Sie den Air-Terminal in eins der Löcher an der Aluminiumwinkelstütze. Bringen Sie den Unterlegscheiben- und Hexekopfschraubbolzen an und ziehen Sie sicher fest.
- Coloc o terminal de ar em um dos furos no suporte de ângulo de alumínio. Una o parafuso da cabeça da arruela e de hex e aperte-o firmemente.
- Disponga l'aerostazione in uno dei fori sulla staffa di angolo di alluminio. Attacchi il bullone della testa di sfortuna e della rondella e stringa saldamente.

3

Anchor Jig Assembly

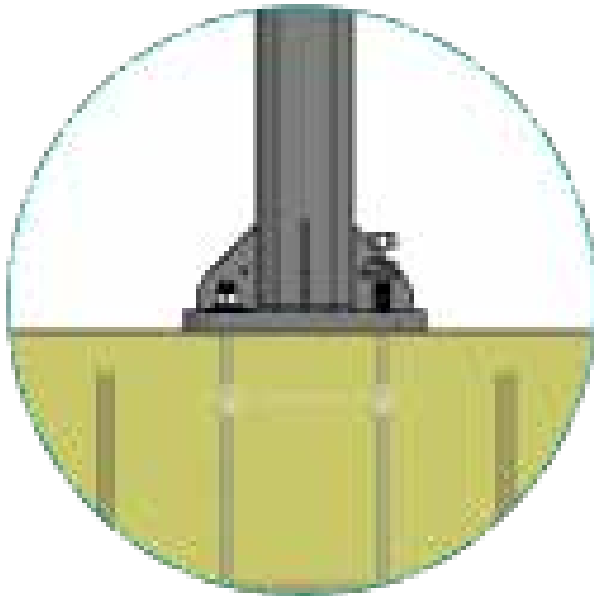

**NOTE:** The Flat Washers, Lock Washers, and remaining Hex Nuts will be used to fasten the pole to the Anchor Jig.

4



**NOTE:** The balance of this installation should be completed per UL requirements by a firm specializing in Lightning Protection System installation.

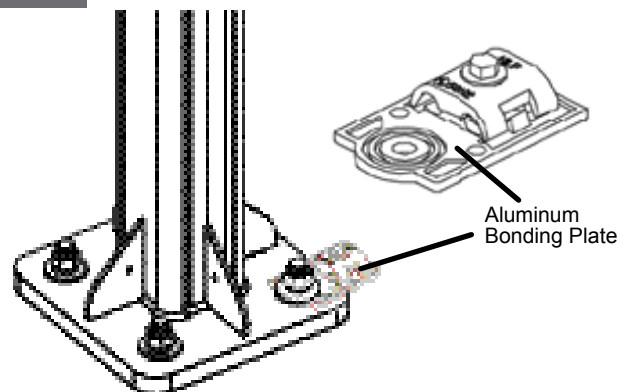

**Scrape away any paint from the area underneath the fourth bolt. Place the aluminum bonding plate over the fourth bolt and secure using washers and the fourth bolt.**

- Raspe lejos cualquier pintura del área por debajo el cuarto perno. Coloque la placa de vinculación de aluminio sobre el cuarto perno y asegúrela usando las arandelas y el cuarto perno.
- Éraflez loin n'importe quelle peinture du secteur sous le quatrième boulon. Placez la languette en aluminium au-dessus du quatrième boulon et la fixez utilisant les rondelles et le quatrième boulon.
- Reiben Sie weg jede mögliche Farbe vom Bereich unter den vierten Schraubbolzen. Setzen Sie das Aluminiummasseblech über dem vierten Schraubbolzen und sichern Sie unter Verwendung der Unterlegscheiben und des vierten Schraubbolzens.
- Raspe afastado toda a pintura da área debaixo do quarto parafuso. Coloc a placa de ligação de alumínio sobre o quarto parafuso e fixe-a usando arruelas e o quarto parafuso.
- Raschi via tutta la vernice dalla zona sotto il quarto bullone. Disponga il piatto di legame di alluminio sopra il quarto bullone e fissi per mezzo delle rondelle e del quarto bullone.

# Product Registration/Warranty

Thank you for choosing Videolarm. We value your patronage and are solely committed to providing you with only the highest quality products available with unmatched customer service levels that are second-to-none in the security industry.

Should a problem arise, rest assure that Videolarm stands behind its products by offering some of the most impressive warranty plans available: **3 Years** on all Housings, Poles, Power Supplies, and Accessories and **5 Years** on all camera systems (SView, QView, Warriors), and InfraRed Illuminators.



## Register Your Products

Option 1: **Online**      Option 2: **Mail-In**

Take a few moments and validate your purchase with our **Online Product Registration Form** at **[www.videolarm.com/productregistration.jsp](http://www.videolarm.com/productregistration.jsp)** or complete and mail-in the bottom portion of this flyer.

Register your recent Videolarm purchases and benefit from the following:

- Simple and Trouble-Free RMA process
- Added into customer database to receive product updates / news
- Eliminate the need to archive original purchase documents: Receipts, Purchase Orders, etc...



Cut at the dotted line

Place in envelope, affix stamp and mail to: Videolarm ATTN: Warranty  
2525 Park Central Ave.  
Decatur, GA 30035

## Main Contact Info

First Name: \_\_\_\_\_ Last Name: \_\_\_\_\_  
Professional Title: \_\_\_\_\_ Company: \_\_\_\_\_  
Address 1: \_\_\_\_\_ Address 2: \_\_\_\_\_  
City: \_\_\_\_\_ State / Province/Country: \_\_\_\_\_  
Zip / Postal Code: \_\_\_\_\_ Phone Number: \_\_\_\_\_ E-mail Address: \_\_\_\_\_

## Product Information

Please Circle One:

Business

Personal

Name & Location of Company / Store where Purchased: \_\_\_\_\_  
(City, State, Country)

Videolarm Product ID \_\_\_\_\_ Product Description \_\_\_\_\_

Serial # \_\_\_\_\_  
(Available only for Camera Systems, IR Illuminators, Wireless Devices)

PO# \_\_\_\_\_