

SDC Security Door Controls

801 Avenida Acaso, Camarillo, Ca. 93012 • (805) 494-0622 •
 www.sdcsecurity.com • E-mail: service@sdsecurity.com

INSTALLATION INSTRUCTIONS LR100VDK ELECTRIC LATCH RETRACTION DEVICE KIT MODELS: 3327A, 3348A, 3527A, 3548A, 9827, 9847, 9849, 9857, 9927, 9947, 9949, 9957 & 9975

Step 1

Remove Von Duprin installed mechanical dogging assembly.

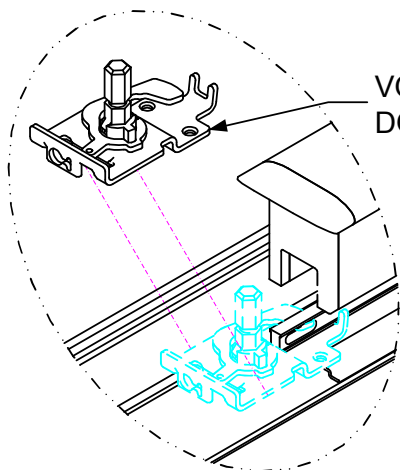

VON DUPRIN MECHANICAL DOGGING ASSEMBLY

ELECTRICAL DATA
 24VDC @ 700/200mA
 RED (+) BLK (-)
 PATENT #8,851,530

Disconnect vertical rods from the Device head

NOTE Retro-Fitting Vertical Rod Devices:

Before retro-fitting an electric latch assembly into a vertical device, the following must be done to ensure proper alignment. Disconnect the vertical rods from the device head. Install the electric latch assembly as shown above. Once the ELR is properly installed energize it so that the push pad is dogged down, by doing so it will allow for proper alignment for the vertical rods. Finally reconnect the vertical rods to the device and make the proper adjustments.

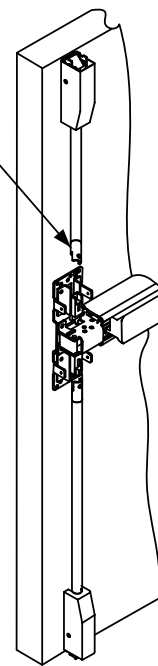

Step 2

Slide the LR100 Electric Latch Retraction assembly into device and attach the linkage to the latch retraction rod.

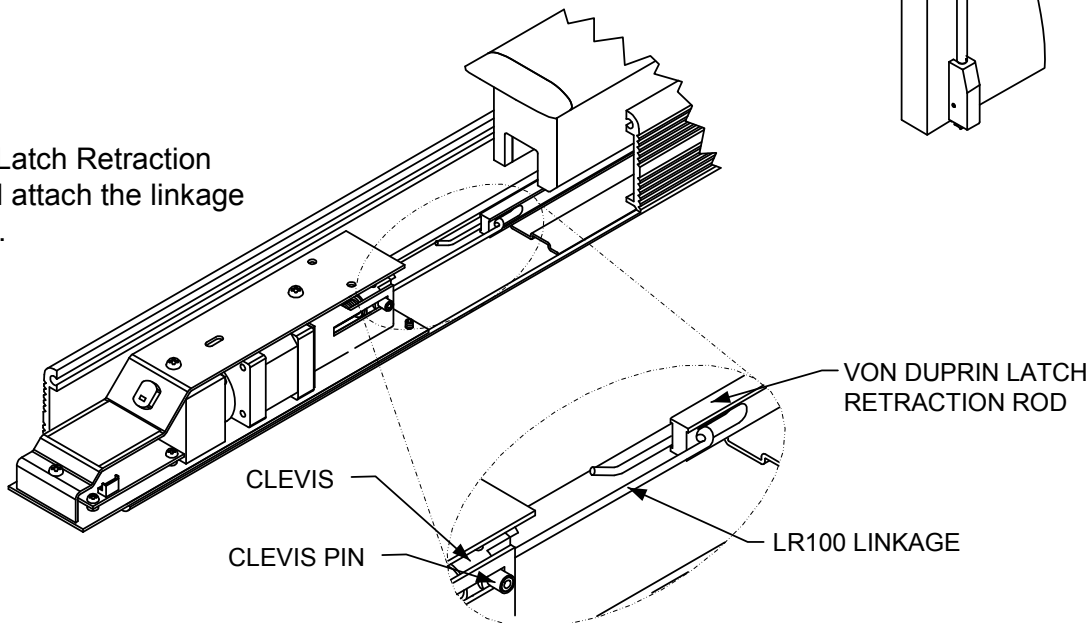

INSTRUCTIONS CONTINUED ON BACK OF PAGE

Any suggestions or comments to this instruction or product are welcome. Please contact us through our website or email engineer@sdsecurity.com

Step 3

Carefully slide the LR100 assembly back out until the linkage **JUST** makes contact with the latch retraction rod. Tighten set screws.

BACK LR100 OUT UNTIL LINKAGE JUST MAKES CONTACT HERE

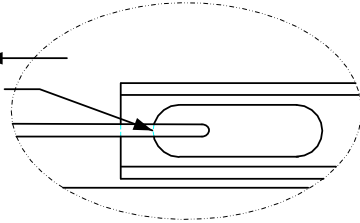

TIGHTEN SET SCREWS TO LOCK DEVICE IN POSITION

SET SCREWS

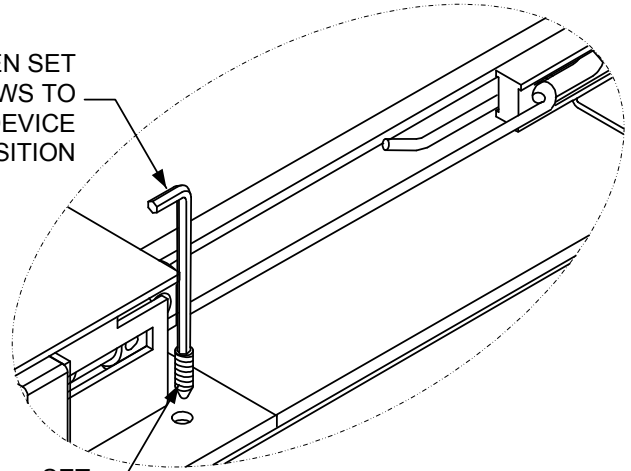

INSTALLATION INSTRUCTIONS LR-1VD CONNECTING ROD FOR USE ON VON DUPRIN DEVICES LESS DOGGING FEATURE

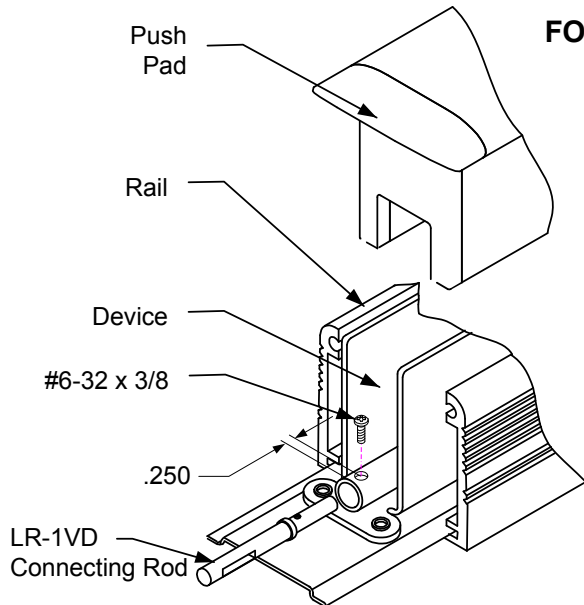

When retrofitting to existing vertical rod devices, adjustment of the rods are required for proper assembly of the LR100VDK Kit. Please see the SDC website (www.sdcsecurity.com) for installation tips and photographs of installing.

1. Remove the rail and push pad from the device
2. Drill a 5/32" (.156") diameter hole as shown in illustration.
3. Insert the connecting rod provided and fasten in screw